



AMPCO 
APPLIED PRODUCTS



SLH-4G

The Premium Hygienic Twin Screw Pump

TWIN SCREW PUMP TECHNOLOGY

A Winning Combination

Ampco Pumps
Company 

 **Bornemann**
An ITT Brand

A WINNING COMBINATION

World-renowned twin screw technology from Bornemann combined with the service, delivery and support that you have come to rely on from Ampco Pumps.

Ampco has a large inventory of pumps and parts ready to ship today!

As the first worldwide twin screw pump supplier, Bornemann introduced the hygienic SLH design of twin screw pumps in 2004 to the Food & Pharma industries. The design is based on 150 years of proven technology from Bornemann's industrial twin screw pumps. This experience aligned with the hygienic requirements of EHEDG and 3A Sanitary Standards make the SLH the world leader in sanitary twin screw pump technology. Ampco's partnership with Bornemann makes this leading technology available in the United States and beyond with full distributor support and fast deliveries.

TWO STANDARD MODELS AVAILABLE: **SLH-4G** & **SLH-4U**

Materials

- Product-contact materials: 316L / 1.4404
- Product-contact elastomers: HNBR / EPDM / FKM
- Silicon Carbide, Tungsten Carbide, and knife edge seals or other materials available on request

Connections:

- Tri-Clamp (DIN 32676)
- DIN 11851
- DIN 11864-2
- SMS 1145
- Other connections available

Features & Options

SLH-4G

- Aseptic application (EHEDG EL type Aseptic certified)
- Customized flanges
- Heating / cooling jacket on pump casing
- Wear protection options
- Higher surface finishes available
- Three part design (Cover, Pump Casing, Intermediate Flange)
- Variable port types and sizes available
- Hygienic elastomers
- Cartridge mechanical seals
- Single & double mechanical seals

SLH-4U

- Cover and pump casing have been designed as a single component
- Standard port diameter
- Hygienic elastomers
- Single & double mechanical seals

MAX VISCOSITY	MAX PSI	MAX FLOW	MAX TEMP	MAX PORT SIZE	MAX PARTICAL SIZE
1,000,000 CP	362/25 BAR	1321 GPM / 300 m ³ /hr	392°F / 200°C	6" / 152 mm	2.3" / 58 mm

316L
Stainless Body

316L
Stainless Cover

SLH-4G



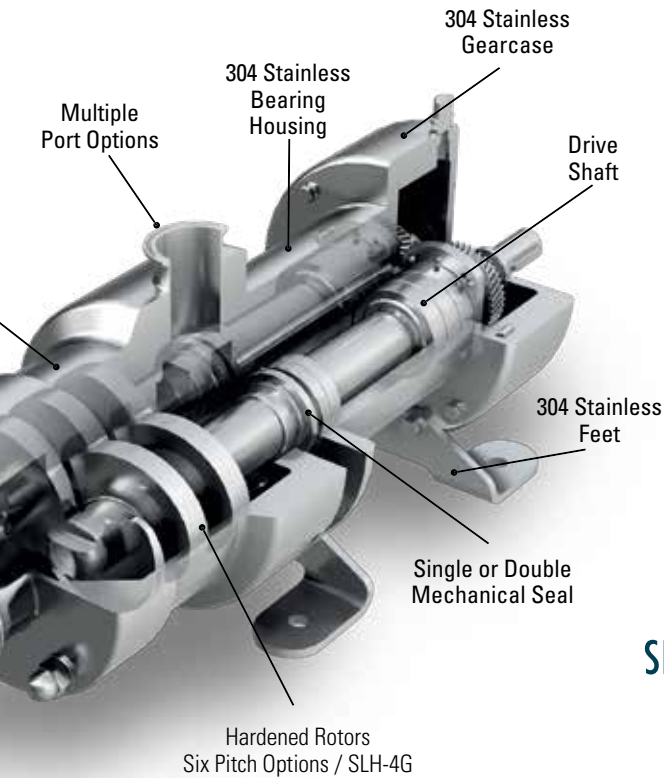

SLH-4U

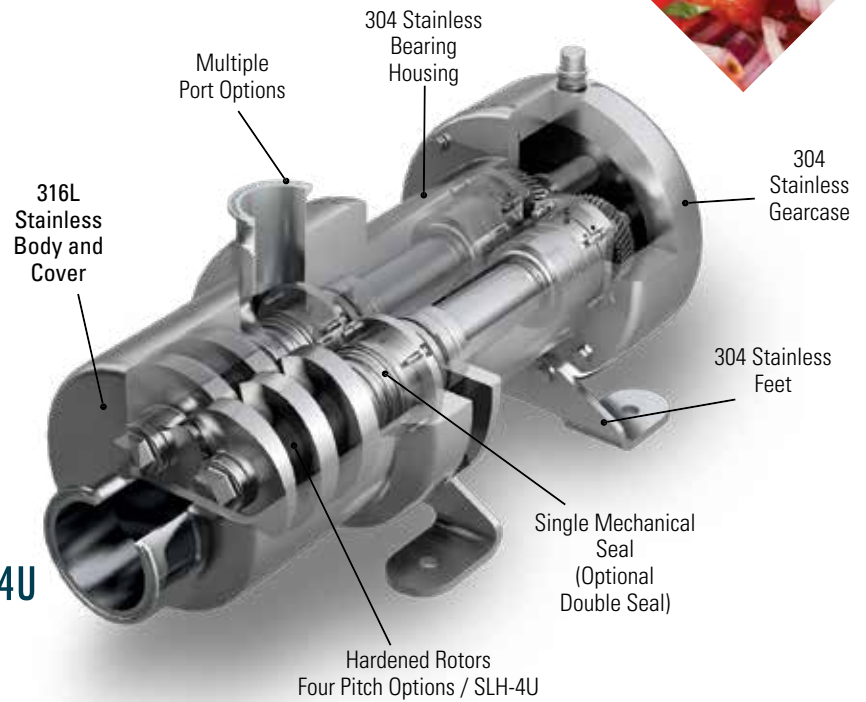

Advantages

The SLH twin screw is a dual duty pump, capable of both processing and CIP.

Product Integrity

The axial conveyance protects products maintaining size, surface and visual integrity.

Flexibility

Fifty different combinations of screw diameters and pitches ensures the best fit for your application. The pump operates at a wide range of speeds, providing flexibility for different operating points.

Long Service Life

SLH Pumps feature no metal-to-metal contact between screws and housing. This provides trouble-free conveyance even for abrasive media and minimal downtime.

Pump Characteristics

- Self-priming
- Safe operation at high viscosities
- Low pulsation
- Low noise level
- Dry running potential
- Constant flow at varying pressures and volumes
- Suction lift up to 25 feet (8.5 m)

SLH-4G

Ampco Pumps has decades of experience working with customers and understanding the food processing industry. The SLH-4G offers all the advantages of a hygienic twin-screw pump with a number of customized features and options. This provides the best solution for a wide range of applications.

The SLH-4G design features include

- Three part design (cover, pump casing, intermediate flange)
- Different flange diameters
- Hygienic elastomers
- Cartridge mechanical seals

Connections

- Tri-Clamp (DIN 32676)
- SMS 1145
- DIN 11851
- DIN 11864-2
- Other connections available

Materials

- Product-contact materials: 316L / 1.4404
- Product-contact elastomers: HNBR / EPDM / FKM
- Other materials on request

Seals

- Cartridge style
- Single and double mechanical

SLH-4G features and options

- Aseptic application (EHEDG EL type Aseptic certified)
- Customized flanges
- Heating / cooling jacket on pump casing
- Wear protection options
- Higher surface finishes available



Operating Data	Application	Unit	Size					
			1000	2000	3000	4000	5000	6000
Capacity	Medium	gpm m³/h	35 8	110 25	220 50	440 100	880 200	1321 300
	CIP		53 12	176 40	440 100	880 200	1321 300	2200 500
Differential Pressure	Medium CIP	psi bar	232 16	362 25				
Rotation Speed	Medium CIP	RPM	3600				2600	2200
Viscosity	Medium	cp cst	1,000,000					
	CIP		1					
Temperature	Medium	°F °C	392 200					
	CIP		203 95					
	SIP		302 150					

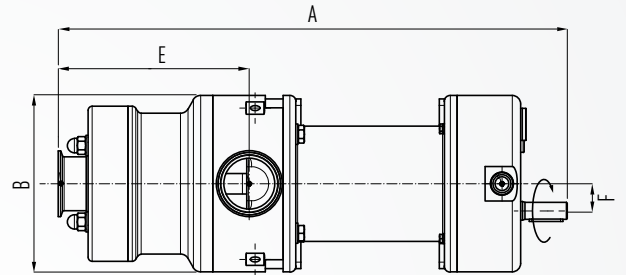
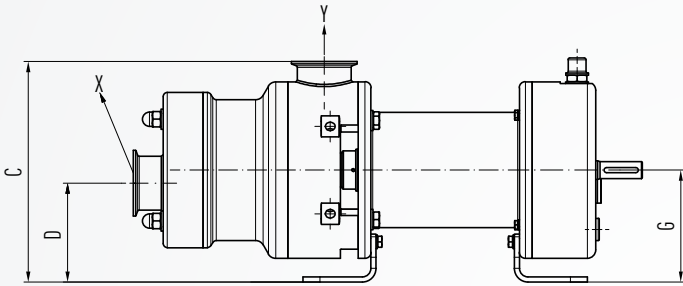

Model	A (inch / mm)	B (inch / mm)	C (inch / mm)	D (inch / mm)	E (inch / mm)	F (inch / mm)	G (inch / mm)	X	Y	Weight in lbs / kg
1000	18.50 470	7.00 178	9.06 230	4 101.5	6.89 175	4.41 112	4.41 112	DN50-DIN 11851, 2"-Tri-Clamp	DN50-DIN 11851, 2"-Tri-Clamp	88 / 40
2000	23.82 605	8.19 208	10.43 265	4.75 120	9.06 230	5.20 132	5.20 132	DN65-DIN 11851, 2.5"-Tri-Clamp	DN65-DIN 11851, 2.5"-Tri-Clamp	134 / 61
3000	27.76 705	10.16 258	12.80 325	5.56 142	10.83 275	6.30 160	6.30 160	DN80-DIN 11851, 3"-Tri-Clamp	DN80-DIN 11851, 3"-Tri-Clamp	255 / 116
4000	33.82 859	12.50 318	16.34 415	6.19 157	13.19 335	7.09 180	7.09 180	DN100-DIN 11851, 4"-Tri-Clamp	DN100-DIN 11851, 4"-Tri-Clamp	506 / 230
5000	40.28 1023	15.67 398	19.50 495	8.31 211.5	15.25 390	9.84 250	9.84 250	DN125-DIN 11851, 4"-Tri-Clamp	DN125-DIN 11851, 4"-Tri-Clamp	924 / 420
6000	45.87 1165	17.64 448	21.25 540	8.88 225	17.72 450	11.00 280	11.00 280	DN150-DIN 11851, 6"-Tri-Clamp	DN150-DIN 11851, 6"-Tri-Clamp	1540 / 700

SLH Twin Screw Pump Capacity Curves

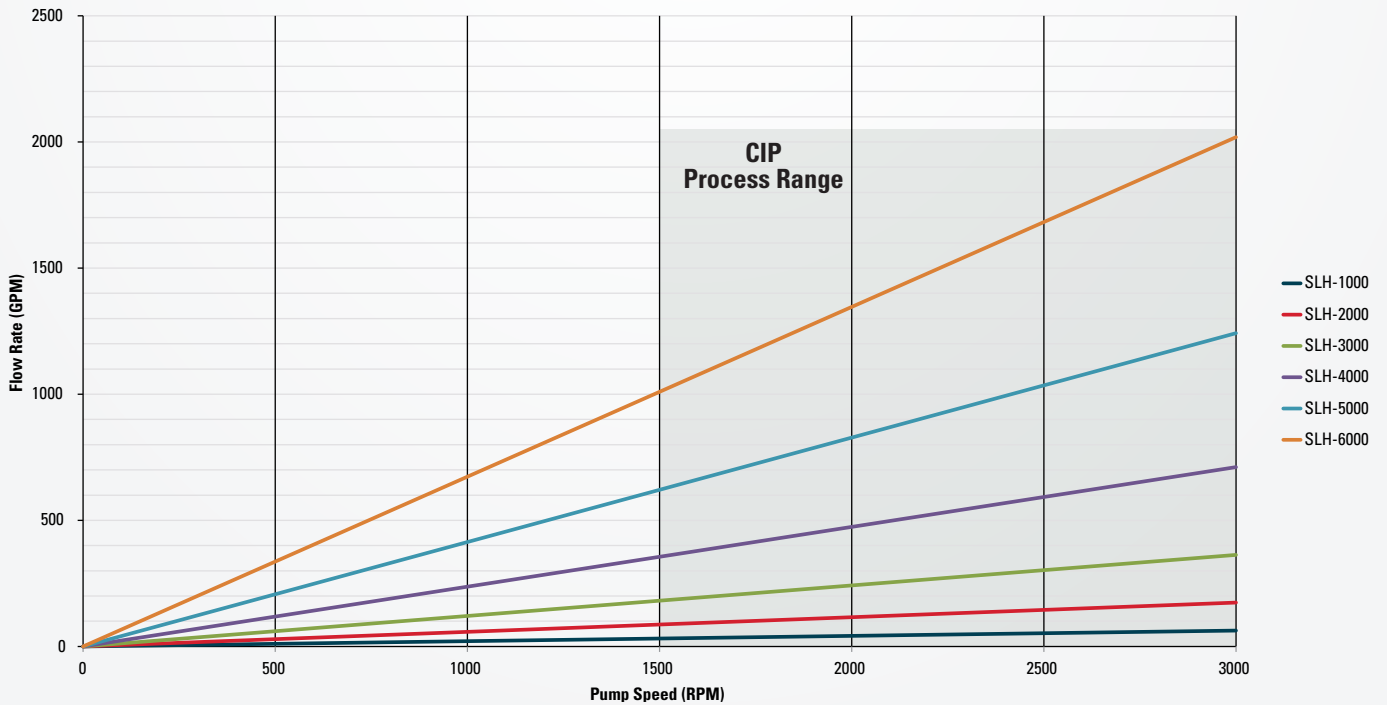

SLH-4U



Looking for a more affordable option with many of the benefits provided with twin screw pump technology? The SLH-4U was developed as a cost effective alternative to the SLH-4G. The SLH-4U is a very similar alternative to the SLH-4G with less optional features.

The SLH-4U standard features include:

- Cover and pump casing have been designed as one component
- Standard port diameters
- Hygienic elastomers
- Single mechanical seal standard (double seal available)

Connections

- The connections are integrated in the pump casing

Standard connections

- Tri-Clamp

Nominal connection sizes:

- SLH-4U 1000 – DN 50 / 2" Tri-Clamp
- SLH-4U 2000 – DN 65 / 2½" Tri-Clamp
- SLH-4U 3000 – DN 80 / 3" Tri-Clamp

Materials

- Product-contact materials: 316L / 1.4404
- Product-contact elastomers: HNBR / EPDM / FKM

Seals

- Single mechanical seal (component) (double seal available)

Operating Data	Application	Unit	Size		
			SLH-4U 1000	SLH-4U 2000	SLH-4U 3000
Capacity	Medium	gpm m ³ /h	35 8	110 25	220 50
	CIP		53 12	176 40	440 100
Differential Pressure	Medium CIP	psi bar	232 16		
Rotation Speed	Medium CIP	RPM	2500		
Viscosity	Medium	cp cst	1,000,000		
	CIP		1		
Temperature	Medium	°F °C	302 150		
	CIP		203 95		
	SIP		302 150		

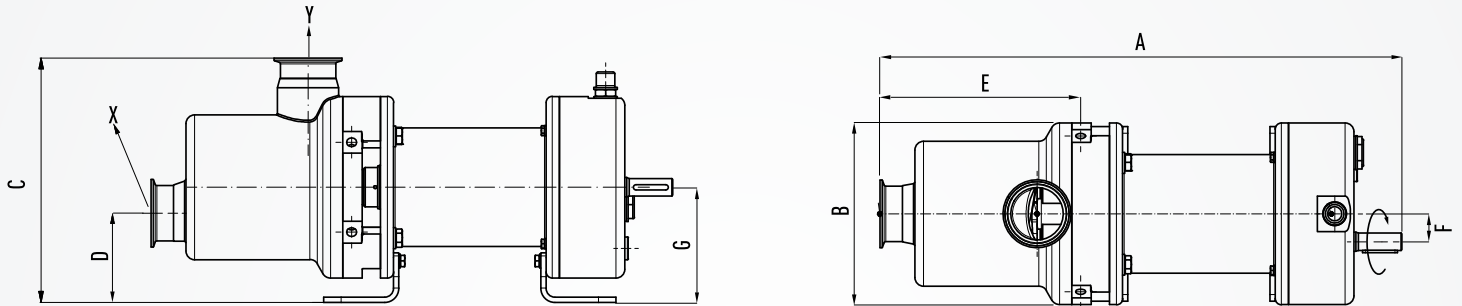

Model	Size	A (inch / mm)	B (inch / mm)	C (inch / mm)	D (inch / mm)	E (inch / mm)	F (inch / mm)	G (inch / mm)	X	Y	Weight in lbs / kg
1000	DN 50 / 2"	18.6 468	7.0 180	9.9 246	3.10 96	5.7 140	1.1 29	5.4 132	Tri-Clamp	Tri-Clamp	79.5 36
2000	DN 65 / 2½"	23.7 598	8.4 208	11.2 280	4.3 105	7.3 180	1.5 32	5.20 132	Tri-Clamp	Tri-Clamp	134.6 61
3000	DN 80 / 3"	27.6 695	10.4 258	13.8 345	4.11 125	8.5 210	1.8 41	6.5 160	Tri-Clamp	Tri-Clamp	255.9 116

SLH Twin Screw Pump Capacity Curves

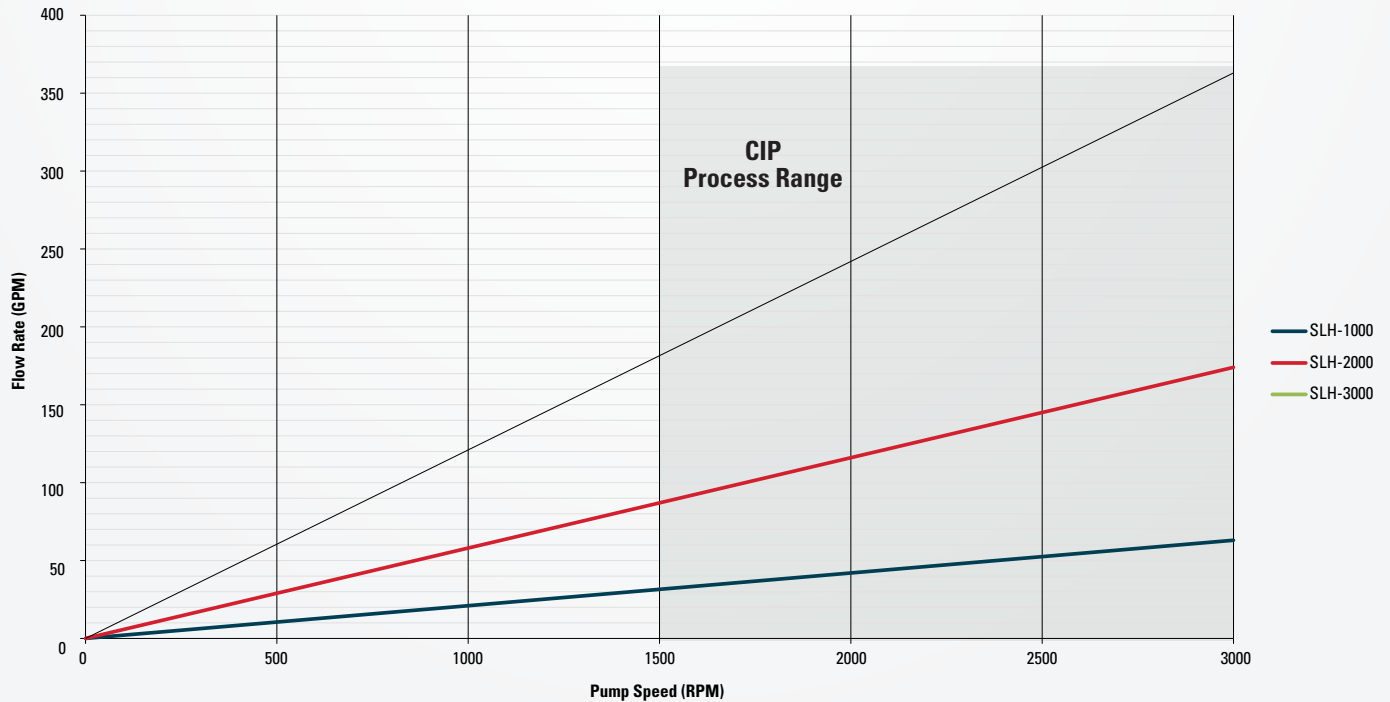



2045 W. Mill Road
Glendale, WI 53209
Phone: 800.737.8671
www.amcopumps.com

Gewerbepark West II 7
76863 Herxheim Germany
Phone: +49 7276 5058515
info@amcopumps.de

