

OPERATING INSTRUCTIONS SCREW PUMP

Only for specialist personnel!

Translation of the original operating instructions
Read the instructions prior to performing any task!

TYPE SLH-4G

01/2016 JPB 5
01/2016 RW 5

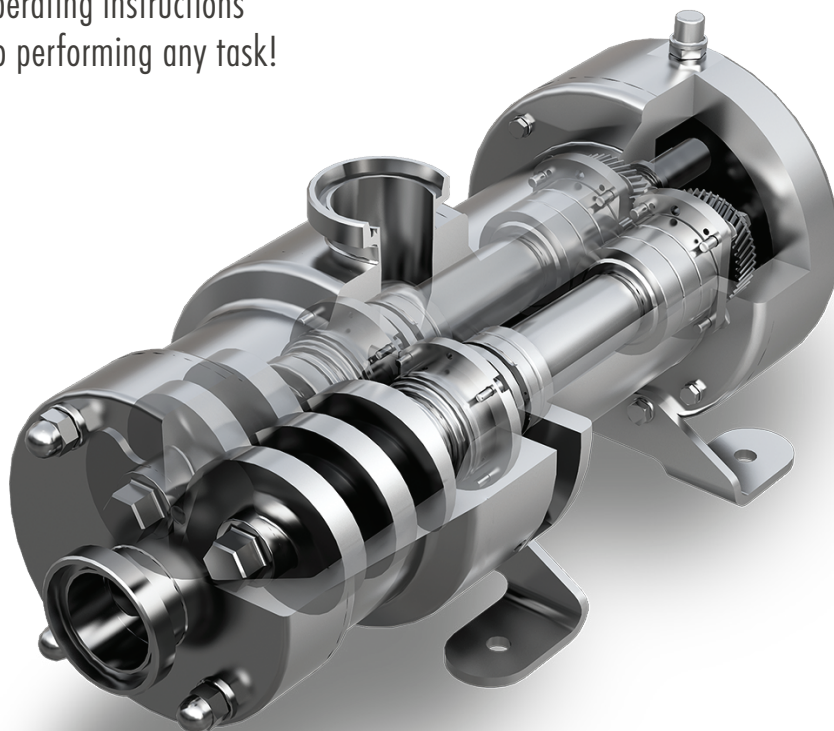

2045 W. Mill Road
Glendale, WI 53209
Phone: 800.737.8671
info@ampcopumps.com
www.ampcopumps.com

03/2020 M-042 REV A

Ampco Pumps
Company 

 **Bornemann**
— An ITT Brand

Table of contents

1	About this manual.....	6
1.1	Target groups.....	6
1.2	Additionally applicable documentation.....	6
1.3	Warning signs and symbols.....	7
1.4	Technical terms.....	8
2	Safety.....	10
2.1	Intended use.....	10
2.2	Improper use.....	10
2.3	Risk assessment.....	11
2.4	Safety instructions.....	12
2.4.1	Product safety.....	12
2.4.2	Obligations of the operator.....	13
2.4.3	Obligations of the personnel.....	14
2.4.4	Laws, guidelines and standards.....	14
2.5	Special hazards.....	14
2.5.1	Potentially explosive area.....	15
2.5.2	Hazardous pumped medium.....	15
2.5.3	Concentration of natural radioactivity.....	15
3	Structure and function.....	16
3.1	Labelling.....	16
3.1.1	Type plate.....	16
3.1.2	Type designation.....	17
3.2	Structure.....	17
3.3	Shaft seals.....	19
3.3.1	Slide ring seal.....	19
3.4	Auxiliary operating systems.....	20
3.5	CIP/SIP cleaning (Cleaning/Sterilisation in Place).....	20
4	Transport and storage.....	21
4.1	Transportation.....	21
4.1.1	Unpacking and checking the condition of contents.....	21
4.1.2	Lifting.....	21
4.2	Preservation.....	23
4.2.1	For storage periods less than 3 months.....	23
4.2.2	For storage periods longer than 3 months (maximum 3 years).....	23
4.3	Storage.....	24
4.4	Removing preservative.....	24
5	Installation and connection.....	26
5.1	Preparing the pump unit.....	26
5.1.1	Preparing the pump.....	26
5.1.2	Fitting the heat insulation (optional).....	26
5.1.3	Fitting the coupling.....	27
5.1.4	Installing the motor on base plate.....	28
5.2	Preparing for installation.....	28
5.2.1	Checking the ambient conditions.....	28
5.2.2	Preparing the installation site.....	28
5.2.3	Preparing the foundation and base.....	29
5.3	Positioning the pump unit on the foundation.....	29
5.3.1	Placing the pump unit on the foundation.....	30
5.3.2	Aligning the base plate.....	30

- 5.3.3 Securing the pump unit..... 31
- 5.4 Mounting the pump unit without foundation..... 32
- 5.5 Aligning the pump unit..... 32
 - 5.5.1 Determining alignment tolerances..... 32
 - 5.5.2 Pump alignment tolerances..... 33
 - 5.5.3 Taking into account peak height changes..... 35
 - 5.5.4 Checking the coupling alignment..... 37
 - 5.5.5 Aligning the motor..... 38
 - 5.5.6 Fitting the coupling guard..... 39
- 5.6 Planning pipes..... 39
 - 5.6.1 Configuring supports and flange connections..... 39
 - 5.6.2 Determining nominal widths..... 39
 - 5.6.3 Determining pipeline lengths..... 40
 - 5.6.4 Optimising cross sectional and direction changes..... 40
 - 5.6.5 Avoiding overpressure..... 40
 - 5.6.6 Including safety and control equipment..... 41
 - 5.6.7 Using hose lines..... 43
- 5.7 Connecting pipelines..... 43
 - 5.7.1 Avoid contamination of the pipes..... 44
 - 5.7.2 Install auxiliary pipes..... 44
 - 5.7.3 Install inlet line..... 44
 - 5.7.4 Install the outlet line..... 44
 - 5.7.5 Fitting the heating line (optional)..... 44
 - 5.7.6 Check that pipe connection is tension free..... 45
- 5.8 Electrical connection..... 45
 - 5.8.1 Earth the pump..... 45
 - 5.8.2 Connect the motor..... 45
 - 5.8.3 Checking the direction of rotation..... 46
 - 5.8.4 Connecting the instrumentation..... 46
- 6 Operation..... 47**
 - 6.1 Performing initial commissioning..... 47
 - 6.1.1 Determining the pump type..... 47
 - 6.1.2 Commissioning after shutdown..... 48
 - 6.1.3 Removing preservative..... 48
 - 6.1.4 Lubricating bearings/gears..... 48
 - 6.1.5 Preparing auxiliary operating systems (if present)..... 48
 - 6.1.6 Inertisation (for ATEX)..... 49
 - 6.1.7 Filling and bleeding..... 50
 - 6.1.8 Switching on..... 51
 - 6.1.9 Switching off..... 53
 - 6.2 Operation..... 53
 - 6.2.1 Preparing for operation..... 53
 - 6.2.2 Switching on..... 53
 - 6.2.3 Switching off..... 55
 - 6.3 Cleaning/sterilizing the pump..... 55
 - 6.3.1 CIP cleaning/sterilising at CIP temperature below 80 °C..... 56
 - 6.3.2 CIP cleaning/sterilising at CIP temperature above 80 °C and pump with sealing system or quench system..... 56
 - 6.3.3 CIP cleaning/sterilising at CIP temperature above 80 °C and pump without sealing system, without quench system..... 56
 - 6.3.4 Mechanically cleaning/sterilising..... 57
 - 6.4 Putting out of operation..... 58

6.4.1	Measures in accordance with the conveyed medium.....	58
6.5	Recommissioning.....	58
6.6	Operating the stand-by pump.....	59
6.7	Disposal.....	59
7	Maintenance and repairs.....	60
7.1	Wearing parts.....	60
7.2	Monitoring.....	60
7.3	Maintaining.....	61
7.3.1	Maintenance table.....	63
7.3.2	Lubrication.....	64
7.4	Remove pump and send to manufacturer.....	65
7.4.1	Remove pump.....	66
7.4.2	Return pump to the manufacturer.....	67
7.5	Repair pump.....	67
7.5.1	Order spare parts.....	68
7.6	Lubrication points.....	68
7.7	Lubricant.....	69
7.7.1	Gear oil, temperature of the medium to be pumped 10 – 300 °C..	69
7.8	Lubricant amounts.....	69
7.9	Preservative agents.....	70
7.10	Cleaning fluid.....	70
8	Fault finding.....	71
9	Appendix.....	73
9.1	Technical data.....	73
9.1.1	Ambient conditions.....	73
9.1.2	Noise level.....	73
9.2	Declaration of no objection.....	74
9.3	Declaration in accordance with the EC machinery directive.....	75
9.3.1	Declaration of conformity in accordance with the EC machinery directive.....	75
9.3.2	Declaration of incorporation in accordance with the EC machi- nery directive.....	76

1 About this manual

This manual:

- Is part of the pump;
- is applicable to the specified SLH-4G and SLHS-4G series.

1.1 Target groups

Target groups and their tasks

Target group	Definition	Task
Operator	<ul style="list-style-type: none"> ■ The operator is any individual who uses the pump or under whose direction the pump is used. 	<ul style="list-style-type: none"> ■ Keep this manual available at the site of operation, also for subsequent use. ■ Ensure that personnel read and observe these instructions and all supplied documents, in particular the safety and warning information. ■ Observe additional system-specific instructions and specifications.
Specialist personnel	<p>The authorised specialist personnel must:</p> <ul style="list-style-type: none"> ■ have several years of experience in the field or vocational training in the repair, maintenance and inspection of pumps; ■ be familiar with commissioning, operation and maintenance of the ITT Bornemann GmbH pumps; ■ be qualified, trained or instructed; ■ be aware of all relevant regulations and standards; ■ have specialist electrical engineering knowledge. 	<ul style="list-style-type: none"> ■ read, observe and adhere to this manual and the additional documents supplied, in particular the safety and warning information.

1.2 Additionally applicable documentation

Additionally applicable documents and their purpose



Document	Description
System documentation ¹⁾	Technical documentation for pump unit or system
ATEX additional instructions ¹⁾	Operation in potentially explosive areas
Spare parts lists ¹⁾	Sectioned drawings, parts numbers, component designation
Declaration of conformity	Conformity to standards, contents of the declaration of conformity (☞ Chapter 9.3 'Declaration in accordance with the EC machinery directive' on page 75)
Dimensional drawings	Dimensions, weight, connections
Pump datasheet	Technical data, operating conditions, output and operating limits
Supplier documentation ¹⁾	Technical documentation for supplier's parts

¹⁾ Only included in the scope of supply if the pump has been ordered correspondingly. Can be ordered subsequently, if required.

1.3 Warning signs and symbols

Warning information

Warning information given in this manual is designated by the use of symbols. The warning information is initiated by signal words which indicate the extent of the risk.

Warning information	Danger level	Consequences in the event of non-compliance
 DANGER	Directly impending danger	Death, serious injuries
 WARNING	Possible impending danger	Death, serious injuries
 CAUTION	Possible hazardous situation	Minor injuries
! NOTE	Possible hazardous situation	Property damage

Warning information in the instructions

Warning information may relate to specific, individual instructions. Such warning information is embedded in the corresponding instruction, in order to improve readability while carrying out the task. The signal words described above are used.

Example:

1.  Loosen screw.





2.  

Close the cover carefully.

3.  Tighten screw.

Special warning information

The following symbols are used within the warning information in order to make you aware of special risks:

Warning signs	Type of danger
	Warning – high-voltage.
	Warning – explosive atmosphere.
	Warning – explosive substances.
	Warning – suspended load.
	Warning – radioactive substances or ionising radiation.

Warning signs	Type of danger
	Warning – danger zone.





Tips and recommendations



This symbol highlights useful tips and recommendations as well as information for ensuring efficient and trouble-free operation.

Additional designation

The following designations are used in the manual to highlight instructions, results, lists, references and other elements:

Labelling	Explanation
	Step-by-step action instructions
	Results of carrying out actions
	Reference to sections of the manual and additionally applicable documentation
	Listing without a defined order

1.4 Technical terms

Technical terms and their meanings

Term	Meaning
API Plan	Design of the sealing system in accordance with American Petrol Institute (API).
CIP	Cleaning in Place.
Liquid slugs	Sudden fluctuations of gaseous mixture to pure liquid, or vice versa.
Auxiliary operating system	Equipment for pump operation.
Inert gas	A gas which is chemically extremely sluggish in reaction and displaces oxygen.
Render inert	Addition of inert gas (e.g. nitrogen) in order to displace explosive gases.
Cavitation	Development and abrupt dispersion of vapour bubbles in the pumped medium with a local undercutting of the vapour pressure.
Contamination	Poisoning or contamination with harmful substances.
Cooling medium	Medium used for flushing pumps, sealing chamber and sliding surfaces.
Pump unit	Pump with drive and base plate.
Pump system	Generic term for pump system and pump unit.
Pump system	Pump with drive, base plate and controller.
Quenching	Sealing system in which the pressure of the quench medium is lower than the pressure of the pumped medium. The seal is lubricated by the pumped medium. The quench medium absorbs pumped medium.

Term	Meaning
Quench medium	Medium used for quenching mechanical seals or shaft seals.
SIP	Sterilisation In Place.
Sealing	Sealing system in which the pressure of the barrier fluid is higher than the pressure of the pumped medium. The seal is lubricated by the barrier fluid. The pumped medium absorbs barrier fluid. The pumped medium has no contact with the atmosphere.
Barrier fluid	Medium used for sealing the mechanical seals.
Flushing medium	Medium used for flushing pumps, sealing chamber and sliding surfaces.

2 Safety



DANGER!

Mortal danger in the event of non-compliance with the documentation!

- Observe all of the documentation relating to the pump and all system components.
- Reading and observing the documentation is a prerequisite for proper use of the product.

2.1 Intended use

- Use system exclusively for pumping the agreed pumped medium (☞ pump data sheet).
- Adhere to operating limits (☞ pump data sheet).
- Avoid dry running:
 - Ensure that the pump is only put into operation with pumped medium and is not operated without pumped medium (☞ Chapter 6.1.7 'Filling and bleeding' on page 50).
- Avoid cavitation:
 - Open the inlet side valve fully during pump operation and do not use for regulating the pump capacity.
 - Open the outlet side valve fully during pump operation.
- Never operate the pump against a closed or partially closed valve in the outlet line.
- Avoid motor damage:
 - Observe permissible number of motor switch-on instances per hour (☞ manufacturer's instructions).
- Only use the pump if it is in a technically optimal condition and ensure it is operated in accordance with the regulations and in a safety and risk-aware manner under observance of this manual.
- Any other use must be agreed with the ITT Bornemann GmbH.
- Observe the operational limits of the pump in relation to temperature, pressure, viscosity, pump capacity and speed (☞ pump data sheet).
- When pumping liquids containing solids comply with the limit values for the proportion of solids and grain size (☞ pump data sheet).
- When pumping liquids containing gas comply with the limit values for the proportion of gas (☞ pump data sheet).
- Incorporate suitable safety valves (pressure safety valves are not system safety valves).
- Do not use the pump without a pressure safety valve or similar safeguard against exceeding the differential pressure.
- Do not use the pressure safety valve for regulating the pump capacity or pressure.
- Do not operate the pump without a check valve.
- Connect the inlet and outlet lines correctly in accordance with the direction of flow (see connection labelling).
- Check the installation direction of the check valve.
- Implement and check the connection labelling for the inlet and outlet lines.

2.2 Improper use

Any use other than uses detailed under ☞ Chapter 2.1 'Intended use' on page 10 shall be considered improper and is impermissible, for example:

- The pumping of acids and other corrosive liquids without approval of ITT Bornemann GmbH,
- The pumping of pure gases,
- The operation of pipelines without approval of ITT Bornemann GmbH,
- Operation without the required safety redundancies,
- Throttling of the outlet side,
- Filling of the pump whilst hot,
- Filling during ongoing operation,
- Spraying with high-pressure jets or fire extinguishing equipment,
- Operation with the safety devices removed,
- Failure to undertake measurements and checks for early damage detection,
- Failure to observe the maintenance intervals,
- Impermissible exchange of wearing parts,
- Incorrectly executed maintenance or repair work,
- Reversal of the permissible pumping direction,
- Inappropriate use, also of auxiliary systems.

2.3 Risk assessment

Residual risks that cannot be avoided by design throughout the entire service life of the pump system may include:

- Risk of death,
- Danger of injury,
- Environmental hazards,
- Material damage to the pump,
- Material damage to further property,
- Restrictions to performance or functionality.

You can avoid existing residual risks through the practical implementation and observation of these specifications:

- The specific warning information pertaining to the pump,
- The general safety information contained within this manual,
- As well as the specific warning information contained within this manual.

The pump may pose risks to the life of personnel due to:

- Erroneous use,
- Unprofessional handling,
- Missing safety equipment,
- Defective or damaged parts,
- Operating medium vapours,
- Operating medium gases.

The pump may pose a risk of injury to personnel due to:

- Unprofessional handling,
- Transportation,
- Hot parts,
- Contact with bare hands.

The pump may pose a risk to the environment due to:

- Unprofessional handling,
- Operating substances (pumped media, lubricants, motor oil, etc.),
- Gas emissions,
- Noise emissions,
- Risk of fire.

Damage to the pump may arise due to:

- Unprofessional handling,
- Overloading,
- Overheating,
- Oil level in the synchronisation transmission being too high/low,
- Failure to adhere to operating and maintenance specifications,
- Unsuitable operating materials.

Restrictions to the performance or functionality of the pump may arise due to:

- An ambient temperature of less than $-10\text{ }^{\circ}\text{C}$ or more than $+40\text{ }^{\circ}\text{C}$,
- The dimensioning of the upstream pipe network dependent on the operating mode.

2.4 Safety instructions

2.4.1 Product safety

The pump has been constructed in accordance with the state-of-the-art and recognised safety-relevant regulations. Nevertheless, usage of the system can lead to a risk to life and limb for the user or third-parties as well as adverse effects to the pump and other tangible assets.

Always observe the following information:

- Only have pump specialists operate the pump.
- Observe information contained in the operating manual regarding transportation, storage, installation, commissioning, operation, maintenance and filling the pump.
- Install, commission, operate, fill and maintain the pump professionally.
- Only use the pump if it is in a technically optimal condition and ensure it is operated in accordance with the regulations and in a safety and risk-aware manner under observance of this manual.
- Keep this manual and all supplied documents in a complete and legible condition and store so that personnel have them available at all times.
- Information attached to the pump must be kept complete and legible at all times.
- Refrain from any mode of operation that could lead to a risk to personnel or third-parties.
- Only operate the pump if its safety equipment is operational.
- Never operate the pump against a closed or partially closed valve in the outlet line. Never throttle the outlet side!
- In the event of safety-relevant faults, immediately shut the pump down and arrange to have the fault rectified by an authorised person.
- Maintain all statutory or other safety and accident prevention regulations as well as relevant standards and guidelines applicable in the country of operation in addition to the overall documentation provided here.
- Unauthorised modifications, manipulation or changes to the pump (changes to the drive relationships, e.g. capacity and speed) are not permitted.

- Unauthorised changes to the control software, the installation of additional software on the control computer and changes to control parameters are impermissible.
- Only use original spare parts and accessories which have been approved by ITT Bornemann GmbH.
- Regular maintenance in accordance with the maintenance schedule.
- Do not change the connection and setting values! Contact ITT Bornemann GmbH if necessary.
- Personnel executing work on the system must not be under the influence of medication, alcohol or drugs.

2.4.2 Obligations of the operator



First aid equipment and fire extinguishers are not included in the scope of supply. These must be installed by the operator. Ensure that there is easy access to the system, all ventilation openings, fire extinguishers, the first aid equipment and other safety equipment at all times.

Safety awareness when working

- Only use the pump if it is in a technically optimal condition and ensure it is operated in accordance with the regulations and in a safety and risk-aware manner under observance of this manual.
- Ensure compliance with and monitoring of the following:
 - Proper use,
 - Observation of statutory or other safety and accident prevention regulations,
 - Safety regulations for the handling of hazardous substances,
 - Applicable standards and guidelines in the corresponding country of operation,
 - Regular checking of pressure containers and the electrical systems in accordance with the local regulations and directives.
- Make personal protective equipment available, such as:
 - Protective helmet, goggles, safety shoes, hearing protection,
 - Offshore: Antistatic, flame-retardant protective clothing.
- Attach and ensure first aid equipment is ready for use.
- Install fire extinguishers and ensure they are ready for use.

Personnel qualifications

- Ensure that all personnel commissioned to undertake tasks involving the pump have read and understood these instructions and all of the supplied documentation prior to commencing work, especially the safety, maintenance and repair information.
- Regulate the responsibilities, jurisdiction and supervision of the personnel.
- Ensure that all work is carried out by qualified technical staff only:
 - Installation, initial commissioning, repairs, maintenance,
 - Work on the electrical and electronic systems.

Safety equipment

- The following safety equipment is to be provided and tested for functionality:
 - For hot, cold and moving machinery: guard (supplied by the customer) to prevent contact with the pump;
 - For possible electrostatic charging: incorporate corresponding earthing;
 - If no pressure safety valve is included in the system: incorporate suitable absolute pressure limiting into the system;
 - If no pressure safety valve or rupture disc is included in the system: incorporate suitable differential pressure safeguard in the pump.

2.4.3 Obligations of the personnel

Obligations of the personnel

- Observe local safety regulations.
- Read and observe the documentation, especially the respective "Safety" chapters. Follow all safety regulations, signs and labels.
- Observe the information on the pump and keep this in a legible condition, e.g. arrows indicating the direction of rotation, labels for liquid connections.
- Guards that protect against accidental contact for hot, cold and moving machinery must not be removed during operation.
- Always wear all of the prescribed designated personal protection gear such as safety shoes with oil-resistant soles and steel toe-caps, protective goggles, hearing protection, protective helmet and flame-retardant work clothes.
- Only carry out work on the pump at a standstill.
- Only carry out work on the pump after fully relieving the pressure.
- Prior to all assembly and maintenance work, switch off the motor and safeguard against being switched on again.
- Reinstall the safety equipment in accordance with the regulations on completion of all work on the pump.
- Treat all cuts or burns which could lead to infection. Contact a doctor in the event of injury.

2.4.4 Laws, guidelines and standards



We recommend observing the German and European regulations, e.g. the German occupational safety act (BetrSichV), accident prevention regulations (UVV), VDE-regulations, fire control plan, ATEX, pressure device regulations (DGRL), use of lifting equipment in accordance with EU guidelines.

Observe your national rules, laws, guidelines, regulations and standards. These must be observed during operation. Contact your local safety representative in the event of questions.

2.5 Special hazards



DANGER!

Mortal danger due to explosion!

- If the pump is installed within a building, always switch the ventilation on prior to access.
- Smoking is prohibited in the vicinity of the system.



DANGER!

Risk of injury due to technical faults!

- The system must be operated when in a technically faultless and undamaged condition exclusively.

2.5.1 Potentially explosive area

**DANGER!****Mortal danger due to explosion!**

Observe the additional ATEX instructions!

2.5.2 Hazardous pumped medium

Please note:

- When handling hazardous pumped medium (e.g. hot, flammable, explosive, toxic, harmful to health) observe the safety regulations applicable to the handling of hazardous substances ↗ safety datasheets).
- Use personal protective equipment during all work on the pump.
- Ensure sufficient ventilation or extraction.

2.5.3 Concentration of natural radioactivity

**WARNING!****Damage to health due to naturally occurring radioactive waves!**

- Natural gas or oil fields can contain substances that are naturally radioactive.
- If the natural radioactivity of the raw materials is enriched during pumping/extraction (e.g. as a result of precipitation or by accumulation), it is not possible to rule out damage to health through the absorption/ingestion of naturally radioactive solid particles.
- Wear suitable personal protective equipment.
- Observe all of the protective measures relevant to radioactivity.

Measures:

- Use the appropriate measuring equipment in order to measure the natural radioactivity.
- Inform everyone who enters the affected area.
- Notify the responsible authority.
- Persons with skin injuries must not work in potentially contaminated areas.
- Wear a respiratory mask in the affected areas and do not enter other areas.
- Do not handle naturally radioactive substances for longer than necessary.
- Keep as far away as possible from these substances.
- Do not open contaminated plant components unless you are wearing protective clothing.
- Wash yourself thoroughly with soap and water every time you work in this area.
- Contaminated clothing and/or contaminated plant components must be properly decontaminated or disposed of.
- All components that come into contact with media must potentially be taken into consideration.
- Taking radioactive substances (e.g. filtrate) into other areas must be avoided under all circumstances.

3 Structure and function

3.1 Labelling

3.1.1 Type plate



The serial number is additionally stamped on the pump casing.

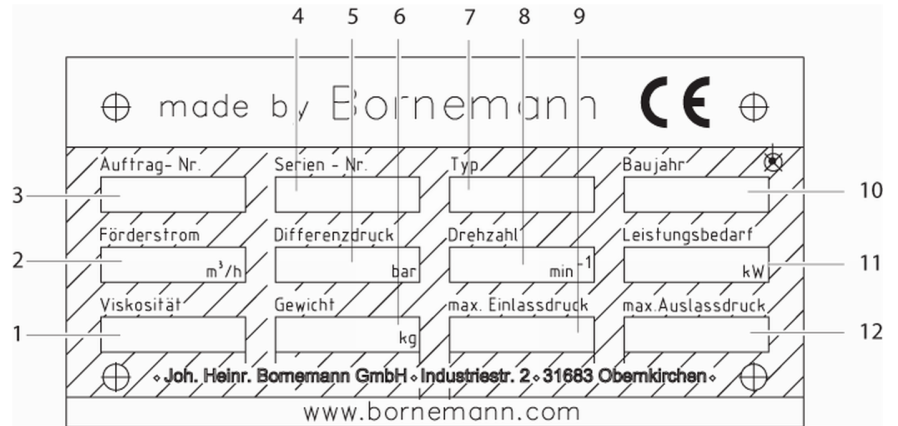

Fig. 1: Type plate (example)

No.	Description	No.	Description
1	Viscosity	7	Type
2	Pump capacity	8	Speed
3	Order number	9	Max. inlet pressure
4	Serial number	10	Year of manufacture
5	Differential pressure	11	Output demand
6	Weight	12	Max. outlet pressure

3.1.2 Type designation

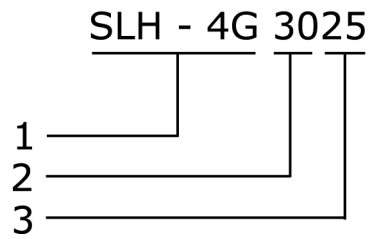

Fig. 2: Type designation (example)

No.	Description
1	Series
2	Size
3	Conveyor screw incline [mm]

3.2 Structure



The structure of the pump is shown here as an example only. The dimensional drawing is the decisive source concerning the arrangement of the inlet and outlet nozzles and the dimensions of the pump (↪ dimensional drawing).

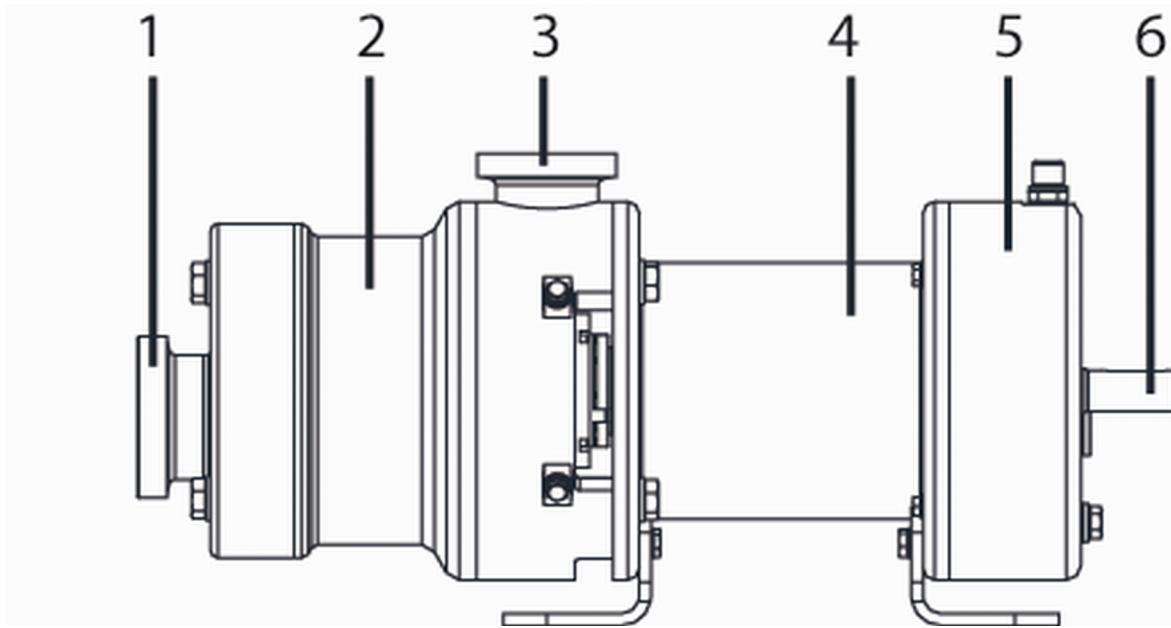

Fig. 3: Structure of the pump without base plate (example)

No.	Description	No.	Description
1	Inlet nozzle	4	Bearing casing
2	Pump casing	5	Gearing casing
3	Outlet nozzle	6	Drive shaft

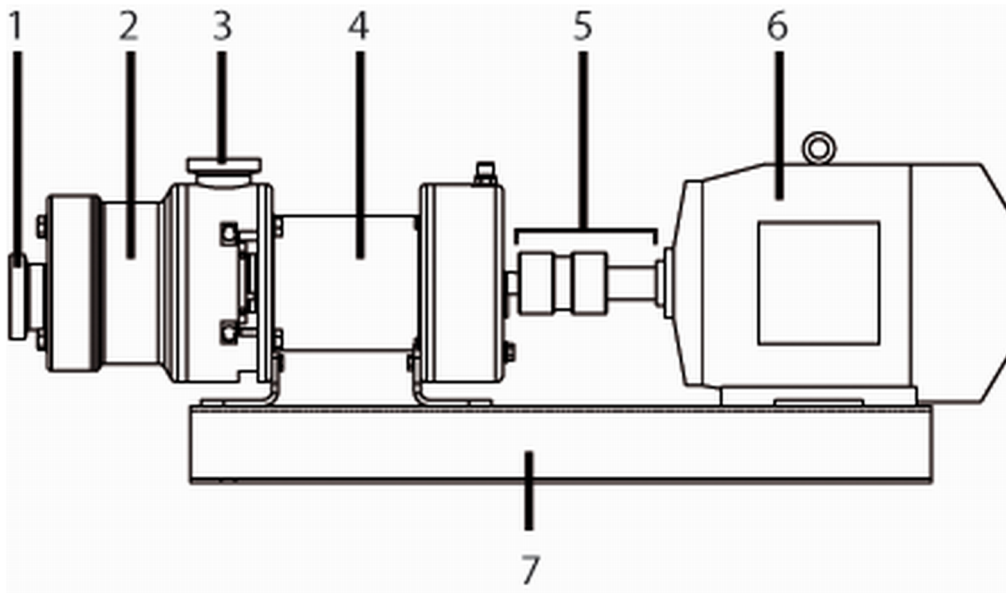

Fig. 4: Structure of the pump with base plate (example)

No.	Description	No.	Description
1	Inlet nozzle	5	Coupling
2	Pump casing	6	Motor
3	Outlet nozzle	7	Base plate
4	Bearing casing		

3.3 Shaft seals



Only one of the following shaft seals can be used.

3.3.1 Slide ring seal



Mechanical seals have function-related leakage.

- Single-action slide rings seal (☞ pump data sheet, manufacturer's documentation).
- Dual-action slide rings seal (☞ pump data sheet, manufacturer's documentation).

- Single-action slide rings seal without shaft seal (☞ pump data sheet, manufacturer's documentation).
- Single-action slide rings seal with shaft seal and pressureless storage reservoir (☞ pump data sheet, manufacturer's documentation).
- Dual-action slide rings seal and sealing system (☞ pump data sheet, manufacturer's documentation).
- Dual-action slide rings seal with quench or sealing system (☞ pump data sheet, manufacturer's documentation).

3.4 Auxiliary operating systems



For installation and function of the auxiliary operating systems, refer to ☞ manufacturer's instructions, pump datasheet, system documentation.

3.5 CIP/SIP cleaning (Cleaning/Sterilisation in Place)



SLH, SLH-S, SLH-4G and SLHS-4G series pumps:

- *Can be cleaned without dismantling.*
- *Can be used in the sterile area.*

4 Transport and storage

4.1 Transportation



Weight information ☞ dimensional drawings.

Prior to transport: Empty the pump of environmentally harmful substances and clean (☞ safety data sheet for operating materials).

Transport with base plate ☞ dimensioned drawing, general arrangement drawing, pump system operating instructions.

4.1.1 Unpacking and checking the condition of contents

1. → Unpack the pump/unit on receipt and check for externally visible signs of transport damage.
2. → Immediately report transport damage to the haulage company and ITT Bornemann GmbH.
3. → Dispose of packaging materials in accordance with locally applicable regulations.

4.1.2 Lifting



DANGER!

Death or crushing of limbs due to falling transported equipment!

- Never stand under suspended loads.
- Maintain safety distance.



NOTICE!

Property damage due to improper transportation!

- Do not lift the pump by its bearing case or gear case.
- Ensure that the pump unit is not overly tensioned when it is lifted.
- Ensure that the lifting tackle cannot damage pipelines or units when lifting, possibly use a lifting frame (☞ dimensional drawings, operating instructions for pump system).
- Make personal safety equipment available.
- Observe statutory or other safety and accident prevention regulations.



Fig. 5: Fastening the lifting tackle to the pump

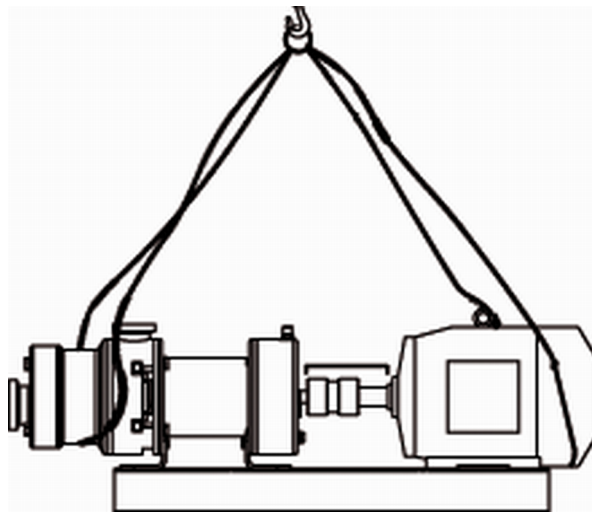

Fig. 6: Fastening the lifting tackle to the pump unit



The lifting eyelets and anchoring points for transport are labelled on the pump.

1. Select the lifting equipment in accordance with the total weight to be transported (☞ dimensional drawings).
2. Fasten the lifting equipment per the preceding figures in accordance with the markings on the pump.
3. Ensure that the lifting tackle is not overly tensioned.
4. Lift the pump/unit in a proper manner.

4.2 Preservation



All visible shaft sections, blank parts and non-corrosion-resistant metal components are preserved for shipping, unless otherwise ordered.



NOTICE!

Property damage due to improper preservation!

- Only use preservative compatible with pumping media.
- Preserve the pump properly, both internally and externally.
- Do not release the sealing flange and mechanical seals.
- Do not preserve non-metal parts.

4.2.1 For storage periods less than 3 months

1. ➤ If present, Remove plastic cover on inlet and outlet sides.
2. ➤ Lubricate all visible, internal and external uncoated metal parts with an acid-free and resin-free grease.
3. ➤ Seal off the inlet and outlet sides with plastic covers.

4.2.2 For storage periods longer than 3 months (maximum 3 years)



NOTICE!

Material damage due to incorrect storage!

- Ensure proper preservation in order to avoid corrosion damage.

1. ➤ If present, Remove plastic cover on inlet and outlet sides.
2. ➤ Lubricate all visible, internal and external uncoated metal parts with an acid-free and resin-free grease.
3. ➤ Lubricate all flange connections with an acid-free and resin-free grease.
4. ➤ Fill the internal cavities of the pump casing with preservative (☞ Chapter 7.9 'Preservative agents' on page 70).
5. ➤ Seal off the inlet and outlet sides with plastic covers (sealing plugs).
6. ➤ Protect mechanical seals against dust and damage.
7. ➤ Drain lubricating oil from the transmission housing and bearing hood, then fill with preserving oil (☞ Chapter 7.3.2 'Lubrication' on page 64).
8. ➤ Remove the ventilation filter from the transmission housing and bearing hood and seal the openings tight with a sealing plug.

9. ➔



NOTICE!

Material damage due to overly high pressure when topping up grease

- When topping up grease avoid overly high pressure.

Top up the hollow spaces of the roller bearings carefully with grease via the grease nipples, subsequently clean the respective top-up point to remove any grease leaks.

10. ➔

In the case of drive-side oil lubrication of the bearings, fill the hollow spaces of the bearings with oil.



Following storage periods exceeding 3 years: ITT Bornemann GmbH should be contacted in order to put the pump back into operation.

4.3 Storage



For storage periods longer than 3 months: Observe measures for long-term preservation (☞ Chapter 4.2.2 'For storage periods longer than 3 months (maximum 3 years)' on page 23).



NOTICE!

Property damage due to improper storage!

- Preserve and store the pump correctly.

1. ➔

Seal off all openings with blank flanges, sealing plugs or plastic covers.

2. ➔

Ensure that the storage site fulfils the following requirements:

- dry,
- frost-free,
- vibration-free.

3. ➔

Rotate the shaft once per month (approx. 30°).

4. ➔

Check the preservation status once per month. Renew the preservation agent if necessary.

4.4 Removing preservative



Only necessary for preserved pumps.



WARNING!

Damage to health resulting from cleaning agents!

- Use personal protective equipment for all work involving the use of cleaning agents.
- Do not inhale cleaning agent vapour.



NOTICE!

Property damage resulting from excessive water pressure or sprayed water!

- Do not clean the pump with a water jet or steam cleaner.



NOTICE!

Risk of damage to the seals resulting from incorrect cleaning agents!

- Ensure that the cleaning agent used will not damage the seals.

1. ➔ Remove plastic cover (sealing plug) on inlet and outlet sides.
2. ➔ Select the cleaning agent in accordance with the area of application (☞ Chapter 7.10 'Cleaning fluid' on page 70).
3. ➔ Remove the preservation agent with cleaning fluid and a cloth or operate the pump with a cleaning agent.
4. ➔ Dispose of the cleaning agent in accordance with locally applicable regulations.
5. ➔ Check all external elastomers (O-rings, shaft seals) for form elasticity and replace if necessary.
6. ➔ Following storage periods exceeding 3 months: Drain preservative oil from the transmission housing and bearing hood, then fill with lubricating oil (☞ Chapter 7.3.2 'Lubrication' on page 64).
7. ➔ Following storage periods exceeding 3 months: Remove the sealing plugs from the transmission housing and bearing hood and insert ventilation filter.
8. ➔



Due to the high degree of air humidity and temperature variations condensate collects, which is not visible beneath the oil.

In the case of drive-side oil lubrication of the bearings, fully drain oil from the hollow spaces of the bearings and replace with new oil.

5 Installation and connection

After storage times exceeding 3 months, observe measures for removing the preservative (↪ Chapter 4.4 'Removing preservative' on page 24).



Installation options:

- With steel foundation frames (↪ dimensioned drawing, pump system operating instructions)
- With a concrete foundation (please consult with ITT Bornemann GmbH)



DANGER!

Mortal danger due to explosion!

Observe the additional ATEX instructions!



WARNING!

Risk of injury due to unprofessional work!

- Only allow work to be carried out by technical specialists who have the required knowledge and practical experience to do so:
 - Installation, initial commissioning, repairs, maintenance,
 - Work on the electrical and electronic systems.
- Make personal safety equipment available.
- Observe statutory or other safety and accident prevention regulations.



NOTICE!

Property damage due to contamination!

- Only remove the covers and transport locks immediately prior to connecting the pipes with the pump.

5.1 Preparing the pump unit

5.1.1 Preparing the pump

1. ➤ If the pump is to be put into operation immediately after installation and connection: Remove preservative prior to installation (↪ Chapter 4.4 'Removing preservative' on page 24).
2. ➤ Carry out requisite measures after extended storage/standstill time (↪ Chapter 4.4 'Removing preservative' on page 24).

5.1.2 Fitting the heat insulation (optional)



For correspondingly ordered pumps only. Only needed to maintain the temperature of the conveyed medium.



NOTICE!

Material damage due to incorrect insulation!

- Install thermal insulation such that any leakage can be reliably detected.



NOTICE!

Property damage due to overheating!

- Fit thermal insulation only to the pump housing.

- Install the heat insulation properly (only in area A), do not insulate gear casing and bearing casing.

5.1.3 Fitting the coupling



Only required when the pump unit is completed at the site of installation.

If the pump is supplied without base plate, design the base plate so that torsion and non-permitted vibrations can be safely prevented during operation. Provide height compensation for the drive.

The pump-side coupling half is pre-fitted with a transition fit as standard.



NOTICE!

Property damage due to installation errors!

- Do not tilt half-couplings when sliding on.
- Make sure that pump and motor components are not subjected to shocks or impacts.
- Do not shrink on half-couplings by heating.



In the case of couplings with an interference fit please consult the manufacturer.

1. → For detailed information and in the case of special couplings observe the manufacturer's data.
2. → Ensure that both coupling halves have the same diameter.
3. → Coat motor shaft ends with molybdenum disulphide (e.g. Molykote).
4. → Insert adjusting spring.
5. → Slide on motor-side coupling half, until the shaft end and coupling hub are flush.
6. → If available, tighten the grub screws on both coupling halves. When doing so observe the tightening torque (↺ manufacturer's data).

5.1.4 Installing the motor on base plate



Only required when the pump unit is completed at the site of installation.

If the pump is supplied without base plate, design the base plate so that torsion and non-permitted vibrations can be safely prevented during operation. Provide height compensation for the drive.

The pump-side coupling half is pre-fitted with a transition fit as standard.



NOTICE!

Property damage due to installation errors!

- Do not tilt half-couplings when sliding on.
- Make sure that pump and motor components are not subjected to shocks or impacts.
- Do not shrink on half-couplings by heating.

Materials: ■ Spacer

1. ➤ Lift motor (☞ manufacturer's instructions).
2. ➤ Place motor on base plate.
3. ➤ Bring together coupling halves. Maintain the specified gap dimension between the coupling halves (☞ dimensioned drawing).
4. ➤ Compensate the motor shaft end using suitable shims on the motor to the height of the pump shaft end.
5. ➤ Screw in the motor screws, do not yet tighten (☞ Chapter 5.5 'Aligning the pump unit' on page 32).

5.2 Preparing for installation

5.2.1 Checking the ambient conditions

1. ➤ Ensure that the required ambient conditions exist (☞ pump data sheet).
2. ➤ Ensure that no potentially explosive atmosphere exists (☞ ATEX additional instructions).

5.2.2 Preparing the installation site

- Ensure that the site of installation fulfils the following requirements:
 - Ensure the pump is freely accessible from all sides (☞ dimensioned drawing),
 - Sufficient space for installation/removal of pipe lines and maintenance and servicing work, in particular for installation/removal of the pump and motor,
 - no effects due to external vibrations on the pump system (bearing damage),
 - Frost protection,
 - Sufficient lighting.

5.2.3 Preparing the foundation and base



For installation on a concrete foundation, please consult with ITT Bornemann GmbH.

- Ensure that the foundation and base fulfils the following requirements:
- Level: Permissible deviation \varnothing dimensioned drawings, pump operating instructions,
 - Clean (no oil, dust or other contaminants),
 - Service weight of the system and all operational forces can be absorbed,
 - the stability of the pump system is ensured.

5.3 Positioning the pump unit on the foundation



For installation on a concrete foundation, please consult with ITT Bornemann GmbH.



The pump may only be mounted on a base plate (steel frame).



NOTICE!

Property damage due to base plate tension!

- A tensioned base plate may prevent coupling alignment and result in pump damage.
- Base plate on level foundation only and fasten as follows.
- It is essential to observe the alignment tolerances.

5.3.1 Placing the pump unit on the foundation

- Special tool: ■ Spirit level
- Materials: ■ Foundation bolts
■ Steel fixtures
■ Casting mortar, non-shrinking

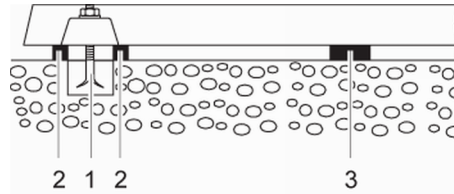

Fig. 7: Installation on a foundation (schematic diagram)

1. ➤ Lift pump unit (☞ pump system operating instructions and ☞ Chapter 4.1 'Transportation' on page 21).
2. ➤ Hook in the foundation bolts (1) into the base plate fastening holes from below.

i When using adhesive anchors: Observe the manufacturer's instructions.

3. ➤ Place the pump unit on the foundation. When doing so, sink the foundation bolts (1) into the prepared anchor holes.
4. ➤ Using steel fixtures, align the pump unit in accordance with the height and system dimensions as follows:
 - Place a steel fixture (2) to the left and right of each foundation bolt (1) respectively.
 - If the distance from the anchor holes is greater than 750 mm, locate additional steel fixtures (3) centrally on either side of the base plate.
5. ➤ Ensure that the base plate and steel fixtures lie flush.
6. ➤ Using a digital spirit level (laser alignment device), check in longitudinal and transverse directions:
 - Permissible height deviation (☞ Chapter 5.3.2 'Aligning the base plate' on page 30, dimensional drawings, pump operating instructions).
7. ➤ Repeat the process until the base plate is correctly aligned.

5.3.2 Aligning the base plate

! **NOTICE!**
Property damage due to base plate tension!

- A tensioned base plate may prevent coupling alignment and result in pump damage.
- Base plate on level foundation only and fasten as follows.
- It is essential to observe the alignment tolerances.

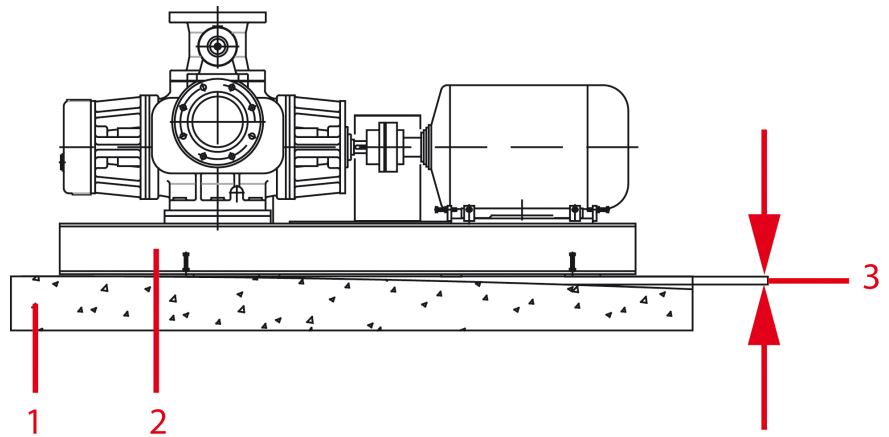

Fig. 8: Aligning the base plate (tolerances)

No.	Designation
1	Foundation
2	Base plate
3	Tolerance

Do not exceed the following tolerances for the (steel) installation points of the base plate on the foundation:

- Base plate shorter than or equal to 3 m:
 - Tolerance 1 mm, evenness of support points in relation to each other,
- Base plate longer than 3 m:
 - Tolerance 2 mm, evenness of support points in relation to each other.

5.3.3 Securing the pump unit

1. ➤ Cast the anchor holes using a casting mortar.
 - Filling with casting mortar improves the cushioning characteristics.
2. ➤ Once the casting mortar has bonded, screw the base plate tight at three points to the appropriate tightening torque.
3. ➤ Prior to tightening the remaining screws, compensate for any unevenness in the fixing surface using spacers adjacent to each screw.
4. ➤ If required, cast the inside of the base plate. Tap to check that no cavities have been created.

5.4 Mounting the pump unit without foundation

- Special tool:
- Spanner
 - Spirit level

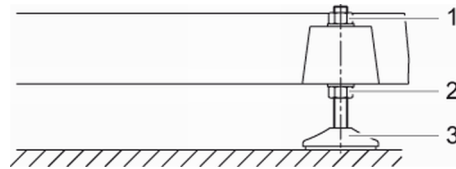

Fig. 9: Mounting without foundation (schematic diagram)

1. ➤ Lift the pump unit (↪ Chapter 4.1.2 'Lifting' on page 21).
2. ➤ Install four levelling feet (3) as shown.
3. ➤ Place the pump unit on the base.
4. ➤ Adjust the height of the base plate using levelling feet (3) as shown:
 - Hold hexagon on levelling foot (3) with spanner.
 - Loosen hexagon nut (1).
 - Adjust the height by turning the hexagon nut (2).
 - Tighten hexagon nut (1).
 - Check the permissible height deviation $< 0.33\%$ (1 cm/300 cm) using machine spirit level in longitudinal and transverse direction.
 - Repeat the process until the base plate is correctly aligned.

5.5 Aligning the pump unit



In order to determine the correct alignment tolerances it is necessary to ascertain the tolerances of the pump, coupling and motor.

For the purpose of alignment, the lowest value applies.



NOTICE!

Material damage due to incorrect coupling alignment!

- With height, lateral or angular offset: Align the motor precisely to the pump.
- For detailed information and for special couplings ↪ manufacturer's data.

5.5.1 Determining alignment tolerances

1. ➤ Determine alignment tolerances for pump.



Permissible deviations and dimensions ↪ Chapter 5.5.2 'Pump alignment tolerances' on page 33.

2. → Determine alignment tolerances for coupling.



Permissible deviations and dimensions ↪ manufacturer's data.

3. → Determine alignment tolerances for motor.



Permissible deviations and dimensions ↪ manufacturer's data.

4. → Determine the lowest value from the ascertained alignment tolerances (pump, coupling, motor) and apply this in order to align the coupling.

5.5.2 Pump alignment tolerances

Axial offset

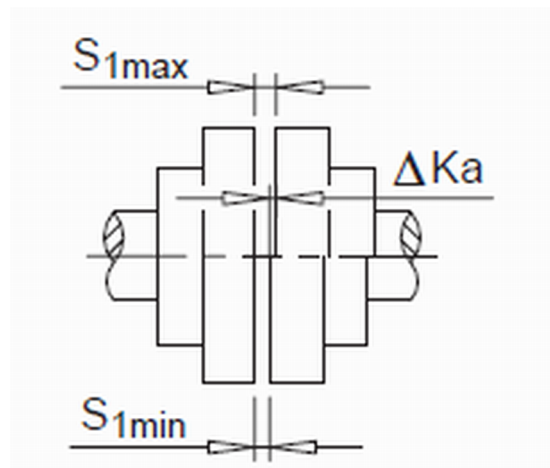

Fig. 10: Axial offset

Size	ΔK_a
SLH-4G 10xx	+1.0 mm
SLH-4G 20xx	+1.0 mm
SLH-4G 30xx	+1.0 mm
SLH-4G 40xx	+1.0 mm

Angle offset

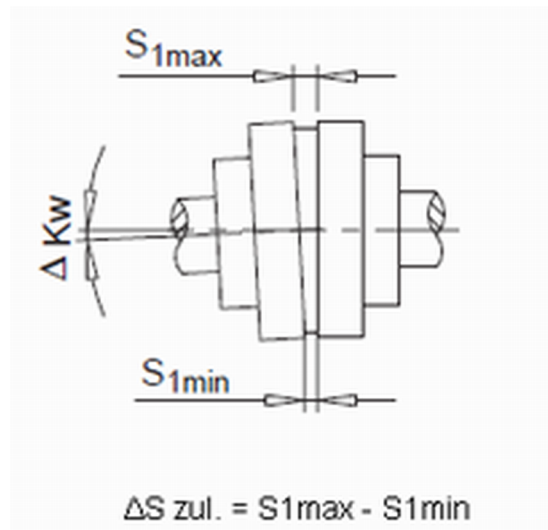

Fig. 11: Angle offset

Size	ΔS_{perm}							
	750 min ⁻¹	1000 min ⁻¹	1200 min ⁻¹	1450 min ⁻¹	1750 min ⁻¹	2000 min ⁻¹	2400 min ⁻¹	2800 min ⁻¹
SLH-4G 10xx	0.25 mm	0.22 mm	0.20 mm	0.18 mm	0.16 mm	0.15 mm	0.14 mm	0.13 mm
SLH-4G 20xx	0.28 mm	0.24 mm	0.22 mm	0.20 mm	0.18 mm	0.17 mm	0.16 mm	0.14 mm
SLH-4G 30xx	0.32 mm	0.27 mm	0.25 mm	0.23 mm	0.21 mm	0.19 mm	0.18 mm	0.16 mm
SLH-4G 40xx	0.36 mm	0.31 mm	0.28 mm	0.26 mm	0.24 mm	0.22 mm	0.20 mm	0.19 mm

Radial offset

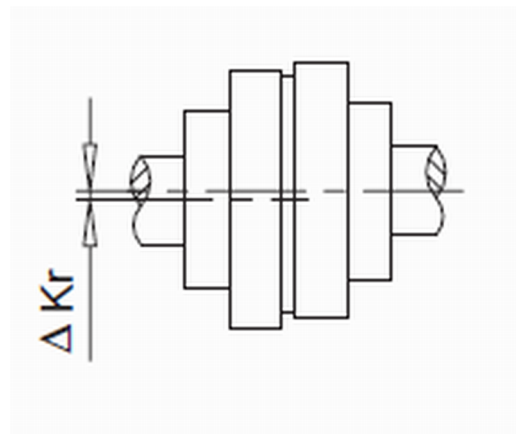

Fig. 12: Radial offset

Size	ΔS_{perm}							
	750 min ⁻¹	1000 min ⁻¹	1200 min ⁻¹	1450 min ⁻¹	1750 min ⁻¹	2000 min ⁻¹	2400 min ⁻¹	2800 min ⁻¹
SLH-4G 10xx	0.25 mm	0.22 mm	0.20 mm	0.18 mm	0.16 mm	0.15 mm	0.14 mm	0.13 mm
SLH-4G 20xx	0.28 mm	0.24 mm	0.22 mm	0.20 mm	0.18 mm	0.17 mm	0.16 mm	0.14 mm

Size	ΔS_{perm}							
	750 min ⁻¹	1000 min ⁻¹	1200 min ⁻¹	1450 min ⁻¹	1750 min ⁻¹	2000 min ⁻¹	2400 min ⁻¹	2800 min ⁻¹
SLH-4G 30xx	0.32 mm	0.27 mm	0.25 mm	0.23 mm	0.21 mm	0.19 mm	0.18 mm	0.16 mm
SLH-4G 40xx	0.36 mm	0.31 mm	0.28 mm	0.26 mm	0.24 mm	0.22 mm	0.20 mm	0.19 mm

5.5.3 Taking into account peak height changes

With cold alignment take into account peak height changes under the influence of the operating temperature according to the following figures. As soon as the pump system has reached the operating temperature following start-up, it is necessary to check the alignment (hot alignment) once again.



To determine the material design of the pump ↗ pump data sheet.

Explanation of the abbreviations

Abbreviation	Meaning
T _m	Mean temperature value $T_m = (T_2 - T_1)/2$
T ₁	Ambient temperature
T ₂	Medium temperature
ΔH	Peak height change

Peak height change

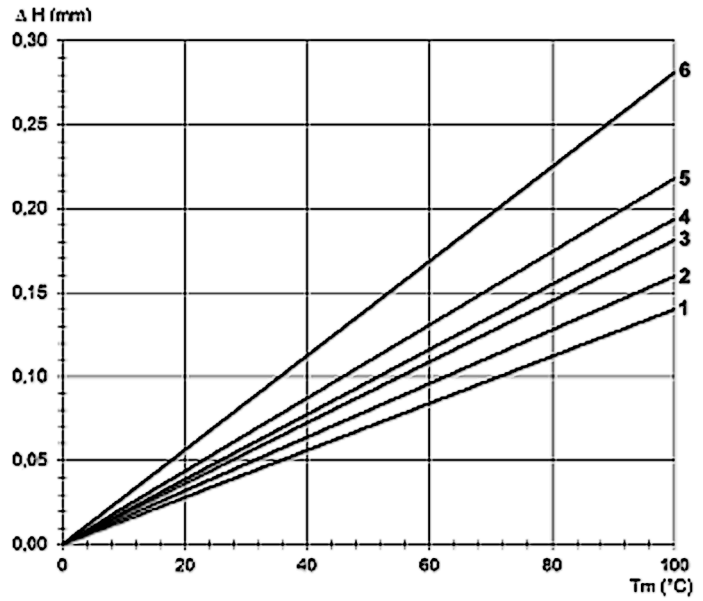

Fig. 13: Peak height change

No.	Size
1	SLH 80, SLH-4G 10xx
2	SLH-4G 20xx
3	SLH 125
4	SLH-4G 30xx
5	SLH-4G 40xx
6	SLH 180

5.5.4 Checking the coupling alignment

- Special tool:
- Laser alignment device
 - Feeler gauge
 - Straight edge
 - Dial gauge.
- Materials:
- Manufacturer's instructions

**DANGER!****Mortal danger due to moving machinery!**

- Before all installation and maintenance work: Switch off the motor and secure to prevent it being switched on again.

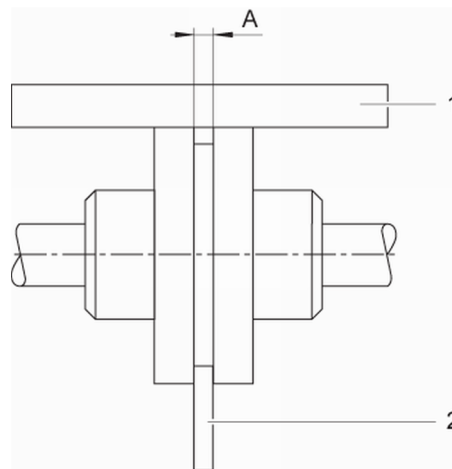

Fig. 14: Checking the coupling alignment

1. ➤ Measure the circumference of the coupling on two levels, each offset 90°.
2. ➤ Check the gap to the outer diameter with a straight-edge (1):
 - Place straight-edge over both coupling halves.
 - In case of a gap to the outer diameter, align the motor (☞ Chapter 5.5.5 'Aligning the motor' on page 38).
3. ➤ Check clearance with a feeler gauge (2):
 - Permissible clearance ☞ dimensional drawings, manufacturer's data.
 - Measure clearance (A) between coupling halves with feeler gauge.
 - In the event of impermissible clearance, align the motor (☞ Chapter 5.5.5 'Aligning the motor' on page 38).

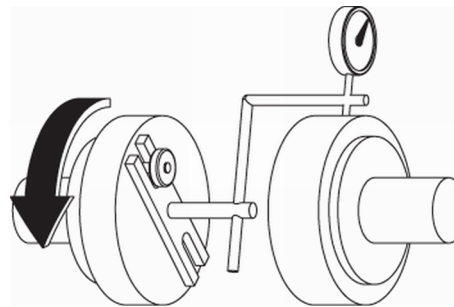

Fig. 15: Checking the lateral and height offset

4. → Check the lateral and height offset using a dial gauge:
- Carry out measurement as shown.
 - In the event of a lateral or height offset, align the motor (↪ Chapter 5.5.5 'Aligning the motor' on page 38).
Permissible axial or radial deviation, measured on the front face of the coupling or at the coupling circumference: ↪ manufacturer's data.

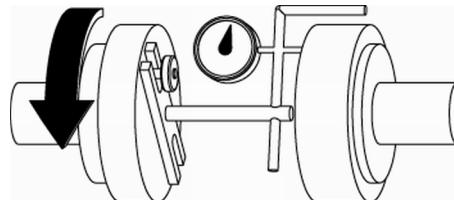

Fig. 16: Checking the angular offset

5. → Check the angular offset with a dial gauge:
- Carry out measurement as shown.
 - In the event of an angular offset, align the motor (↪ Chapter 5.5.5 'Aligning the motor' on page 38).
6. → Check the coupling alignment again and correct the motor alignment if necessary.



5.5.5 Aligning the motor



Necessary with an overly large or small clearance, or lateral, height or angular offset.

1. → Align the motor such that the coupling halves are precisely flush, if necessary position on shim plates.
2. → Check alignment.
3. → If the height offset is still evident, repeat the alignment process.
4. → Then tighten the motor screws.

5.5.6 Fitting the coupling guard

1.  If the coupling guard is not supplied fully fitted:
 - Fit the coupling guard.
 - Adjust the coupling guard to the distance between the pump and motor.
In order to do so slide the slide piece into the outer part of the coupling guard.
 - Bolt the outer part and slide piece.
2.  If a protective hood is used:
 - Ensure space between protective hood and pump/motor for ventilating the unit.

5.6 Planning pipes



Parallel operation of pumps only with express approval of ITT Bornemann GmbH.



5.6.1 Configuring supports and flange connections



NOTICE!

Property damage due to excessively high forces and torques of the piping on the pump!



- Do not exceed permissible values (☞ dimensional drawings).
- If available: Observe manufacturer's instructions for the auxiliary operating systems.

1.  Calculate pipework forces and observe all operating statuses:
 - cold/warm
 - empty/full
 - pressure-free/pressurised
 - position changes of the flange
2.  Ensure that pipe supports are constantly able to slide and do not rust and seize.
3.  Incorporate inlet and outlet-side ventilation.

5.6.2 Determining nominal widths



Keep the flow resistance in the pipework as low as possible.

1.  Observe dimensions of the inlet, outlet, auxiliary pipes (☞ dimensional drawing).
2.  Inlet line nominal width \geq Specify the inlet line nominal width.

3.  Outlet line nominal width \geq Specify the outlet line nominal width.

5.6.3 Determining pipeline lengths

-  Maintain recommended minimum values for installation of the pump.



Inlet side: shorter lengths are possible, however, doing so may restrict the hydraulic performance data.



Outlet side: shorter lengths are possible, however, doing so may lead to increased noise.

5.6.4 Optimising cross sectional and direction changes

1.  Avoid sudden changes in cross section and direction in the pipe course.



Parallel operation of pumps only with express approval of ITT Bornemann GmbH.

2.  If multiple pumps are operated in parallel and gas-charged media is being pumped:
 - Ensure that the pressure conditions are the same for each pump by running the pipes symmetrically.
 - Use identical cross sections and line lengths from the common supply line to the pumps.
3.  Ensure that no cavitation can occur.
4.  Account for thermal expansion.

In the event of advice being required regarding the optimisation of the pipe work system please contact ITT Bornemann GmbH.





5.6.5 Avoiding overpressure



WARNING!

Danger of injury due to overpressure!

- If there is no overpressure safety valve in the pump: Provide suitable safety device (e.g. burst disc) in the outlet line.

1.  Observe the manufacturer's instructions.
2.  Ensure that the factory setting of the safety device complies with the system requirements.
3.  Always guide the safety device return into the safe area (pressureless area).
4.  Constantly monitor the pressure build-up, in order to exclude impermissible pressure build-up.

5. ➤ Discharge flammable and potentially explosive pumped media safely.
6. ➤ Ensure that the pressure level in the safe area guarantees pressure relief via the safety device.

5.6.6 Including safety and control equipment

Avoiding contamination



A filter in the inlet line is also recommended during ongoing operation.



If necessary, due to the conveyed medium, the size of the filter mesh can be increased or omit the filter altogether. Hard solids must then be prevented by appropriate measures.

1. ➤ Incorporate filter into the inlet line, in accordance with the following table:

Filter for inlet line – mesh size per operating phase

Operating phase	Pump size	Mesh size [mm]
Start-up phase with initial commissioning, after maintenance work, etc.	All	1
Ongoing operation	10xx	2 – 5
	20xx	2 – 5
	30xx	2 – 5
	40xx	4 – 6
	50xx	4 – 6
	60xx	4 – 6



NOTICE!

Pump damage due to unsuitable filter!

- The use of an unsuitable filter can affect the pumping capacity of the pump and may lead to cavitation and damage to the pump.
- The filter with 1 mm mesh size is only used during commissioning and the start-up phase. This filter is unsuitable for use during operation because the mesh size is too small.
- After starting up, clean the filter and replace the filter insert. When doing so, observe the mesh size data (📄 on page 41).
- Regularly check the filter insert and filter housing for contamination and clean:
 - For prevention at least once every six months.
 - In the event of high solid content levels as necessary at shorter intervals.

2. In order to monitor the contamination include differential pressure monitoring:
 - Observe permissible differential pressure of the filter (☞ Manufacturer's instructions).

Avoiding running in reverse**NOTICE!****Property damage resulting from pump reversal.**

- Do not operate the pump without non-return protection.

1. With a safety-related component (non-return protection), make sure that the medium cannot flow back after switching off the pump.
2. Select a distance less than 2 m between the outlet nozzle and the non-return protection.

Avoiding emptying

Lay inlet and outlet lines as well as auxiliary pipes such that the pump, sealing system and lines do not empty when at a standstill.

Enabling the draining of residues**WARNING!****Risk of poisoning due to cleaning agents in the pumped medium!**

- Facilitate drainage of residue from pump and system.

Enabling cleaning

1. Lay inlet and outlet lines as well as auxiliary pipes such that there is sufficient space to install/remove the pump.
2. For pumps with axial supports:
 - Provide straight adjusting piece
 - Long adjusting piece > long pump casing (pump casing can be dismantled without any problem)
 - Arrange for pipe adjusting piece with drain hole

Enabling separation and blocking of the pipes

Include pipe connections for flushing, bleeding and emptying all relevant pipe areas (customer installation) as necessary for maintenance and servicing work.

1. Select shut-off elements, which can be secured against unintentional opening.
2. Include shut-off elements in the inlet and outlet lines.
3. Include blanking discs in the inlet and outlet lines.

Enabling measurement of the operating modes

1. ➤ Provide pressure monitoring in the inlet and outlet lines:
 - As near as possible to the pump. In doing so, maintain the limit values (☞ pump data sheet)
2. ➤ Include temperature measurement on the pump side.
3. ➤ Include dry operation protection.

CIP/SIP cleaning



NOTICE!

Damage of the mechanical seal!

- Prevent uncontrolled turning of the pump for pumps without sealing system and cleaning temperatures over 80 °C.

1. ➤ Provide CIP cleaning of the pump and lines.
2. ➤ For pumps without sealing system and cleaning temperatures over 80 °C: Prevent turning of the pump during SIP sterilisation.
3. ➤ Provide fittings for draining the pipelines.

5.6.7 Using hose lines



Observe the manufacturer's instructions.

- When using hoses, make sure that the following requirements are met:
 - Hose is suitable for the conveyed medium and pressure,
 - hose in the inlet line is suitable for suction operation,
 - heed minimum bending radius, no kinks,
 - no tensile stress,
 - hose does not twist,
 - do not guide hose over sharp edges or rough surfaces,
 - use supports for long free hose ends.

5.7 Connecting pipelines



Connections for inlet, outlet, drainage pipe and auxiliary pipes ☞ dimensioned drawing.



NOTICE!

Damage to pumps, hoses and fittings with pressure testing or rinsing!

- When carrying out pressure tests or rinsing: Do not expose pumps, hoses or fittings to impermissible pressure.
- Separate pumps, hoses or fittings from the system in advance if necessary.

5.7.1 Avoid contamination of the pipes

**NOTICE!****Property damage resulting from pump contamination!**

- Ensure that no contaminants enter the pump.

1. ➤ Prior to assembly, clean all pipe sections and valves.
2. ➤ Ensure that flange seals do not protrude inwards.
3. ➤ Remove blank flanges, plugs, protective film and/or protective paint on the flanges.

5.7.2 Install auxiliary pipes



Observe the manufacturer's instructions of any auxiliary operating systems (☞ manufacturer's documentation).

1. ➤ Install auxiliary pipes such that these are tension-free and leak-tight.
2. ➤ Avoid air pocket formation: Always lay lines such that these rise or fall towards the pump.

5.7.3 Install inlet line



1. ➤ Remove the transport locks from the pump.
2. ➤ Install inlet line.
3. ➤ Ensure that the flange seals do not protrude.
4. ➤ Attach connection for filling the pump. When doing so, ensure that the connection sizes account for the viscosity of the pumped medium.
5. ➤ Check inlet line for correct flow direction.

5.7.4 Install the outlet line

1. ➤ Remove the transport locks from the pump.
2. ➤ Install outlet line.
3. ➤ Ensure that the flange seals do not protrude inwards.
4. ➤ If no pressure safety valve is included in the system: Incorporate suitable absolute pressure limiting into the system.
5. ➤ Check outlet line for correct flow direction.
6. ➤ Equip outlet line with non-return protection (note installation direction).

5.7.5 Fitting the heating line (optional)

1. ➤ Remove the transport locks from the pump.
2. ➤ Install the fittings.





3.  Fit the heating line.
4.  Ensure that the flange seals do not protrude inwards.

5.7.6 Check that pipe connection is tension free

Prerequisite

- Pipe installed and cooled.

Procedure

1.  Disconnect the pipe connection flanges from the pump.
2.  Check that the pipe can be moved freely in all directions in the vicinity of anticipated expansion:
 - Nominal diameters < 150 mm: By hand
 - Nominal diameters > 150 mm: With a small lever
3.  Ensure that the flanges lie plane parallel.
4.  Fasten the pipe connection flanges to the pump again.
5.  Ensure that the flange seals do not protrude.

5.8 Electrical connection

5.8.1 Earth the pump



DANGER!

Mortal danger due to electric shock!

- Only allow work to be carried out on the electrical systems by a qualified electrician.
- Prior to switching on the electrical system: Earth pump system

Earth the pump

Earth the pump system to the designated earthing terminals prior to start-up, in order to prevent static charging.

The earthing connections are marked with the earthing symbol (Fig. 17).



Fig. 17: Earthing symbol



5.8.2 Connect the motor



DANGER!

Mortal danger due to electric shock!

- Only allow work to be carried out on the electrical systems by a qualified electrician.
- Prior to work on the electrics, de-energise the system and safeguard it against being switched on again.

1.  Connect the motor in accordance with the circuit diagram.
2.  Arrange for a suitable cable bushing.
3.  Ensure that no risks arise due to electrical energy.

4. ➤ Install the EMERGENCY STOP button.

5.8.3 Checking the direction of rotation



Check the direction of rotation with a field direction tester, if available.



DANGER!

Mortal danger due to moving machinery!

- Use personal protective equipment during all work on the pump.
- Secure the adjusting spring so that it cannot be ejected while testing the direction of rotation.
- Maintain sufficient distance to rotating parts.



NOTICE!

Property damage due to dry running and incorrect direction of rotation!

- Disconnect the motor from the pump.

1. ➤ Switch the motor on and immediately switch it off again.
2. ➤ Check that the motor's direction of rotation matches the direction of the arrow on the pump.
3. ➤ In the event of deviating direction of rotation:
 - Swap the two phases (☞ Chapter 5.8.2 'Connect the motor' on page 45).
4. ➤ Re-couple the motor.

5.8.4 Connecting the instrumentation



Connection of instrumentation ☞ pump system operating instructions.

6 Operation

**DANGER!****Mortal danger due to explosion!**

Observe the additional ATEX instructions!



For pumps as part of a pump system ↗ pump system operating instructions.

**NOTICE!****Irreparable damage to the pump system due to throttling on the outlet side!**

- Severe loading of the pump due to liquid sludge with throttling on the outlet side.
- Never operate the pump against a closed or partially closed valve in the outlet line.
- Never throttle the outlet side.

6.1 Performing initial commissioning

**WARNING!****Risk of injury due to unprofessional work!**

- Only allow work to be carried out by technical specialists who have the required knowledge and practical experience to do so:
 - Installation, initial commissioning, repairs, maintenance
 - Work on the electrical and electronic systems.
- Make personal safety equipment available.
- Observe statutory or other safety and accident prevention regulations.

6.1.1 Determining the pump type

→ Determine the pump type (↗ pump data sheet).



The pump type refers to e.g. the type of bearing lubrication, shaft seal type, auxiliary operating systems.

6.1.2 Commissioning after shutdown



NOTICE!

Damage to the pump due to unprofessional commissioning!

- After long-term storage, the pump should be commissioned by ITT Bornemann GmbH.

6.1.3 Removing preservative



Only necessary for preserved pumps.

- ➔ Remove preservative (☞ Chapter 4.4 'Removing preservative' on page 24).

6.1.4 Lubricating bearings/gears



Pumps with drive-side greased roller bearings are ready for use when delivered.

- ➔ Fill with lubricating oil (☞ Chapter 7.3.2 'Lubrication' on page 64).

6.1.5 Preparing auxiliary operating systems (if present)



WARNING!

Risk of injury due to the use of third-party systems!

- Use only ITT Bornemann GmbH approved auxiliary systems.

Sealing system

- ➔ Ensure that the barrier fluid is compatible with the pumped medium.
- ➔ Determine the appropriate sealing system (☞ Pump data sheet).
- ➔ Install sealing system (☞ manufacturer's documentation, pump system additional instructions).
- ➔ Ensure that the parameters have been met for the installed sealing system (☞ pump data sheet, manufacturer's documentation).

Pressure safety valve



WARNING!

Risk of injury due to pressure safety valve!

- The pressure safety valve is under pressure, do not touch.
- The pressure safety valves are configured and may not be changed.
- Ensure that the factory setting of the pressure safety valve complies with the requirements of the pump.

Heating/cooling of the casing (optional)



It is possible that the centre height of the drive shaft may change as a result of heating up. In this case, the pump unit must be realigned (☞ Chapter 5.5 'Aligning the pump unit' on page 32).

1. → Lay connections and install heating/cooling in the properly manner (☞ manufacturer's instructions).
2. → Check technical data for the heating/cooling medium (☞ job data sheet).
3. → Bleed heating/cooling.
4. → For heating/cooling, ensure:
 - Required parameters (☞ system documentation, pump data sheet, dimensional drawing)
 - Temperature difference between heating medium and conveyed medium less than 50 °C
 - Switch on pump heating at least 2 h before commissioning.

Oil lubrication system

1. → Ascertain the appropriate oil lubrication system (☞ pump data sheet).
2. → Install oil lubrication system (☞ manufacturer's specifications, pump system operating instructions).
3. → Ensure necessary operating parameters (☞ manufacturer's instructions).

6.1.6 Inertisation (for ATEX)



DANGER!



Mortal danger due to explosion!

Observe the additional ATEX instructions!



For ATEX, make sure that suitable equipment (including inertisation connections, gas measuring device, inert gas) for the inertisation of the pump and pipelines is available and ready for use.







Preparation for inertisation

1.  ■ Securely close all interfaces to the pumping process:
 - "Double block and bleed" principle
 - Blank flange
 - Spectacle blinds (secure against unintended opening)
 - Shut valves
 - Effectively disconnect the drive power for valve drives
 - Attach warning signs to manual valves that cannot be shut ("Do not open!")
 - Monitor leak-tightness with gas detectors
2.  Guide all bleeds ("Double block and bleed" principle) to the safe area.
3.  Switch off power to the drive system and secure to prevent it being switched on again.

Prerequisites for inertisation

- Preparation for inertisation (☞ 'Preparation for inertisation' on page 50) completed.
- Pump switched off and disconnected from the electrical system.
- Inlet and outlet side valves (supplied by customer) closed.

Process for inertisation

1.  Select suitable pipeline as the bleed line (at the highest point of the system) and route to the safe area.
2.  Connect the gas measuring device to the end of the previously selected bleed line.
3.  Activate gas measurement.
4.  Open the valve on the selected bleed line (bleed valve).
5.  Connect inert gas to suitable fill valve (at the lowest point of the system).
6.  Fully inertise pump and pipelines with max. 5 bar fill pressure from bottom to top until only pure inert gas flows through the bleed line.
 - ⇒ The pump and pipelines are now inertised. Before commissioning, properly fill the pump (☞ Chapter 6.1.7 'Filling and bleeding' on page 50).

6.1.7 Filling and bleeding



WARNING!

Risk of injury and poisoning due to hazardous pumped media!

- Safely contain escaped pumped media and dispose of in an environmentally friendly manner.



NOTICE!

Property damage due to dry running!

Ensure that the pump is correctly filled.



In case of flammable or explosive pumped media ☞ ATEX additional instructions.

Prerequisites for filling

- Pump correctly installed, connected and inertised (☞ *Chapter 6.1.6 'Inertisation (for ATEX)' on page 49*)
- All connections leak-tight and tension-free
- Inlet and outlet side valve (supplied by customer) closed
- Drainage valves closed.
- Auxiliary system ready for operation

Process for filling

1. ➤ Fully open inlet side valve.
2. ➤ Wait until pressure equalisation has taken place and close the inlet side valve once more.
3. ➤ Bleed pump and pipelines.
4. ➤ Repeat filling procedure until the pump has been correctly filled.
5. ➤ Close the inlet side valve.
6. ➤ Ensure that all of the connections and connecting pieces are leak-tight.

6.1.8 Switching on

Prerequisites:

- Pump correctly installed and connected
- Motor correctly installed and connected
- Motor aligned precisely to the pump
- Turning direction of the motor checked
- All connections leak-tight and tension-free
- All safety devices installed and checked for functionality
- Pump correctly prepared, inertised, filled and bled.
- If present, heating/cooling and conveyed medium at operating temperature (☞ pump data sheet)
- Auxiliary system ready for operation and switched on



DANGER!

Risk of injury due to running pump!

- Do not touch the pump when it is running.
- Do not work on the pump when it is running.
- If possible: Allow the pump to cool prior to work.



DANGER!

Risk of injury and poisoning due to hazardous pumped media!

- Use personal protective equipment during all work on the pump.



NOTICE!

Bearing damage due to overheating!

- If available, open leakage drain.
- Keep cooling fins free.
- Protect pump from direct sunlight.

**NOTICE!****Property damage due to dry running!**

- Ensure that the pump is correctly filled.

**NOTICE!****Irreparable damage to the pump system due to throttling on the outlet side!**

- Severe loading of the pump due to liquid sludge with throttling on the outlet side.
- Never operate the pump against a closed or partially closed valve in the outlet line.
- Never throttle the outlet side.

**NOTICE!****Risk of cavitation due to throttling of the media flow!**

- – Open the inlet side valve fully and do not use for regulating the pump capacity.
- Regularly check the filter for soiling.
- Maintain the viscosity of the media being pumped within the specified range (☞ Pump data sheet).

**NOTICE!****Property damage due to incorrect alignment**

● As soon as the pump system has reached the operating temperature following start-up:

- Check alignment anew!

1. ➤ Ensure that the pumped medium is at the operating temperature (☞ Pump data sheet).
2. ➤ Fully open inlet side valve.
3. ➤ Fully open outlet side valve.
4. ➤ Switch on the motor and ensure that it runs smoothly.
5. ➤ For pumps with hot conveyed medium: Ensure temperature change of less than 2 K/min.
6. ➤ After initial operation under pressure at operating temperature, check that the pump is leak-tight.
7. ➤ After reaching operating temperature, check that the alignment is correct (☞ Chapter 5.5 'Aligning the pump unit' on page 32).

6.1.9 Switching off



WARNING!

Risk of injury due to hot pump parts!

- Use personal protective equipment during all work on the pump.
- Allow the pump to cool prior to work.

1. Switch off motor. Maintain the following functions, if present:
 - Sealing system
 - Cooling water supply until pump operating temperature has dropped below 100 °C.
2. Close inlet and outlet side valves.
3. If present and permitted in the process, switch off heating.
 - The conveyed medium must not solidify.
4. At operating temperature, check coupling alignment and realign motor if necessary (↪ *Chapter 5.5 'Aligning the pump unit' on page 32*).
5. Check all connecting screws and tighten if necessary.

6.2 Operation



NOTICE!

Irreparable damage to the pump system due to throttling on the outlet side!

- Severe loading of the pump due to liquid sludge with throttling on the outlet side.
- Never operate the pump against a closed or partially closed valve in the outlet line.
- Never throttle the outlet side.

6.2.1 Preparing for operation

If necessary, carry out the following steps:

- ➔ ■ With heating: Switch on pump heating at least 2 h before commissioning.
- Prepare auxiliary operating systems (↪ *Chapter 6.1.5 'Preparing auxiliary operating systems (if present)' on page 48*).
- Clean / sterilise the pump, if necessary (↪ *Chapter 6.3 'Cleaning/sterilizing the pump' on page 55*).
- Fill and bleed pump (↪ *Chapter 6.1.7 'Filling and bleeding' on page 50*).
- Ensure that the pumped medium is at the operating temperature (↪ Pump data sheet).

6.2.2 Switching on

Prerequisite:

- First commissioning correctly completed (↪ *Chapter 6.1 'Performing initial commissioning' on page 47*).
- Operation correctly prepared.



DANGER!

Risk of injury due to running pump!

- Do not touch the pump when it is running.
- Do not work on the pump when it is running.
- If possible: Allow the pump to cool prior to work.



DANGER!

Risk of injury and poisoning due to hazardous pumped media!

- Use personal protective equipment during all work on the pump.



NOTICE!

Bearing damage due to overheating!

- If available, open leakage drain.
- Keep cooling fins free.
- Protect pump from direct sunlight.



NOTICE!

Risk of cavitation due to throttling of the media flow!

- Open the inlet side valve fully and do not use for regulating the pump capacity.
- Regularly check the filter for soiling.
- Maintain the viscosity of the media being pumped within the specified range (☞ Pump data sheet).



NOTICE!

Property damage due to dry running!

- Ensure that the pump is correctly filled.



NOTICE!

Irreparable damage to the pump system due to throttling on the outlet side!







- Severe loading of the pump due to liquid sludge with throttling on the outlet side.
- Never operate the pump against a closed or partially closed valve in the outlet line.
- Never throttle the outlet side.

1. ➤ Fully open outlet side valve.
2. ➤ Fully open inlet side valve.
3. ➤ Switch on the motor and ensure that it runs smoothly.
4. ➤ For pumps with hot conveyed medium: Ensure temperature change of less than 2 K/min.

6.2.3 Switching off

**NOTICE!****Property damage due to voltage peaks!**

- Only switch the unit off using the EMERGENCY STOP button in an emergency!

1.  Switch off motor. Maintain the following functions, if available:
 - for double ring seals: Sealing pressure, until pump is pressure-free (↺ manufacturer's specifications),
 - sealing system,
 - cooling water supply until pump operating temperature has dropped below 100 °C.
2.  Close inlet and outlet side valves.
3.  Close outlet side valves.
4.  If present and permitted in the process: Switch off heating.
 - The conveyed medium must not solidify.
5.  Open drain screw until pump is depressurised.
6.  Screw in and tighten drain screw.
7.  Clean / sterilise the pump, if necessary (↺ Chapter 6.3 'Cleaning/sterilizing the pump' on page 55).

6.3 Cleaning/sterilizing the pump



SLH and SLH-S series pumps can be cleaned/sterilised without dismantling.







Determine CIP medium and CIP temperature in accordance with the operating requirements.

**NOTICE!****Damage to pumps, hoses and fittings with pressure testing or rinsing!**

- When carrying out pressure tests or rinsing do not expose pumps, hoses or fittings to impermissible pressure.
- Separate pumps, hoses or fittings from the system in advance, if necessary.

6.3.1 CIP cleaning/sterilising at CIP temperature below 80 °C

Prerequisites:

- For pumps with sealing system: Sealing system in operation.
 - Pump stopped.
1.  Switch pipeline system to CIP medium.
 2.  Start the pump ( *Chapter 6.2.2 'Switching on' on page 53*).
 3.  Clean pipeline system and pump.
 4.  Switch off the pump ( *Chapter 6.2.3 'Switching off' on page 55*).
 5.  Remove all traces of the CIP medium.









6.3.2 CIP cleaning/sterilising at CIP temperature above 80 °C and pump with sealing system or quench system

Prerequisites:

- Sealing/quench system in operation.
- Pump stopped.

**NOTICE!****Property damage resulting from pump jamming!**

- Warm up pump whilst stationary.

1.  Switch pipeline system to CIP medium.
2.  Start the pump ( *Chapter 6.2.2 'Switching on' on page 53*).
3.  If the pump is cold:
 - Stop the pump for approx. 10 minutes.
 - Wait for casing temperature above 60 °C.
 - Restart the pump.
4.  Clean pipeline system and pump.
5.  Switch off the pump ( *Chapter 6.2.3 'Switching off' on page 55*).
6.  Remove all traces of the CIP medium.

6.3.3 CIP cleaning/sterilising at CIP temperature above 80 °C and pump without sealing system, without quench system

Prerequisite:

- Pump stopped.

**NOTICE!****Material damage due to overheated mechanical seal!**

- Only clean/sterilise pump when it is stopped.
- Cleaning time shorter than 30 minutes.



NOTICE!

Material damage due to turbine effect!

- During cleaning/sterilising due to steaming: Lock pump.

1. ➤ Switch pipeline system to CIP medium.
2. ➤ Clean pipeline system and pump.
3. ➤ Remove all traces of the CIP medium.
4. ➤ Remove the blockage.

6.3.4 Mechanically cleaning/sterilising

Prerequisites:

- Pump switched off and depressurised.
- Inlet and outlet side valves closed.
- If available: Heating/cooling switched off.
- Auxiliary operating systems switched off and depressurised.



DANGER!

Risk of injury due to running pump!

- Do not touch the pump when it is running.
- Do not work on the pump when it is running.
- Prior to all assembly and maintenance work, switch off the motor and safeguard against being switched on again.
- Prior to all assembly and maintenance work safeguard the pump against pressure charging.



WARNING!

Risk of injury and poisoning due to hazardous pumped media!

- Safely contain escaped pumped media and dispose of in an environmentally friendly manner.



WARNING!

Risk of poisoning due to cleaning agents in the foodstuffs sector!

- Only use cleaning agents that are compatible with the pumped medium.
- Use cleaning agents in accordance with manufacturer's instructions.
- Observe company's cleaning directives.



NOTICE!

Risk of property damage due to water in the bearings area!

- Seal up the bleed hole in the oil fill plug.

1. ➤ Undo inlet and outlet lines from the pump casing.
2. ➤ For pumps with axial supports: Remove pipe adjusting piece.

3. ➤ Unscrew fastening screws.
4. ➤ Pull pump casing off carefully.
5. ➤ Remove sealing ring on intermediate flange.
6. ➤ Clean/sterilise pump casing and internal parts of the pump with suitable cleaning agent.
7. ➤ Carefully slide on the pump casing over the spindles, heed the installed position of inlet and outlet nozzles (☞ dimensioned drawing).
8. ➤ Screw in and tighten fastening screws.
9. ➤ Remove the seal again on the bleed hole of the oil filling screw.

6.4 Putting out of operation



WARNING!

Risk of injury and poisoning due to hazardous pumped media!

- Use personal protective equipment during all work on the pump.
- Fully empty the pump and pipelines.
- Safely contain escaped pumped media and dispose of in an environmentally friendly manner.
- Neutralise the pumped medium residues in the pump.

6.4.1 Measures in accordance with the conveyed medium

Conveyed media behaviour	Duration of operating interruption (dependent on process)	
	short	long
sludge solids	<ul style="list-style-type: none"> ■ Emptying the pump ■ Rinsing the pump 	<ul style="list-style-type: none"> ■ Emptying the pump ■ Rinsing the pump
set/frozen, not corrosive	<ul style="list-style-type: none"> ■ Heat or empty pump, tank and pipes 	<ul style="list-style-type: none"> ■ Empty pump, tank and pipes
set/frozen, corrosive	<ul style="list-style-type: none"> ■ Heat or empty pump, tank and pipes 	<ul style="list-style-type: none"> ■ Empty pump, tank and pipes ■ Rinse pump, tank and pipes ■ Preserve pump, tank and pipes ☞ Chapter 4.2 'Preservation' on page 23
remains liquid, not corrosive	-	-
remains liquid, corrosive	-	<ul style="list-style-type: none"> ■ Empty pump, tank and pipes ■ Rinse pump, tank and pipes ■ Preserve pump, tank and pipes ☞ Chapter 4.2 'Preservation' on page 23

6.5 Recommissioning

1. ➤ Heed the manufacturer's specifications (☞ Chapter 4.4 'Removing preservative' on page 24).
2. ➤ Carry out all of the steps as per the commissioning process (☞ Chapter 6.1 'Performing initial commissioning' on page 47).

6.6 Operating the stand-by pump



Parallel operation of pumps only with express approval of ITT Bornemann GmbH.

Alternately operate the pump and stand-by pump.

Prerequisite:

- Standby pump filled and bled.
- ➔ Operate the stand-by pump at least once per week.

6.7 Disposal

Observe the national regulations applicable to disposal!



DANGER!

Risk of poisoning due to pumped medium!

- Contamination of the pump and medium-contacting parts by toxic pumped media or pumped media with naturally radioactive accompanying substances.
- Depending on the strength of contamination cleaning the medium-contacting parts may not be sufficient.
- Dispose of parts that have come into contact with media in accordance with national regulations.
- Wear personal protective equipment.



DANGER!

Risk of explosion!

- When pumping crude oil/natural gas mixtures, it is possible that deposits of iron oxide compounds may form, which are self-igniting at high temperatures and/or with flying sparks.
- With open systems, keep self-igniting material as far away as possible and dispose of correctly.
- Do not leave open systems unattended.
- Keep suitable extinguishers to hand during work.

Before disposing of the system:

- Pump switched off and separated from the electrical system.
- Inlet and outlet side valves (supplied by customer) closed.
- Carefully collect any pumped medium, operating substances and oil that leaks out and dispose of separately in accordance with locally applicable regulations.
- Pump completely emptied and rinsed.
- Neutralise pumped medium residue in the pump.
- Remove preservation (☞ *Chapter 4.4 'Removing preservative' on page 24*).
- Disassemble plastic parts and dispose of them in accordance with applicable local regulations.
- Disassemble electronic parts and dispose of them in accordance with applicable local regulations.

7 Maintenance and repairs



Trained customer service engineers from ITT Bornemann GmbH are available for installation and repairs. Upon request, present verification for the pumped material – DIN safety data sheet or declaration of no objection (↪ Chapter 9.2 'Declaration of no objection' on page 74).



DANGER!

Mortal danger due to explosion!

Observe the additional ATEX instructions!



WARNING!

Risk of injury due to unprofessional work!

- Only allow work to be carried out by technical specialists who have the required knowledge and practical experience to do so:
 - Installation, initial commissioning, repairs, maintenance,
 - Work on the electrical and electronic systems.
- Make personal safety equipment available.
- Observe statutory or other safety and accident prevention regulations.

- Use original parts or parts approved by ITT Bornemann GmbH exclusively.
- Spare parts lists and repair instructions on request, where not included in the scope of supply.

7.1 Wearing parts

Wearing parts have a limited shelf-life because of their functionality and are therefore not subject to the warranty.

Regarded as standard wearing parts are:

- mechanical seals,
- gaskets,
- roller bearings,
- radial shaft seals,
- O-rings,
- gland packings.

Regarded as long-term wearing parts are:

- shafts and conveyor screws,
- casing insert.

7.2 Monitoring



The test intervals are dependent on the pump loads.

Information about automated monitoring functions ↪ System documentation.

**DANGER!****Risk of injury due to running pump!**

- Do not touch the pump when it is running.
- Do not work on the pump when it is running.
- If possible: Allow the pump to cool prior to work.

**WARNING!****Risk of injury and poisoning due to hazardous pumped media!**

- Use personal protective equipment during all work on the pump.

1. → Check at suitable intervals:

- Temperature of bearings with metal cage (Alarm at 100 °C, shut-down at 120 °C),
- No change to the normal operating states,
- Alignment of the coupling and state of the elastic elements,
- Function of safety equipment (☞ manufacturer's specifications),
- Proper condition of the auxiliary systems,
- if available: Rupture disc is intact (☞ manufacturer's specifications),
- Sealing system and condition of the barrier fluid,
- all warning and information signs fitted and legible.

2. → Ensure for trouble-free operation:

- no dry run,
- tightness,
- no cavitation,
- valves open on inlet side,
- valves open on outlet side,
- filter free and clean,
- sufficient supply pressure,
- no unusual running noise or vibrations,
- no impermissible leakage in the shaft seal,
- function of the auxiliary systems,
- within the framework of the inspection intervals, check the rigid body vibrations, e.g. influences to the pump via foundations or pipeline connections,
- Regularly clean the surfaces in order to prevent deposits of more than 5 mm.

7.3 Maintaining

**DANGER!****Mortal danger due to electric shock!**

- Only allow work to be carried out on the electrical systems by a qualified electrician.
- Prior to work on the electrics, de-energise the system and safeguard it against being switched on again.

**DANGER!****Risk of injury due to running pump!**

- Do not touch the pump when it is running.
- Do not work on the pump when it is running.
- Prior to all assembly and maintenance work, switch off the motor and safeguard against being switched on again.
- Prior to all assembly and maintenance work safeguard the pump against pressure charging.

**DANGER!****Mortal danger due to moving machinery!**

- Ensure that the coupling guards are mounted on completion of work on the pump.

**WARNING!****Risk of injury and poisoning due to hazardous or hot pumped media!**

- Use personal protective equipment during all work on the pump.
- Allow the pump to cool prior to work, if possible.
- Ensure that the pump is pressure-free.
- Empty the pump, flush if necessary and safely contain pumped media and dispose of in an environmentally friendly manner.
- When working on the system always monitor for gas leaks using an appropriate gas detection device (fixed installation or mobile gas detection device).
- Do not work on the system alone or without regularly reporting back.
- For applications with natural radioactivity:
 - Wear breathing protection, avoid inhaling dust and absorption of solids.
 - Decontaminate or dispose of clothing after work.



Mechanical seals have a function-related leak (☞ manufacturer's instructions).

Mechanical seals are subject to natural wear, which largely depends on the respective conditions of use. It is therefore not possible to provide general information regarding the service life.



Maintenance intervals are shorter with more severe operating conditions (e.g. frequent switching on/off, high temperatures, low viscosity, aggressive environmental and process conditions).

Please note:

- Before opening the pump or system components, always ensure that the pump has been taken out of operation properly (☞ Chapter 6.4 'Putting out of operation' on page 58).

7.3.1 Maintenance table

➔ Unless otherwise necessary due to the operating mode, carry out maintenance work in accordance with the following table.

Maintenance – intervals and measures to be carried out

Interval	Module (if available)	Who	Measure
Once, after reaching operating temperature for the first time	Pump, clutch, motor	Specialist personnel	Check hot alignment (☞ Chapter 5.5.3 'Taking into account peak height changes' on page 35).
hourly, during start-up phase	Barrier system ¹⁾	Specialist personnel	<ul style="list-style-type: none"> ■ Check filter and bleed valve for soiling. ¹⁾ ■ Check filling level of barrier fluid. ¹⁾
weekly	Coupling	Specialist personnel	<ul style="list-style-type: none"> ■ Check the coupling for wear.
	Gear casing ²⁾	Specialist personnel	<ul style="list-style-type: none"> ■ Check oil level. ■ Top up/replace if necessary (☞ Chapter 7.3.2 'Lubrication' on page 64).
	Slide ring seal	Specialist personnel	<ul style="list-style-type: none"> ■ Check for leakage. ■ In the event of severe leakage: <ul style="list-style-type: none"> – Determine leakage intensity by counting the drops. – Consult manufacturer (specify leakage site and intensity). – Replace slide rings (consult the manufacturer).
	Shaft seal rings	Specialist personnel	<ul style="list-style-type: none"> ■ Check for leakage. ■ In the event of severe leakage: <ul style="list-style-type: none"> – Check oil levels at short intervals. – Determine leakage intensity by counting the drops. – Consult manufacturer (specify leakage site and intensity). – Replace shaft seal (consult the manufacturer).
	Sealing system Quench system	Specialist personnel	<ul style="list-style-type: none"> ■ Check function. ¹⁾ ■ Clean filter and bleed valve. ¹⁾ ■ Top up barrier fluid if necessary. ¹⁾ ■ If sealing/quench liquid is contaminated: <ul style="list-style-type: none"> – Check mechanical seal and renew sealing/quench liquid.
	Drive unit ¹⁾	Specialist personnel	<ul style="list-style-type: none"> ■ Check for wear. ¹⁾
	Heating (optional) ¹⁾	Specialist personnel	<ul style="list-style-type: none"> ■ Check function. ¹⁾ ■ Check tightness. ¹⁾
After the first 250 hours of operation, at the latest after 3 months	Gear casing ²⁾	Specialist personnel	<ul style="list-style-type: none"> ■ Change lubricating oil (☞ Chapter 7.3.2 'Lubrication' on page 64).
3 months	Sealing system Quench system	Specialist personnel	Change sealing/quench liquid.

Interval	Module (if available)	Who	Measure
With intermittent operation: Every 1000 hours of operation, at the latest after 6 months	Gear casing ²⁾	Specialist personnel	<ul style="list-style-type: none"> Change lubricating oil (☞ Chapter 7.3.2 'Lubrication' on page 64).
Every 6 months	Barrier system	Specialist personnel	Change barrier fluid.
With continuous operation, every 3000 hours of operation	Gear casing ²⁾	Specialist personnel	<ul style="list-style-type: none"> Change lubricating oil (☞ Chapter 7.3.2 'Lubrication' on page 64).
yearly	Gear casing ²⁾	Specialist personnel	<ul style="list-style-type: none"> Clean bleed filter. Replace if necessary.

¹⁾ Manufacturer's specifications, pump system operating instructions

²⁾ Includes bearings and gears

7.3.2 Lubrication



Heed order-based documentation (☞ system documentation).
If in doubt, the lubrication amounts specified there apply.



NOTICE!

Material damage due to incorrect lubrication!

- Ensure correct lubricant types (☞ Chapter 7.7 'Lubricant' on page 69).
- Ensure correct lubricant amounts (☞ Chapter 7.8 'Lubricant amounts' on page 69).

Changing lubricating oil



Change lubricating oil (☞ Chapter 7.7 'Lubricant' on page 69).

- Open the oil drain and drain the lubricating oil at operating temperature into a suitable collecting vessel.
- Close oil drain again and top up lubricating oil.

Filling lubricating oil

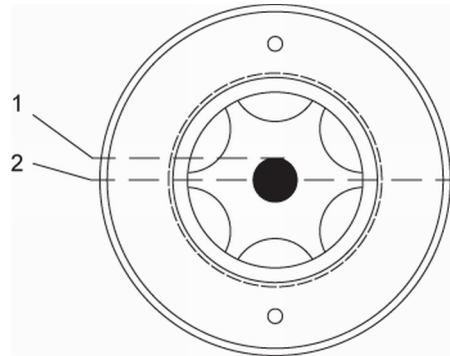

Fig. 18: Oil level gauge on gear casing or bearings hood

No.	Description
1	Maximum oil level
2	Minimum oil level

Procedure

1. ➤ Switch off pump and safeguard against a restart.
2. ➤ Let pump cool (min. 15 min cooling time).
3. ➤ Open oil filling screw.
4. ➤ Fill lubricating oil into gear casing/bearings hood until the oil level in the oil level gauge is within the specified limits.
5. ➤ Screw in oil filling screw with sealing ring.
6. ➤ Check oil level on oil level gauge and adjust if necessary.

7.4 Remove pump and send to manufacturer



Warranty claims shall be void in the event that the pump is opened by the customer during the warranty period.



DANGER!

Mortal danger due to electric shock!

- Only allow work to be carried out on the electrical systems by a qualified electrician.
- Prior to work on the electrics, de-energise the system and safeguard it against being switched on again.



DANGER!

Risk of injury due to running pump!

- Do not touch the pump when it is running.
- Do not work on the pump when it is running.
- Prior to all assembly and maintenance work, switch off the motor and safeguard against being switched on again.
- Prior to all assembly and maintenance work safeguard the pump against pressure charging.

**WARNING!****Risk of injury and poisoning due to hazardous or hot pumped media!**

- Use personal protective equipment during all work on the pump.
- Allow the pump to cool prior to work, if possible.
- Ensure that the pump is pressure-free.
- Empty the pump, flush if necessary and safely contain pumped media and dispose of in an environmentally friendly manner.

Please note:

- Before removing the pump, always ensure that the pump has been taken out of operation properly (☞ *Chapter 6.4 'Putting out of operation' on page 58*).

7.4.1 Remove pump**WARNING!****Slip hazard!**

- Clean up walkways if contaminated with leaked materials.

**NOTICE!****Property damage due to improper transportation!**

- Do not lift the pump by its bearing case or gear case.
- Ensure that the pump unit is not overly tensioned when it is lifted.
- Ensure that the lifting tackle cannot damage pipelines or units when lifting, possibly use a lifting frame (☞ *dimensional drawings, operating instructions for pump system*).
- Make personal safety equipment available.
- Observe statutory or other safety and accident prevention regulations.

Prerequisites:

- Pump switched off and safeguarded against being switched on again.
- Pump pressure-free.
- Pump completely emptied and rinsed.
- Pump disconnected from the electrical system.
- Inlet and outlet-side valves shut and safeguarded against unintentional opening.
- Pump cooled.
- Coupling guard dismantled.
- For coupling with spacer: Remove spacer.

Procedure:

- ➔ Remove the pump from the system.

7.4.2 Return pump to the manufacturer



Repair work may only be executed if the declaration of no objection has been filled out and submitted (↪ Chapter 9.2 'Declaration of no objection' on page 74).

Prerequisites:

- Pump removed.
 - Pump cooled.
 - Pump cleaned.
 - All flanges and bore holes plugged.
1. ➔ Only return pump or individual components to ITT Bornemann GmbH (↪ Chapter 9.2 'Declaration of no objection' on page 74).
 2. ➔ Depending on the desired repair, observe the required measures for return in accordance with the following table.

Measures for return

Repair	Measures for return
To be performed by ITT Bornemann GmbH	<ul style="list-style-type: none"> ■ Rinse pump and decontaminate in the event of hazardous pumped media. ■ Return complete pump (not disassembled) to ITT Bornemann GmbH. ■ Specify the following details: <ul style="list-style-type: none"> – Reason for repair – Operating conditions
With warranty claim via ITT Bornemann GmbH	<ul style="list-style-type: none"> ■ Rinse pump and decontaminate in the event of hazardous pumped media. ■ Return complete pump (not disassembled) to ITT Bornemann GmbH. ■ Specify the following details: <ul style="list-style-type: none"> – Information about occurrence of damage – Operating conditions

7.5 Repair pump



Trained customer service engineers from ITT Bornemann GmbH are available for installation and repairs. Upon request, present verification for the pumped material – DIN safety data sheet or declaration of no objection (↪ Chapter 9.2 'Declaration of no objection' on page 74).

Repair instructions can be ordered together with replacement parts for self-repairs.



DANGER!

Risk of injury due to running pump!

- Do not touch the pump when it is running.
- Do not work on the pump when it is running.
- Prior to all assembly and maintenance work, switch off the motor and safeguard against being switched on again.
- Prior to all assembly and maintenance work safeguard the pump against pressure charging.

7.5.1 Order spare parts

1. ➔ The following information is required for ordering spare parts (☞ Chapter 3.1.1 'Type plate' on page 16):
 - brief designation of the pump,
 - order number,
 - machine number/serial number,
 - item number of the part (☞ spare parts list) or TAG number (☞ manufacturer's components list),
 - name,
 - number.
2. ➔ Specify internal clearance when ordering bearings (do not use universal bearings):

7.6 Lubrication points

Oil lubrication procedure

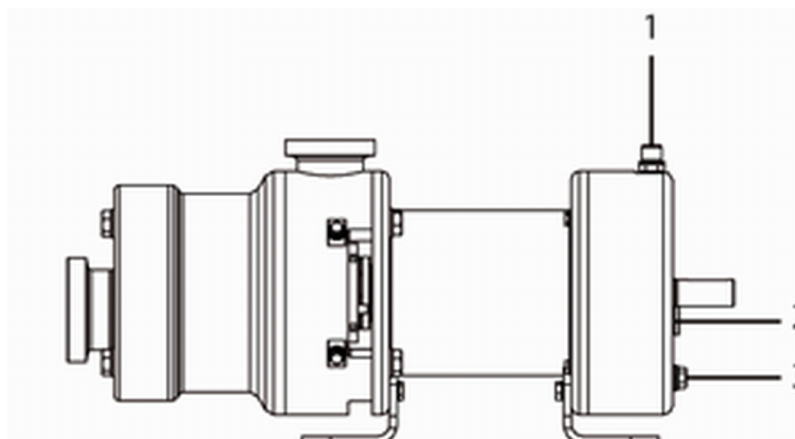

Fig. 19: Overview of lubrication points

No.	Description	No.	Description
1	Oil inlet and bleeding	3	Oil drain
2	Oil sight glass		

7.7 Lubricant



The lubricant to be used is noted on a material label on the pump.



NOTICE!

Property damage resulting from the use of incompatible lubricants!

- Only use one type of lubricant.

7.7.1 Gear oil, temperature of the medium to be pumped 10 – 300 °C



The following gearbox oils are suitable for use in the foodstuffs and pharmaceuticals sectors.

Lubricant - transmission oil

Manufacturer	Transmission oil
Finke	Lubriplate SFGO Ultra ISO VG 100
Fuchs	BEL RAY NO-TOX SYNTH. GEAR OIL 100
Klüber	Klüberoil 4 UH1-100
Shell	Cassida Fluid GL 150
Total	NEVASTANE SL 100

7.8 Lubricant amounts

Lubricant amounts

Size	approx. oil quantity [l]
10xx	0.30
20xx	0.50
30xx	0.90
40xx	1.50
50xx	4.70
60xx	5.40

7.9 Preservative agents

Manufacturer	Preservative agents	
	oily	waxy
Finke	Pharmawhite W – 00	-

7.10 Cleaning fluid



The specified cleaning agents are only suitable for external cleaning. Cleaning agents for the interior are available on request.

Area of application	Cleaning fluid
Other	Cleaning solvent, wax remover, diesel, petroleum, alkaline cleaner

8 Fault finding

Faults that are not specified in the following table or which are not traceable to one of the specified causes should be discussed with ITT Bornemann GmbH.

The list of possible faults are given with a number in the following table. This number can be used to look up the cause and measure for rectification in the faults table.

Fault	Number
Pump fails to convey.	1
Pump conveys insufficiently.	2
Pump conveys excessively.	3
Pump runs unevenly or extremely loudly.	4
Pump jams.	5
Pump leaks.	6
Power consumption of the motor too high.	7

Fault table

Fault number							Cause	Remedy
1	2	3	4	5	6	7		
X	X	-	-	-	-	-	Excessive play between: <ul style="list-style-type: none"> Conveyor screws Conveyor screws and housing 	<ul style="list-style-type: none"> Repair or exchange worn parts. Consult with ITT Bornemann GmbH.
X	-	-	X	-	-	-	Delivery/inlet side valve closed by valve.	<ul style="list-style-type: none"> Fully open valves.
X	-	-	X	-	-	-	Pump not completely filled.	<ul style="list-style-type: none"> Completely fill pump (☞ <i>Chapter 6.1.7 'Filling and bleeding' on page 50</i>).
X	X	-	X	-	-	-	Speed too low.	<ul style="list-style-type: none"> Increase speed with speed regulator.
X	X	-	X	-	-	-	Delivery/inlet line, pump or filter blocked or encrusted.	<ul style="list-style-type: none"> Clean delivery/inlet line, pump or filter. Check filter mesh size and change if necessary, in consultation with ITT Bornemann GmbH.
X	-	-	X	-	-	-	Uncontrolled opening of the safety valve.	<ul style="list-style-type: none"> Check and, if necessary, adjust the safety valve setting.
X	-	X	X	-	-	-	Pump direction of rotation incorrect.	<ul style="list-style-type: none"> Check and, if necessary, adjust the drive's direction of rotation (☞ <i>Chapter 5.8.3 'Checking the direction of rotation' on page 46</i>).
X	-	-	X	X	-	X	Pump contaminated.	<ul style="list-style-type: none"> Consult with ITT Bornemann GmbH.
X	X	-	X	.	.	X	Outlet line blocked.	<ul style="list-style-type: none"> Clean outlet line.
X	X	-	X	X	X	X	Connecting screws not properly tightened.	<ul style="list-style-type: none"> Tighten connecting screws.
X	X	X	X	X	X	X	Viscosity or temperature of the conveying medium deviates from the pump's design data (☞ pump data sheet).	<ul style="list-style-type: none"> Consult with ITT Bornemann GmbH.
-	X	-	X	-	-	-	Cross section of the inlet or outlet line too narrow.	<ul style="list-style-type: none"> Increase cross section. Clean inlet or outlet line of deposits.

Fault number							Cause	Remedy
1	2	3	4	5	6	7		
-	X	-	X	-	-	-	Temperature of the conveyed medium too high: Pump cavitating.	<ul style="list-style-type: none"> ■ Lower temperature. ■ Adjust speed. ■ Consult with ITT Bornemann GmbH.
-	X	-	X	-	-	X	Outlet side valve insufficiently opened.	<ul style="list-style-type: none"> ■ Fully open outlet side valve.
-	-	X	X	-	-	X	Speed too high.	<ul style="list-style-type: none"> ■ Lower speed with speed regulator.
-	-	-	-	-	X	-	Pump leaking.	<ul style="list-style-type: none"> ■ Consult with ITT Bornemann GmbH.
-	-	-	X	-	-	-	Coupling elements worn. Coupling not properly aligned.	<ul style="list-style-type: none"> ■ Check and, if necessary, replace the coupling elements. (☞ Chapter 5.5 'Aligning the pump unit' on page 32)
-	-	-	X	-	-	-	Insufficient oil in gear casing.	<ul style="list-style-type: none"> ■ Top up oil. (☞ Chapter 7.3.2 'Lubrication' on page 64).
-	-	-	X	-	-	-	Insufficient oil in bearing casing.	<ul style="list-style-type: none"> ■ Top up oil. (☞ Chapter 7.3.2 'Lubrication' on page 64).
-	-	-	X	X	-	-	Pipelines too tight.	<ul style="list-style-type: none"> ■ Check pipework. ■ Connect pipelines so that they are slack.
-	-	-	X	X	-	X	Expansion of the internal pump components under excessive temperatures.	<ul style="list-style-type: none"> ■ Wait for the temperature to equalise.
-	-	-	X	X	-	X	Bearings/gears faulty.	<ul style="list-style-type: none"> ■ Consult with ITT Bornemann GmbH. If necessary, send the pump to ITT Bornemann GmbH.
-	-	-	X	X	-	X	Pump excessively tight.	<ul style="list-style-type: none"> ■ Check the connections and pipeline nozzles and fastenings on the pump. ■ Check the alignment of the coupling. ■ Check the fastening of the support. ■ Check foundation.
-	-	-	X	X	-	X	Motor bearings faulty.	<ul style="list-style-type: none"> ■ Consult the manufacturer.

9 Appendix

9.1 Technical data



Additional technical data ↗ pump data sheet.

9.1.1 Ambient conditions



Consult the ↗ pump data sheet or contact ITT Bornemann GmbH.

- Temperature max. 40 °C, min. -10 °C (or ↗ pump data sheet).
- Installation above sea level max. 1000 m.

9.1.2 Noise level



Measurements carried out as per DIN 45635, Part 1. The emission values have been determined under reproducible conditions in accordance with DIN 45635, Part 24. The measurement is based on a single screw pump.

The specified sound levels are approximate values.

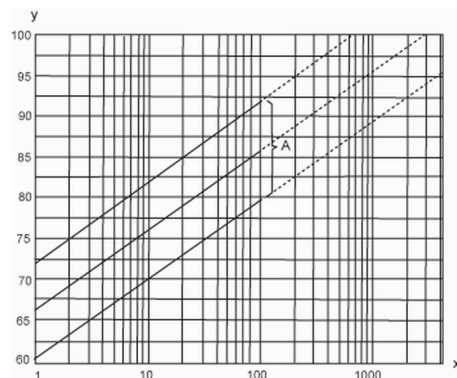

Fig. 20: Airborne sound level diagram (source: VDI 3734)

Letter	Description
x	Output demand [kW]
y	Airborne sound level measurement surface LpA [dB]
A	Scatter band

9.2 Declaration of no objection



Please copy and send with the pump.

Declaration of no objection

Statutory regulations oblige all commercial companies to protect their employees, the public and the environment from the hazardous effects of dangerous substances.

For this reason, repair and inspection of the products and their parts may only be undertaken once the following declaration has been correctly and fully filled out and signed by an authorised, qualified engineer.

If safety measures must be employed despite complete emptying and cleaning on the part of the operator, then this required information must be passed on. This declaration of no objection comprises part of the repair or inspection order.

We hereby declare that the enclosed device

Type: _____

Serial number: _____

- is free of hazardous materials. Special safety measures for further handling of the device are not necessary.
- The device has been fully emptied and thoroughly cleaned inside and out prior to dispatch.

The following media was previously conveyed by _____
the pump:

The medium was hazardous: YES NO

The pump was emptied by the operating firm: YES NO

The pump was thoroughly cleaned inside and out by the operating firm: YES NO

The pump came into contact with hazardous substances: YES NO

If yes: Hazardous material number according to Ordinance on Hazardous Substances (GefStoffV): _____

or CAS registration number (Chemical Abstract Service): _____

Company/Institute: _____

Street: _____

Postcode, city: _____

Telephone: _____

Name: _____

Item: _____

Date: _____

Signature,
company stamp: _____

9.3 Declaration in accordance with the EC machinery directive

9.3.1 Declaration of conformity in accordance with the EC machinery directive



The following declaration does not contain a serial number or signatures. The original declaration is supplied with the respective pump.

Declaration of conformity

EG declaration of conformity in accordance with Machinery Directive 2006/42/EC appendix II A

We hereby declare,

ITT Bornemann GmbH

Postbox 1162, 31676 Obernkirchen

Tel. +49 (0) 5724-390-0, Fax +49 (0) 5724-390-290,

that the following machine:

Serial number: _____

Name: _____

Year of manufacture: _____

conforms with the following EC directives, insofar as the prerequisites for commissioning stated in the engineering document, in particular in the operating instructions, are fulfilled:

- Machinery Directive (2006/42/EC),
- Low Voltage Directive (2006/95/EC),
- EMC directive (2004/108/EC).

(The applicable directives are marked.)

Applied harmonised standards:

- EN 349:1993+A1:2008
- EN 953:1997+A1:2009
- EN 13732-1:2008
- EN 1672-2:2005+A1:2009
- EN 13951:2012
- EN 12162:2001+A1:2009
- EN ISO 12100:2010
- EN 809:1998+A1:2009+AC:2010
- EN ISO 14159:2008

Applied harmonised standards for operation in an explosion-prone area:

- EN ISO 1127-1:2011
- EN 13463-1:2011
- EN 13463-5:2011
- EN 13463-6:2005

Authorised for the compilation of the documentation verifying conformity:

ITT Bornemann GmbH

Postfach 1162

31676 Obernkirchen

Company stamp/signature:

Company stamp/signature:

Head of Engineering

Head of Sales

9.3.2 Declaration of incorporation in accordance with the EC machinery directive



The following declaration does not contain a serial number or signatures. The original declaration is supplied with the respective pump.

Declaration of incorporation

EG declaration of incorporation in accordance with Machinery Directive 2006/42/EC appendix II B

We hereby declare,

ITT Bornemann GmbH

Postbox 1162, 31676 Obernkirchen

Tel. +49 (0) 5724-390-0, Fax +49 (0) 5724-390-290,

that the following incomplete machine:

Serial number: _____

Name: _____

Year of manufacture: _____

complies with the following essential requirements of the machinery directive (2006/42/EC):

Annex I, articles 1.1.2, 1.1.3, 1.1.5, 1.3.2, 1.3.3, 1.3.4, 1.3.7, 1.7.3.

Applied harmonised standards:

- EN 349:1993+A1:2008
- EN 953:1997+A1:2009
- EN 13732-1:2008
- EN 1672-2:2005+A1:2009
- EN 13951:2012
- EN 12162:2001+A1:2009
- EN ISO 12100:2010
- EN 809:1998+A1:2009+AC:2010
- EN ISO 14159:2008

Applied harmonised standards for operation in an explosion-prone area:

- EN ISO 1127-1:2011
- EN 13463-1:2011
- EN 13463-5:2011
- EN 13463-6:2005

Commissioning is prohibited until such time as it has been determined that the machine into which this machine is to be incorporated corresponds with the terms of the respective Directive (2006/42/EG).

Furthermore, we hereby declare that the special technical documents for this incomplete machine have been generated per annex VII part B and we undertake to pass over a copy of these to the market surveillance authorities upon request.

Authorised for the compilation of this documentation:

ITT Bornemann GmbH

Postfach 1162

31676 Obernkirchen

Company stamp/signature:

Company stamp/signature:

Head of Engineering

Head of Sales



www.ampcopumps.com | www.bornemann.com

03/2020 M-042 REV A