

Ampco Pumps Company

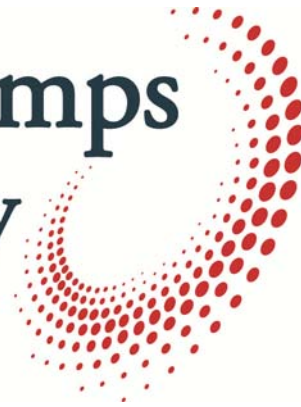

Ampco AL Series

- Positive Displacement Pumps
 - Installation and Maintenance Manual

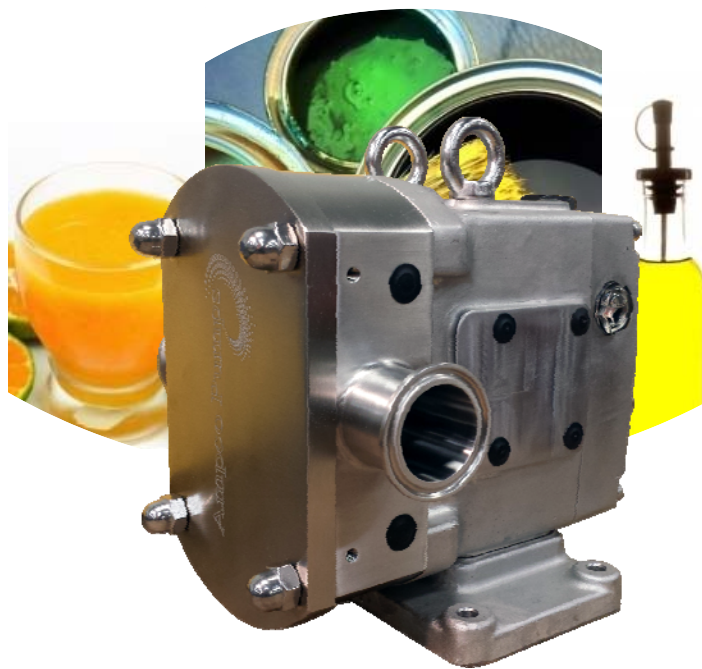

Table of Contents

Ampco Pumps Company

Introduction	3
Introduction	3
General Information	3
Shipping Damage or Loss.....	3
Receiving/Safety	4
Pump Receiving.....	4
Safety.....	4
Pump Information	5
Pump Information.....	5
Label Information	6
Installation	7
Installation.....	7
Base Arrangement.....	7
Piping and Connections.....	8
Check/ Isolation/ Relief Valves	9
Strainers and Gauges	10
Base Alignment.....	10
Pump Rotation	11
Final Installation	11
Maintenance	12
Maintenance	12
Pump Lubrication	12
Preventive Maintenance/ Inspection	13
Gear and Bearing Inspection	14
Annual Maintenance	15
Cleaning.....	15
Pump Disassembly	16
Seal Maintenance	17
Single O-Ring Seal.....	17
Double O-Ring Seal	18
Single Mechanical Seal.....	19
Double Mechanical Seal	20
Lip Seal (Double or Triple)	22
Mechanical Seal with Flush (Lip Seal)	23
Gear Case Maintenance	24
Disassembly.....	24
Assembly.....	26
Pump Assembly	31
Pump Clearances	33
Ampco Pumps Available Options	34
Troubleshooting	36
ATEX Certification Information	39
Terms and Conditions	40
Return Policy	43

Introduction

To ensure the best results and service, please read and fully understand this manual prior to putting this pump into service. For any questions regarding operation, maintenance, or installation, please contact your local distributor or Ampco Pumps Company:

*Ampco Pumps Company
2045 W. Mill Road
Glendale, WI 53209
Phone: (800) 737-8671 or (414) 643-1852
Fax: (414) 643-4452
Email: ampcocs@ampcopumps.com*

General Information

Each Ampco AL pump is fully assembled, lubricated, and tested at the factory and shipped ready for use. Standard maintenance practices are outlined in this manual. For more information, please refer to the Maintenance Section. Following these guidelines will provide long-lasting, trouble-free service when the pump(s) is incorporated in a properly designed system.

If deemed necessary to return a product under warranty, or for any other reason, contact Ampco Pumps to receive a Returned Material Authorization (RMA) number to allow us to expedite this request as quickly as possible.

Shipping Damage or Loss

Upon receiving equipment that is damaged or if your shipment is lost in transit, immediately file a claim with the carrier. At time of pick-up, the carrier signed the bill of lading, acknowledging that they have received the product from Ampco in good condition.

Pump Receiving

Ampco covers the pump inlet and discharge ports prior to shipping, ensuring that foreign matter does not enter the pump during shipment. If the protective covers are missing upon arrival, remove the pump cover and inspect to ensure it is free from contaminate before turning the shafts. Please make note of the pump serial number; this will assist in the process of ordering replacement parts and/or a warranty claim. For more information regarding shipment damage or warranty, please refer to the Introduction/Warranty section in this manual.

Safety

IMPORTANT: Read and understand this manual **BEFORE** installation, operation, or maintenance of the pump. Improper installation, operation, or maintenance may result in severe injury or death. Equipment damage caused by user neglect will invalidate the pump warranty.

There are safety symbols used throughout this manual identifying safety concerns.



WARNING: Hazards or unsafe practices that COULD result in severe personal injury or death, and how to avoid them.

CAUTION: Hazards or unsafe practices that COULD result in minor personal injury or damage to product or property.

Pump Information

The design of the AL pump gear case allows for the shaft location to be universal in order to fit any system requirement. This can be seen in Figures 1 and 2:

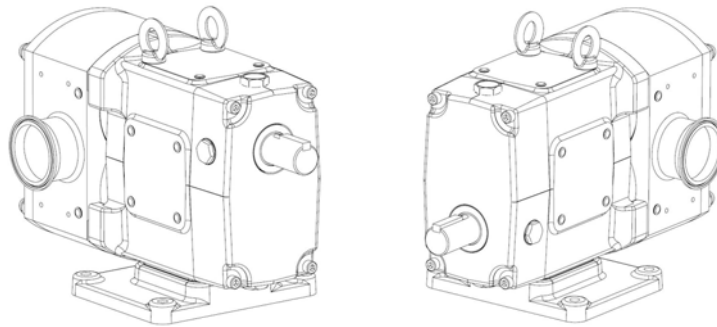

Figure 1: Horizontal Ports (Upper Shaft and Lower Shaft Mounts)

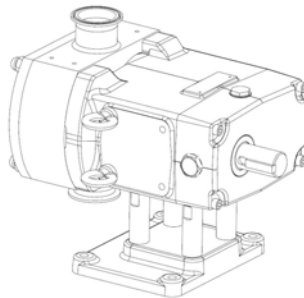

Figure 2: Vertical Ports (Right Side Shaft Mount)

**Table 1:
Standard
Operating
Parameters**

Model	Displacement		Maximum Differential Pressure		Temperature Range		Standard Connection Size		Maximum Speed
	Gal. / 100 rev	Liters / rev	PSI	Bar	°F	°C	in.	mm	Rev/min
AL05	0.53	0.02	290	20	-40° to 250°	-40° to 121°	1"	25	1000
AL10	0.85	0.03	290	20			1.5"	38	1000
AL15	2.50	0.09	175	12			1.5"	38	800
AL20	5.00	0.19	115	8			1.5"	38	800
AL22	10.56	0.40	175	12			2"	51	700
AL25	16.37	0.62	115	8			2.5"	64	700
AL33	26.90	1.02	175	12			3"	76	600
AL34	37.98	1.44	115	8			4"	102	600
AL44	59.88	3.34	175	12			4"	102	500
AL46	88.10	3.34	115	8			6"	152	500

- For operating parameters that fall outside the standard values defined in Table 1, please contact the Engineering Department at Ampco Pumps Company (414-643-1852).
- Standard rotors operate within a temperature range of -40 °F to 250 °F. Hot clearance rotors operate between 250 °F to 375 °F. Consult Ampco Pumps for questions on application factors such as temperature, operational speed, and differential pressure.

Rectangular Flange Model

The AL series pump can be modified to have a rectangular inlet (Figure 3). Please consult Ampco Pumps for questions on application factors and dimensional information.

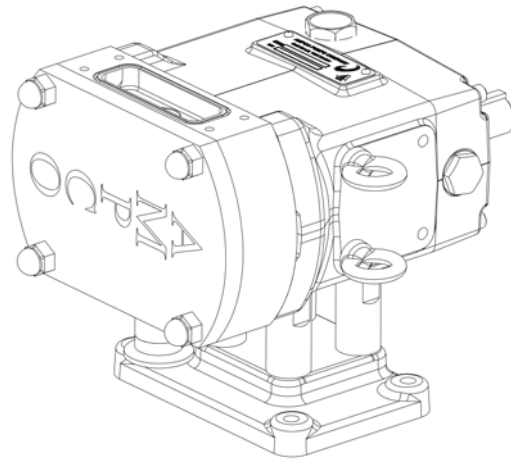

Figure 3: Rectangular Inlet Option

Label Information

The pump is installed with a simple, but effective identification plate. This identification plate is applied at the factory to help track the life of the pump. The customer should be aware of the pump’s serial number and model number prior to contacting Ampco Pumps with any concerns. The identification plate location can be seen below in Figure 4.

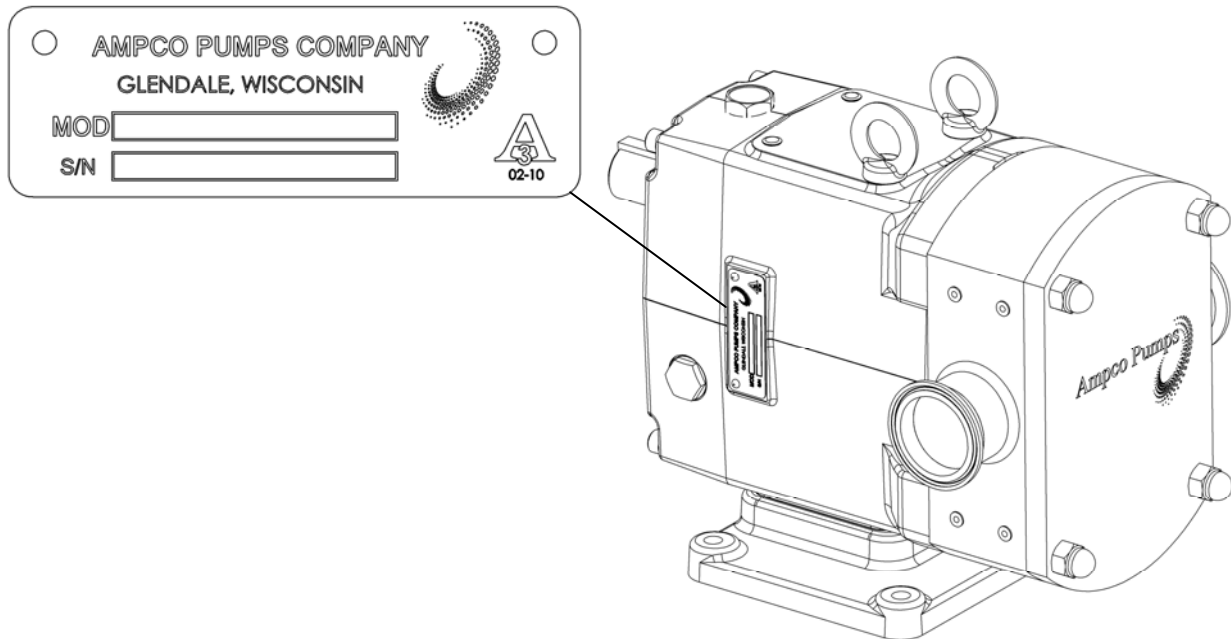

Figure 4: Important Label Information

Installation

Follow local codes and restrictions when installing the pump and piping system. The practices outlined in this manual are intended to ensure the most optimal performance of the pump.

Base Arrangement

The standard installation arrangement for a pump of this type consists of both the pump and drive unit mounted on the same base plate. Typical base plate arrangements consist of permanently fixed bases, bases with leveling and/or vibration isolation pads, bases with attached adjustable legs, or portable/wheeled bases. All base arrangements must be level during operation. Standard base configurations (base, pump, coupling, coupling guard, gear reducer, and motor) can be seen below in Figure 5.

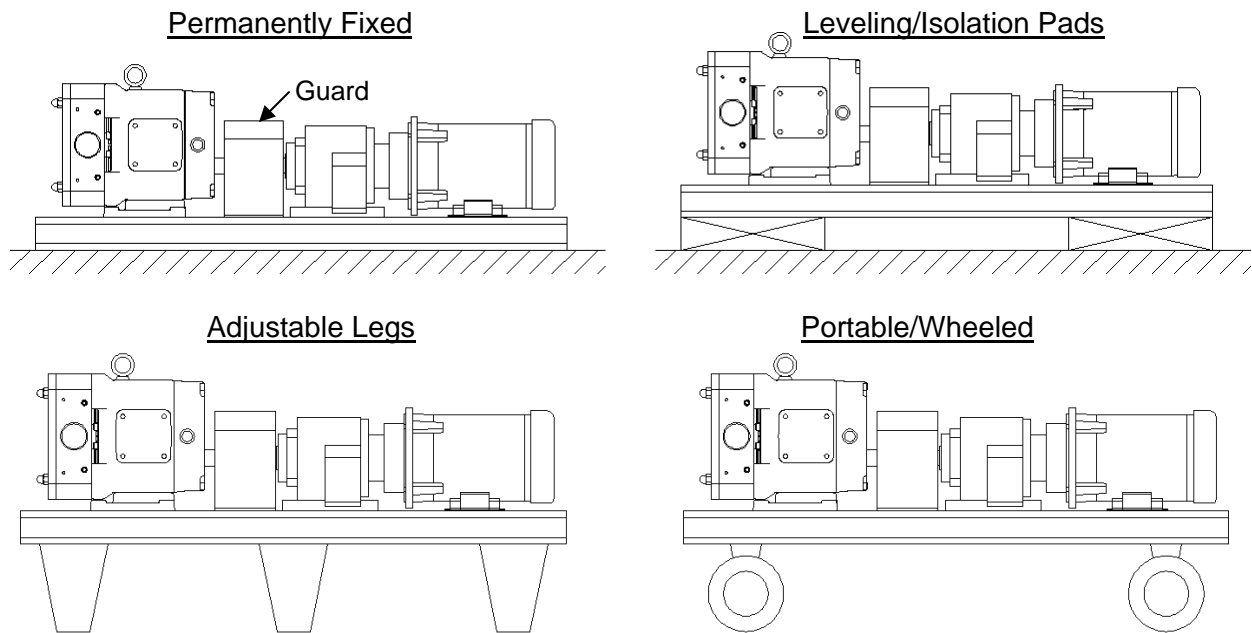

Figure 5: Base Layout Examples



WARNING: To ensure safety, protective guards must be properly installed over all external rotating parts and components. Failure to do so may result in injury. Ampco Pumps provides protective guards for complete base packages (pump and drive unit).

Piping and Connections

It is important to minimize forces imposed on the pump. This can be done by independently supporting the piping going to and from the pump. Excessive force applied to the pump can cause misalignment of internal parts which leads to the premature wear of rotors, bearings, and shafts. The use of hangers and pedestals on connecting pipes will help avoid such misalignment. Examples of such supports can be seen in Figure 6.

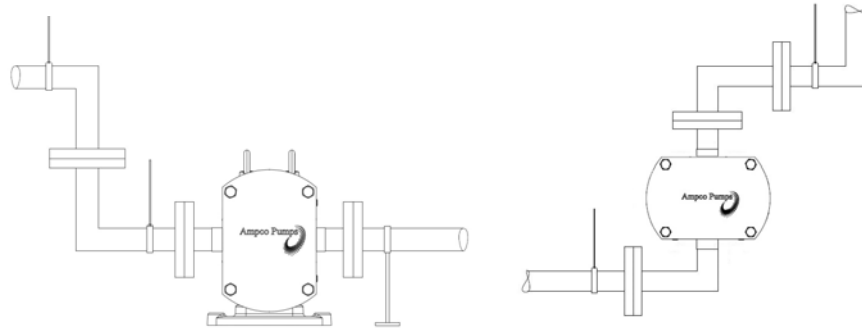

Figure 6: Piping Support Example

It is not recommended to weld custom fittings outside the factory. Shrinkage and warpage can occur to the pump housing which will affect the life and performance of the pump.

To prevent air pockets from entering the pump from the inlet, install the pump below the supply (Figure 7). This will create a constant supply of product on the suction side and reduce the chance for air to enter the pump. Sloping the piping on the inlet side away from the pump will prevent air pockets if the pump is installed above the supply (Figure 8).

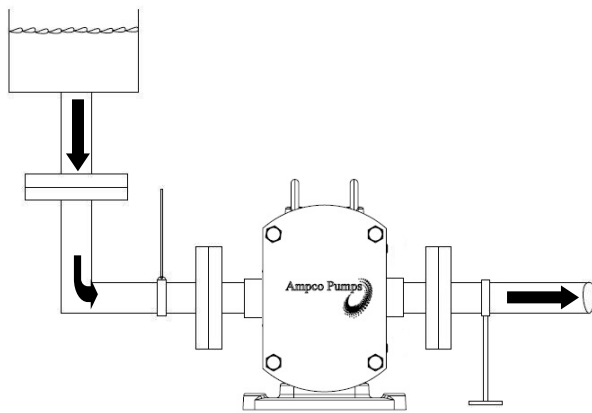

Figure 7: Correct Piping (Supply Above)

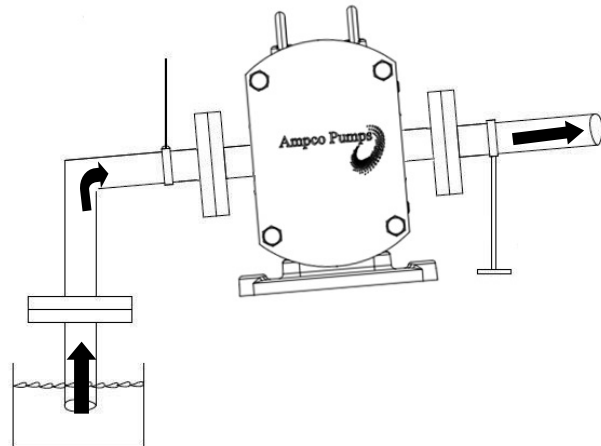

Figure 8: Correct Piping (Supply Below)

Check/ Isolation/ Relief Valves

Check valves should be used on the inlet side for any application where the product is lifted (Figure 9). This is to ensure a full inlet and is especially important with low-viscosity fluids. If the system has liquid under a vacuum, such as closed tank applications, it is important to have a check valve on the discharge side to prevent backflow during initial start-up (Figure 10).

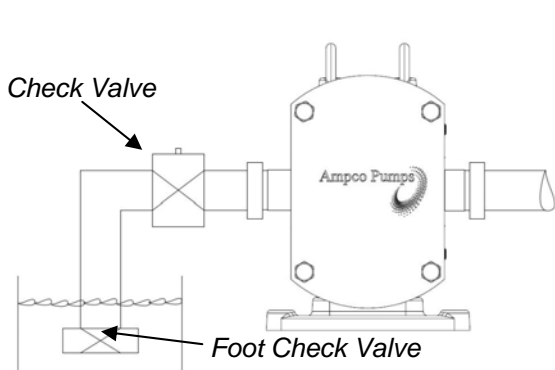

Figure 9: Check Valve (Inlet Side)

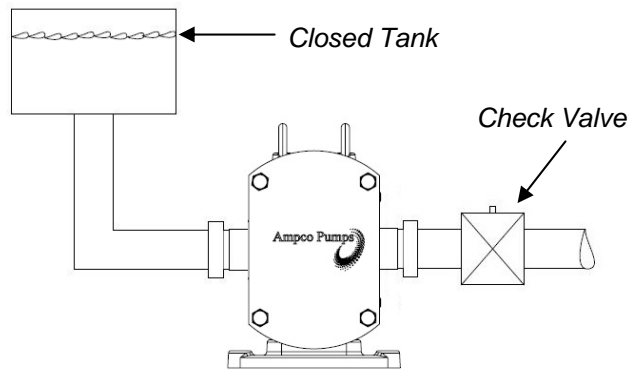

Figure 10: Check Valve (Discharge Side)

When shut down time is not possible, a bypass system may be installed with a backup pump in parallel series to allow production to continue while maintenance is performed on the down pump. Isolation valves may also be used on both the inlet and discharge sides of the pump to shut down the flow of product to the pump. This will allow for maintenance and removal of the pump without draining the entire system and risking the loss of product.



CAUTION: Ampco's AL positive displacement pumps are designed with extremely tight tolerances allowing only low slip internally between rotors and pump housing. DAMAGE will occur if the pump is operated with discharge or inlet lines closed. **DO NOT** operate pump with lines closed.

In order to prevent damage to the pump, it is recommended a relief valve be installed on the pump's discharge side. The relief valve can either divert flow into a drain or back to the inlet side (Figure 11).

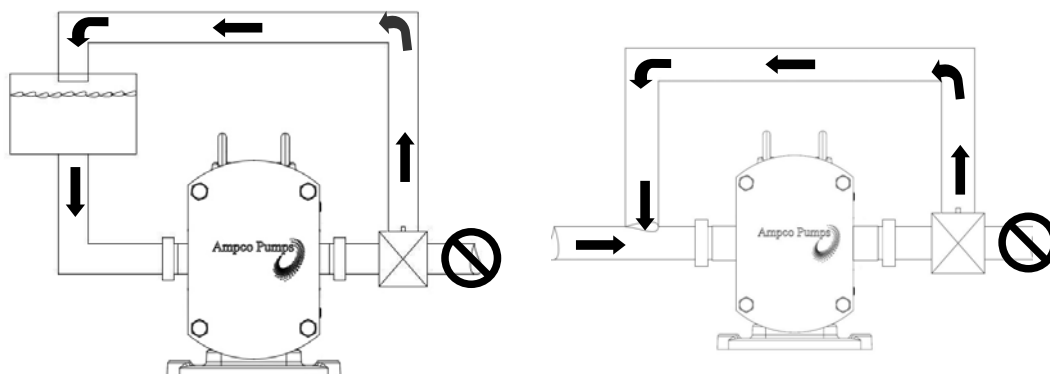
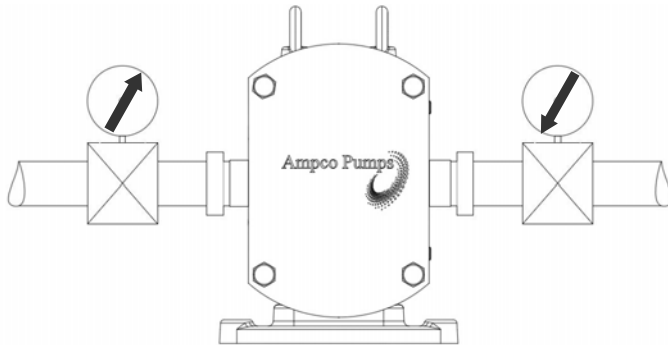

Figure 11: Relief Valve Examples

Strainers and Gauges

Strainers and magnetic traps should be used to prevent foreign matter from entering the pump. It is essential to service strainers and traps regularly to prevent restriction of flow. To determine the performance of the pump, install pressure and vacuum gauges on the inlet and discharge piping (Figure 12).



Proper Gauging Shows:

- Unusual pressure variations
- Indicates flow
- Changes in pump performance
- Variations in the system
- Differences in fluid viscosities

Figure 12: Proper Gauging

Base Alignment

Pump and base assemblies sent directly from Ampco's factory are aligned prior to shipment. Assemblies must be checked once they are installed and prior to operation. Misalignment may cause unnecessary wear and shorten the life of the pump. If couplings are not specified, Ampco will use a flexible coupling which permits minor compensation for alignment and endplay.

To check the coupling alignment, start with checking the angular alignment by measuring the gaps between the couplings on both the pump and motor side (Figure 13, Angular Alignment). Shim the assembly accordingly so the gap is equal distance at all points. Next, using a straight edge, check the horizontal and vertical alignment of the coupling. Place the straight edge along the coupling to ensure that both sides are concentric (Figure 13, Parallel Alignment).

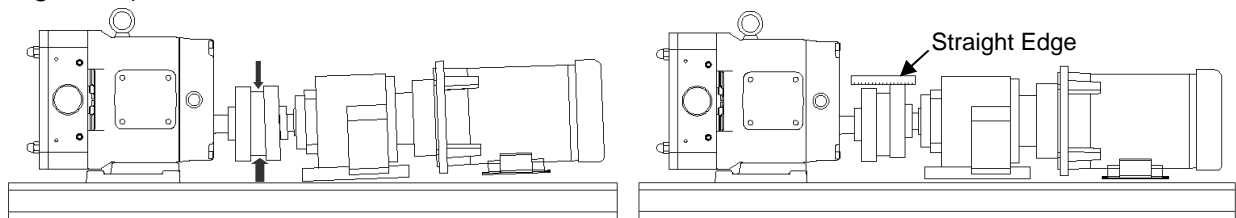

Angular Alignment

Parallel Alignment

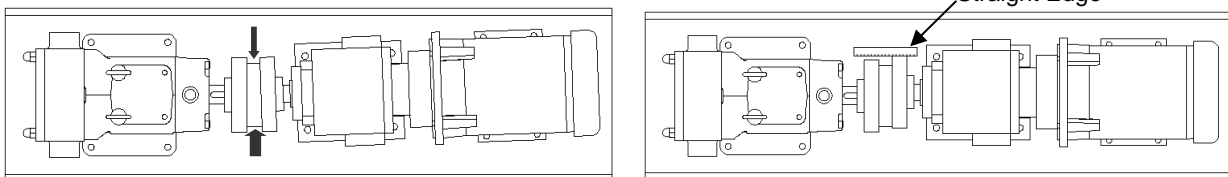

Figure 13: Check Alignment

Pump Rotation

Check the direction of rotation (both on drive unit and pump) prior to connecting the pump to the drive. This will ensure correct product flow at start-up (Figure 14 and Figure 15). Also check that the pump turns freely and is free of any foreign contaminants. Connect the pump and check to make certain all guards are in place.

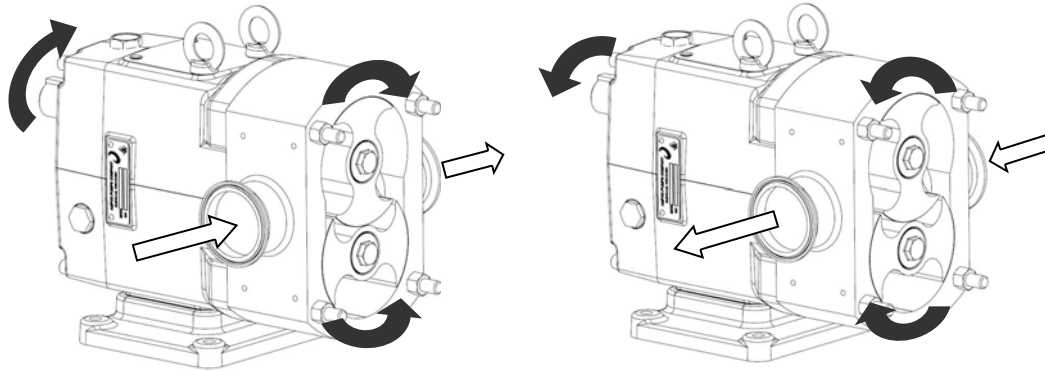

Figure 14: Top Drive Shaft

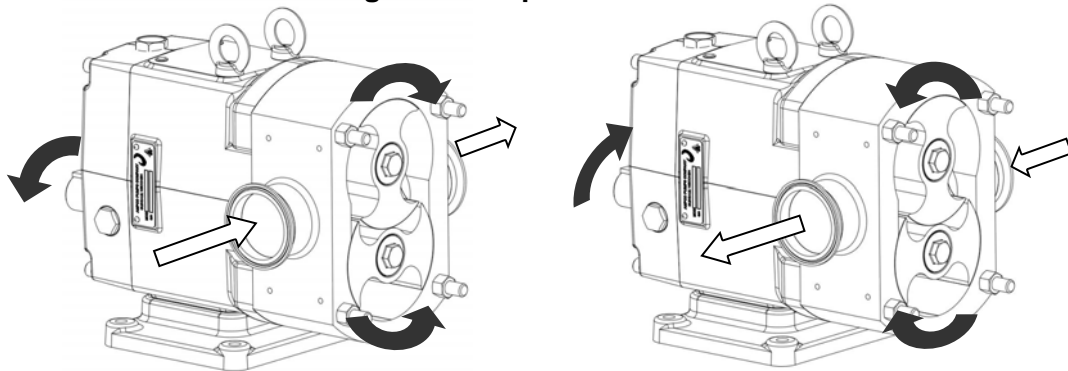

Figure 15: Bottom Drive Shaft

Final Installation

For pumps with a double seal or a flush lip seal, connect the seal flushing before operation. Operation of the pump without proper flushing will **damage** seal faces. Flushing connections are typically 1/8" female NPT with one side being the inlet and the other the discharge. Flush from the bottom to the top, using the lower connection as the inlet and the upper connection as the discharge. This ensures that air is removed from the flush line with the flush area completely flooded (Figure 16). Flush flow rate should be 1/4 GPM (30 psi max pressure). For high temperature applications flush flow may be increased to remove excess heat.

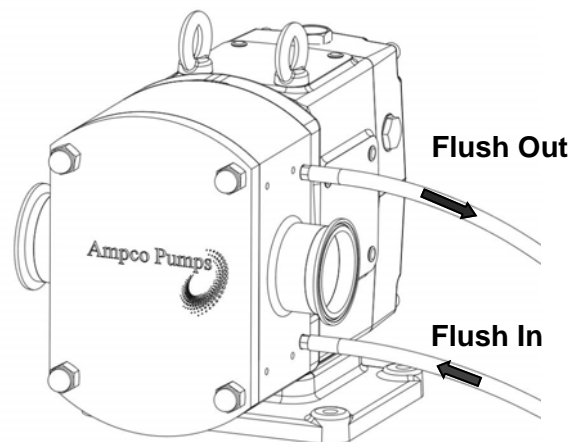

Figure 16: Proper Flushing for AL Double Seal

Maintenance



WARNING: Before attempting service on the pump or motor, DISCONNECT the power source to the pump. This will help prevent accidental start-up and serious injury.

The Ampco AL pump is designed to be easily disassembled for cleaning and maintenance purposes. When performing maintenance on the pump it is important to inspect all wetted parts for standard wear and damage. For inspection instructions please see page 13. Prior to disconnecting the pump, shut off all inlet and discharge valves, drain the pump (rinse if necessary), and turn off all electrical supply to the pump (follow standard lock out procedures).

Pump Lubrication

Proper lubrication of gears and bearings is vital to the life of the pump. For pumps assembled on bases with a gear reducer and motor, please refer to the proper manufacturer manual for lubrication requirements. These manuals are sent with the pump from the factory. Important lubrication points can be seen in Figure 17.

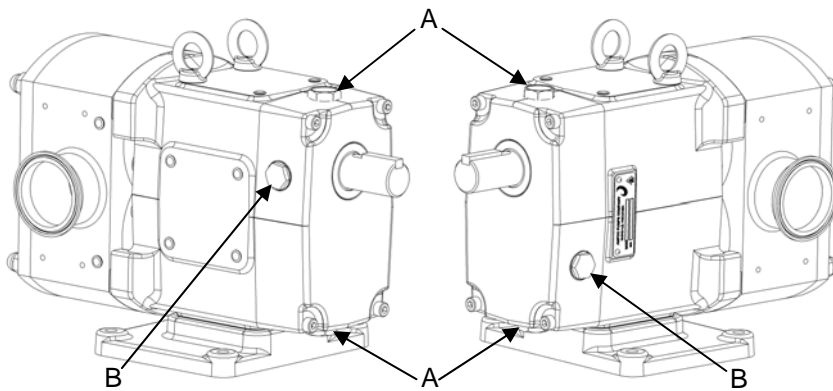

	Part	Qty.
A	Oil Plug (Drain and Fill)	2
B	Sight glass	2

Figure 17: Lubrication Points

The gears and bearings are shipped factory-lubricated with the gear case filled to proper oil capacity. The oil used to lubricate the gears should be changed every 500 hours with the quantities shown in Table 2. Correct oil quantity can easily be achieved by filling the gear case with oil to half way up the sight glass (Figure 18). Oil specification can be found below.

Table 2: Oil Capacity

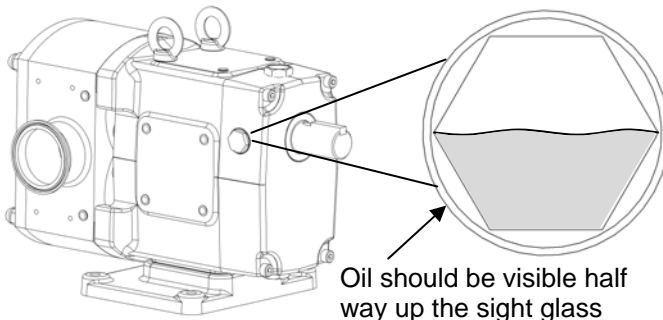

AL Model	Top/Bottom Shaft	Side Mount
5,10,15,20	~16 oz.	3.3 oz.
22, 25	~48 oz.	4.0 oz.
33, 34	~128 oz.	9.5 oz.
44, 46	~264 oz.	9.5 oz.

Oil Specifications:

ISO Grade 150 or SAE 40

*Replacement oil and grease is available from Ampco

*Note: Use oil amounts from the chart on the right

Figure 18: Sight Glass

Preventive Maintenance/ Inspection

While performing standard maintenance or cleaning, check for signs of damage or extreme wear. A simple inspection may show signs of a problem long before it becomes serious. Detection of such problems can avoid costly repairs and reduce down time. Remove the cover and inspect the rotor tips to ensure that there is no metal-to-metal contact between the rotors. Measure the clearance between the rotor tips as seen in Figure 19. The clearance should be equal on both sides. If contact is detected, rotors may require replacement.

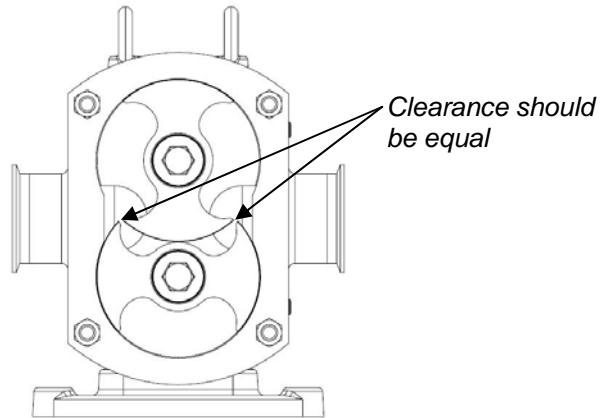

Figure 19: Clearance Between Rotor Tips

Inspect the shaft shoulder and splines (Figure 20) for wear and replace, if necessary.

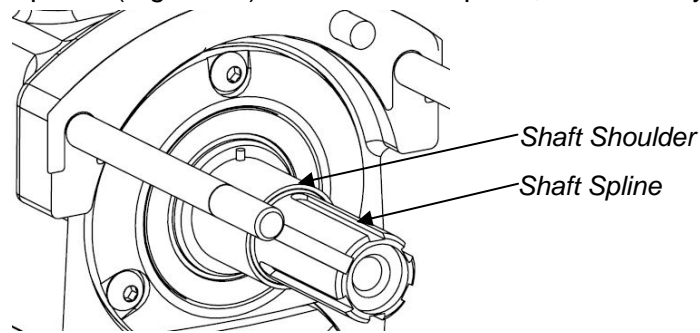

Figure 20: Shaft Inspection Points

Inspect the rotor hub (Figure 21) for wear and replace, if necessary. Rotor and shaft wear at these locations is caused by extended operation with loose rotor nuts.

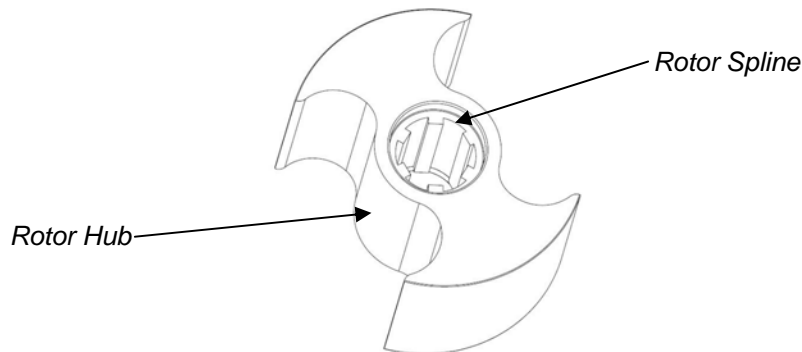

Figure 21: Rotor Inspection Points

Gear and Bearing Inspection

While the fluid end is disassembled, feel for gear backlash (movement between the gears) by rotating either shaft. Once turning has started the other shaft must engage (Figure 22). If gear backlash is present remove the gear casing cover (drain oil first, see page 24 for gear case disassembly information) and check for wear around the gear teeth. If evidence of gear teeth wear is present, replacement is recommended. If gear(s) are loose, check the shaft key and keyway, either may require replacement.

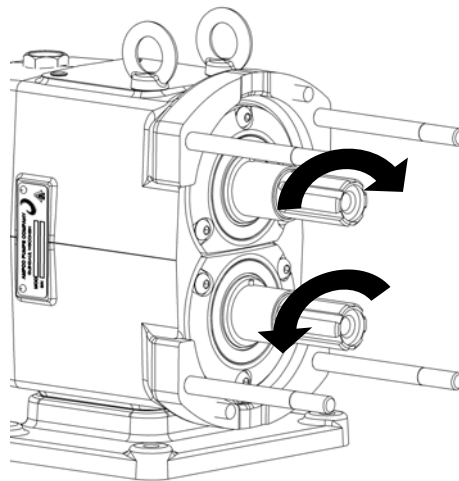

Figure 22: Check for Gear Backlash

Next, check the condition of the bearings. Do this by applying force in an up and down motion by hand on both shafts (Figure 23). Also check for any horizontal movement by pushing and pulling on the shaft. If any movement is felt the bearing may need replacing. If disassembly of the entire gear case is required, please refer to page 24 for instructions.

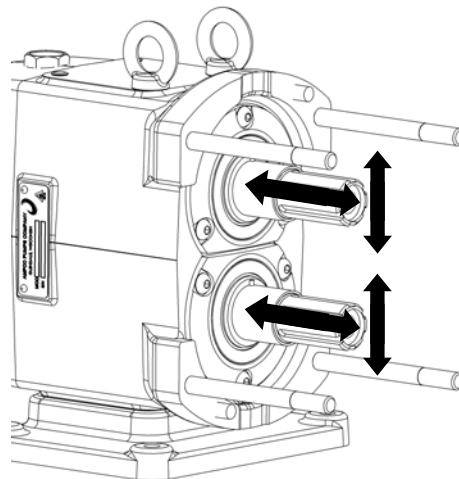

Figure 23: Check for Bearing Movement

Annual Maintenance

It is important to perform an annual maintenance check of the pump in addition to the preventative maintenance procedures listed on pages 13 and 14. Annual maintenance practices are as follows:

- Check the gear case bearings by measuring the shaft's radial movement with a dial indicator (Figure 24, A). If the movement is greater than or equal to the rotor-to-body clearances found on page 33 (Table 4) the bearings should be replaced.
- Remove the gear casing cover (See page 24 for disassembly information) and inspect the gears for wear and damage (Figure 24, B). Also check for backlash and looseness.
- Inspect the rotors for signs of wear and stress cracks around the areas defined in Figure 24, C. Replace, if necessary.
- Check the pump clearances detailed on page 33 to determine pump wear. Pump wear can be compensated by increasing pump speed.

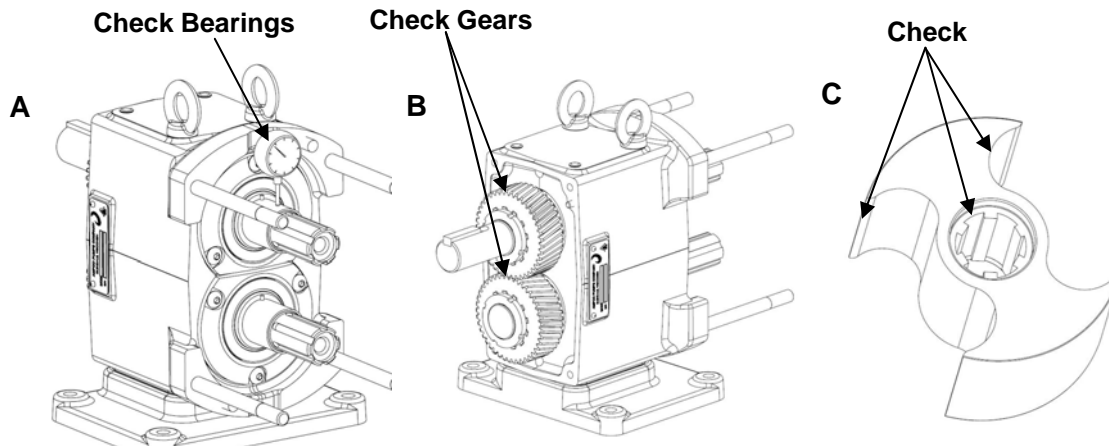

Figure 24: Annual Maintenance Checks

Cleaning

All wetted parts are designed and manufactured to be acceptable by 3A Sanitary Standards. The body, rotors, and seals can be easily disassembled and cleaned simply by removing the cover and rotor nuts. Pump disassembly information begins on page 16.

AL series pumps are designed for clean-in-place (CIP) capabilities ensuring that CIP solution reaches all surfaces inside the pump. The fluid velocity (typically 5 ft./sec) and differential pressure (30 psi recommended) are critical components of a correct CIP setup. For additional support, please contact the Engineering Department at Ampco Pumps Company (414-643-1852).

If for any reason the rotor o-ring should fail and the external threads of the rotor nut become soiled, a soft bristle brush and appropriate cleaning solution should be used to clean them. Do not use abrasive cleaning tools and chemicals. Wire brushes or pads will physically damage metal and seal parts. Pump parts should not be exposed to harsh acids for longer than necessary. Acids and cleaning solutions can be harmful. Take necessary steps to prevent bodily harm.

Pump Disassembly



WARNING: Before servicing the pump or motor, DISCONNECT the power source to the pump. This will help prevent accidental start-up and serious injury.

Caution: SHUT OFF product supply to the pump and drain the pump before disconnecting piping and disassembly.

1) Start by removing the cover nuts using an appropriate wrench (Figure 25). During disassembly place all parts on a clean, protected surface with finished surfaces and seal faces facing up. Tap the cover off using a soft mallet. Remove the cover o-ring and inspect.

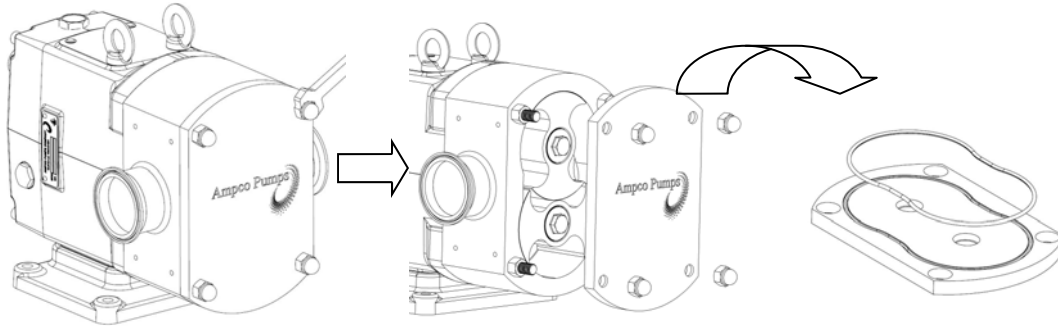

Figure 25: Removing AL Cover

2) Remove the rotor bolts using the appropriate size wrench and a non-metallic wedge to keep the rotors from moving (Figure 26). Remove the rotor bolt o-ring and lock washers.

3) Remove the rotors by orientating them perpendicular to each other and then pulling them out. It is important to be cautious with the rotors so that they are not damaged. For mechanical seals, the rotating seal typically stays in the rotor during removal (use caution). If rotors are difficult to remove, use a nylon or wood lever to pry them out without damaging the body or the rotors. If necessary, remove the body hold down nuts and tap the body forward to loosen the rotors. Use Figure 27 to ensure that all parts are removed.

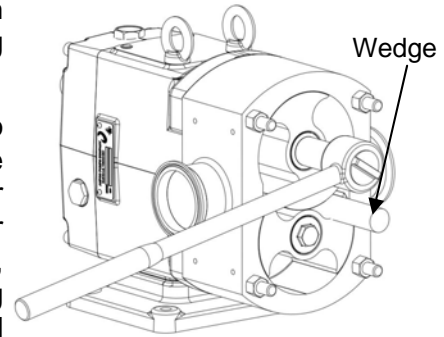
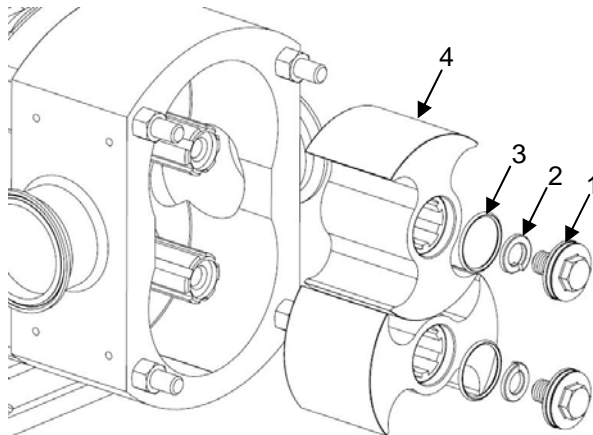

Figure 26: Removing Rotor Nuts



	Part
1	Rotor Bolt
2	Lock Washer
3	Rotor Bolt O-ring
4	AL Rotor

Figure 27: Fluid End Exploded View

Pump Disassembly

4) Remove the four body hold down nuts using the appropriate wrench. Pull the pump body off by sliding it along the studs (Figure 28). If the body is stuck, use a soft mallet to tap the body. Inspect the body for excessive wear, clean, and continue on to seal maintenance. It is important to keep track of the top and bottom shims and which shafts they are associated with. They are installed accordingly at the factory for that particular body.

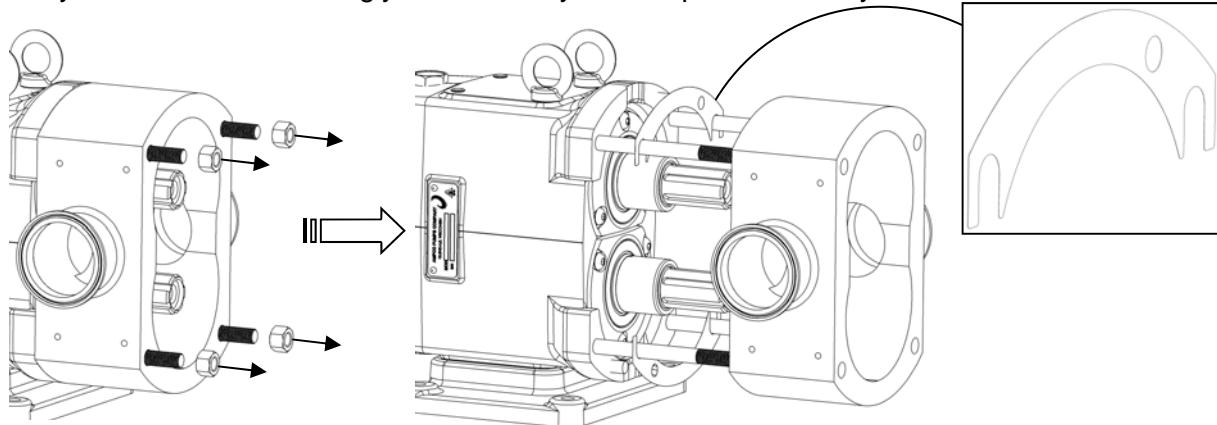

Figure 28: Removal of Pump Body

Seal Maintenance

Single O-Ring Seal

Disassembly: The single o-ring seal option is shown in Figure 29. Remove the body and rotor o-rings using the tool provided by Ampco (If damaged, replace o-rings). Slide the shaft sleeves off the shafts and inspect for damage. Do not re-use sleeves that are damaged (sleeve surface grooved or scratched).

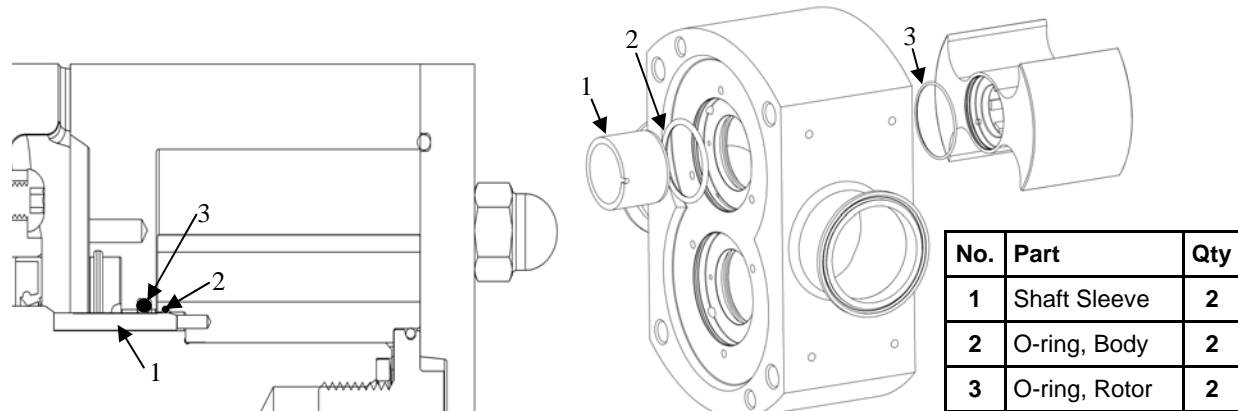

Figure 29: Single O-ring Seal

Seal Maintenance

Single O-Ring Seal, Continued

Assembly: Clean both shaft ends and the body before assembling. Slide the shaft sleeves onto the shafts until it seats on the shaft shoulder. Align the slot in the shaft sleeve to the drive pin on the shaft (Figure 30, A). Apply a light film of lubricant to NEW o-rings and insert them in the body and rotors (Figure 30, B). See Pump Assembly on page 31 to continue.

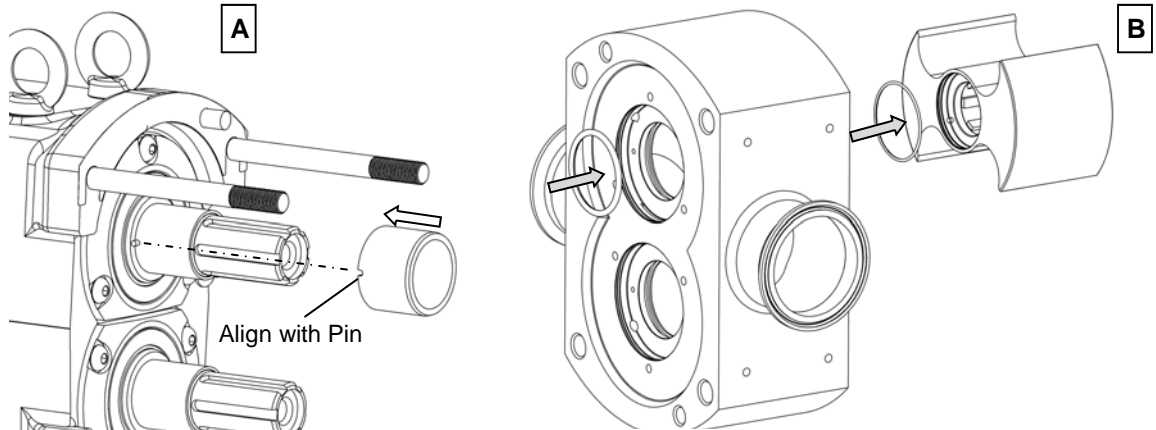

Figure 30: Single O-ring Seal Assembly

Double O-Ring Seal

Disassembly: The double o-ring seal option is shown in Figure 31. Remove the retaining bolts and washers using the appropriate driver and slide the o-ring carrier out of the body. Remove the o-rings from the body, o-ring carrier, and rotor (Figure 31, items 4, 5, 6). If damaged, replace o-rings. Slide the shaft sleeves off the shafts and inspect for damage. Do not re-use sleeves that are damaged (sleeve surface grooved or scratched).

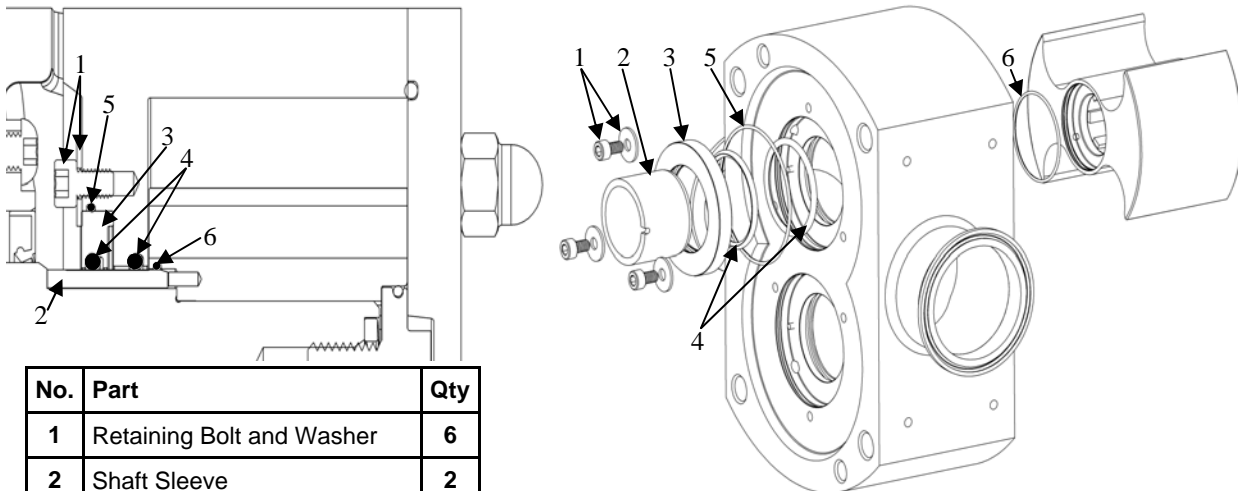

Figure 31: Double O-ring Seal

No.	Part	Qty
1	Retaining Bolt and Washer	6
2	Shaft Sleeve	2
3	O-ring Carrier	4
4	O-ring, Body	2
5	O-ring, O-ring Carrier	2
6	O-ring, Rotor	2

Seal Maintenance

Double O-Ring Seal, Continued

Assembly: Clean both shaft ends and the body before assembling. Slide the shaft sleeves onto the shafts until it seats on the shaft shoulder. Align the slot in the shaft sleeve to the drive pin on the shaft (Figure 32, A). Apply a light film of lubricant to NEW o-rings and insert them in the body, o-ring carriers, and rotors (Figure 32, B). Once all of the o-rings are installed slide the o-ring carriers into the body making sure to align the holes in the carriers to the pin in the body. The o-ring carrier should sit flush with the back of the body. Secure the carriers in place with the retaining bolts and washers. See Pump Assembly on page 31 to continue.

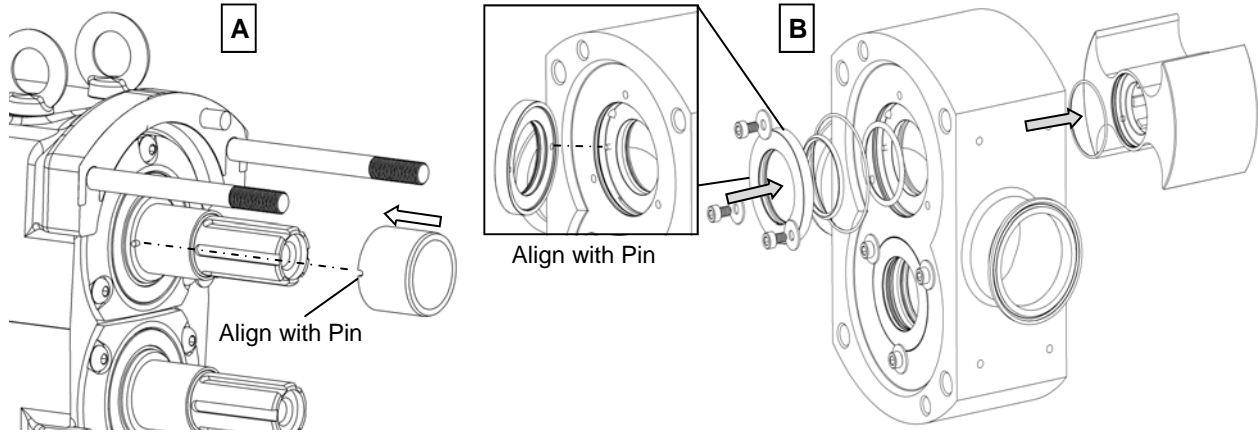
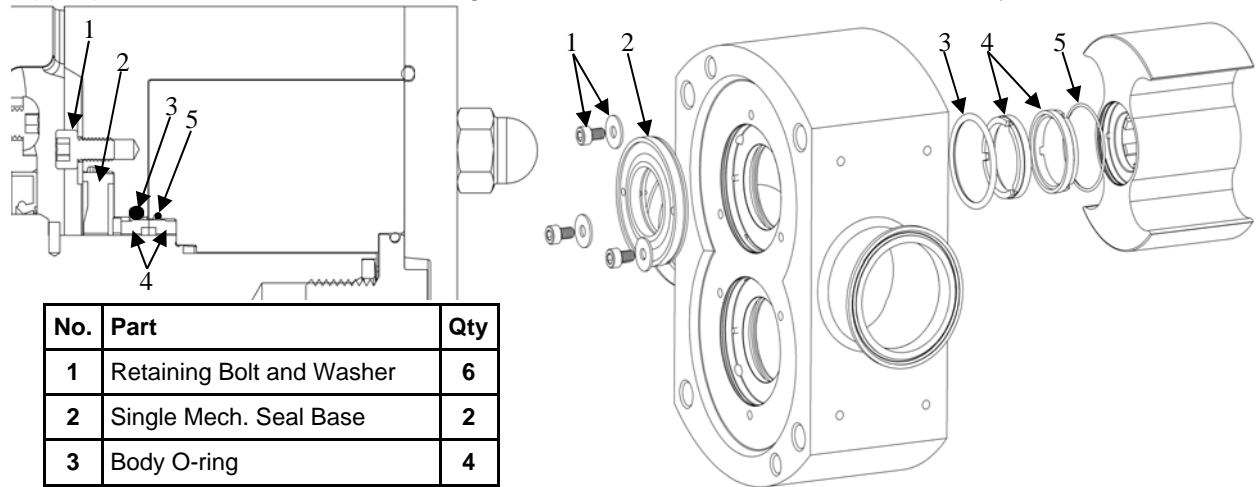

Figure 32: Double O-ring Seal Assembly

Single Mechanical Seal

Disassembly: The single mechanical seal option is shown in Figure 33. The AL single mechanical seal is designed to be front pull out without the need to remove the pump body. Using the o-ring tool provided by Ampco remove the mechanical seal from the rotor and body. Inspect the seals for chipping, scratches, or any evidence of cracks on the seal face (the mechanical seals are interchangeable). Remove the o-rings from the body and rotor (Figure 31, items 3, 5). If damaged, replace o-rings. If any of the seals are damaged do not re-use them. To remove the mechanical seal base loosen the retaining bolts and washers using the appropriate driver and slide the single mechanical seal bases out of the body.



No.	Part	Qty
1	Retaining Bolt and Washer	6
2	Single Mech. Seal Base	2
3	Body O-ring	4
4	Mechanical Seal	2
5	Rotor O-ring	2

Figure 33: Single Mechanical Seal

Seal Maintenance

Single Mechanical Seal, Continued

Assembly: Clean both shaft ends and the body before assembling. Slide the mechanical seal bases into the body and secure them with the retaining bolts and washers (Figure 34, A). Apply a light film of lubricant to NEW o-rings and insert them into the body (Figure 34, B) and rotors (Figure 34, C) along with the mechanical seal faces. Make sure to align the slot on the seal to the pins in the body and rotor. See Pump Assembly on page 31 to continue.

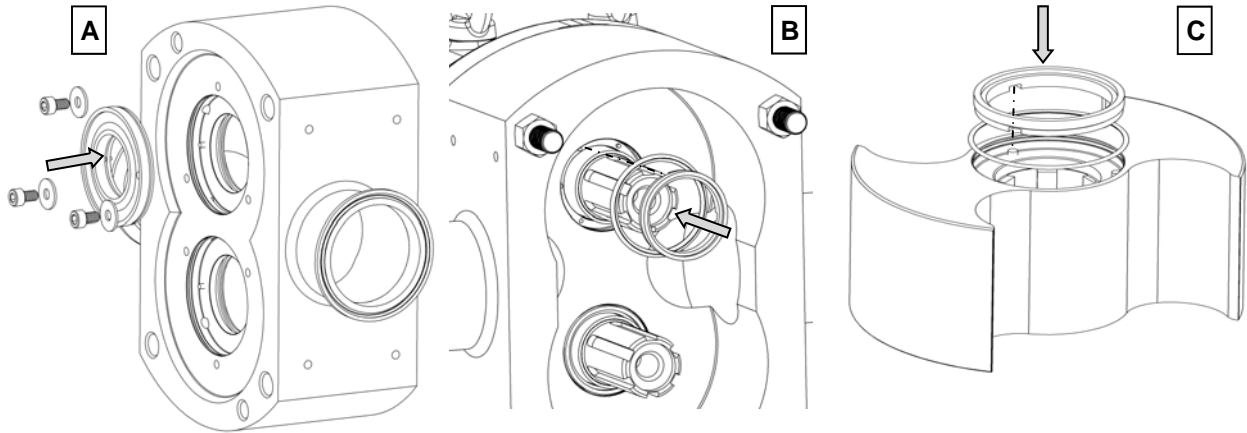
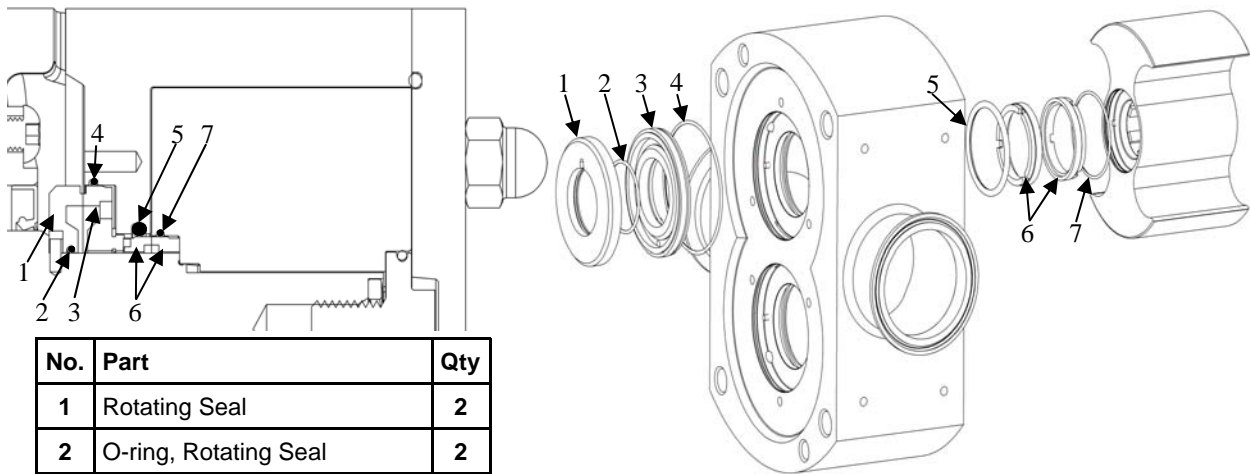

Figure 34: Single Mechanical Seal Assembly

Double Mechanical Seal

Disassembly: The double mechanical seal option is shown in Figure 35. Using the o-ring tool provided by Ampco remove the mechanical seal and o-rings from the rotor and body. Slide the double mechanical seal base out of the body and remove the seal base o-ring. Slide the rotating seal from the shaft and remove the rotating seal o-ring. Inspect the seals for chipping, scratches, or any evidence of cracks on the seal face. If damaged, replace o-rings. If any of the seals are damaged do not re-use them.



No.	Part	Qty
1	Rotating Seal	2
2	O-ring, Rotating Seal	2
3	Double Mech. Seal Base	4
4	O-ring, Seal Base	2
5	O-ring, Body	2
6	Mechanical Seal	2
7	O-ring, Rotor	2

Figure 35: Double Mechanical Seal

Seal Maintenance

Double Mechanical Seal, Continued

Assembly: Clean both shaft ends and the body before assembling. Lubricate the rotating seal o-ring and install it in the rotating seal. Slide the rotating seal onto the shaft as seen in Figure 36 (A) making sure to line the slot on the rotating seal to the pin in the shaft. Install the seal base o-ring in the back of the body and apply a light film of lubricate. Push the double mechanical seal base in the body making sure to line up the holes in the base with the pins in the body (Figure 36, B).

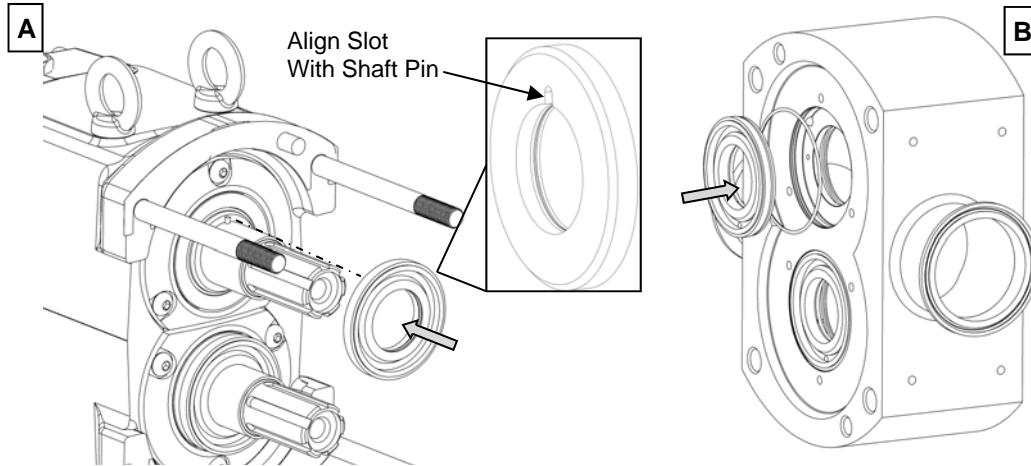

Figure 36: Double Mechanical Seal Assembly

Apply a light film of lubricant to the body o-rings and insert them in the body along with the mechanical seal (Figure 37, A). The mechanical seals in the product zone are interchangeable. Lubricate the rotor o-rings and insert them in the rotors along with the mechanical seals (Figure 37, C) . Make sure to align the slot on the seal to the pins in the body and rotor. See Pump Assembly on page 31 to continue.

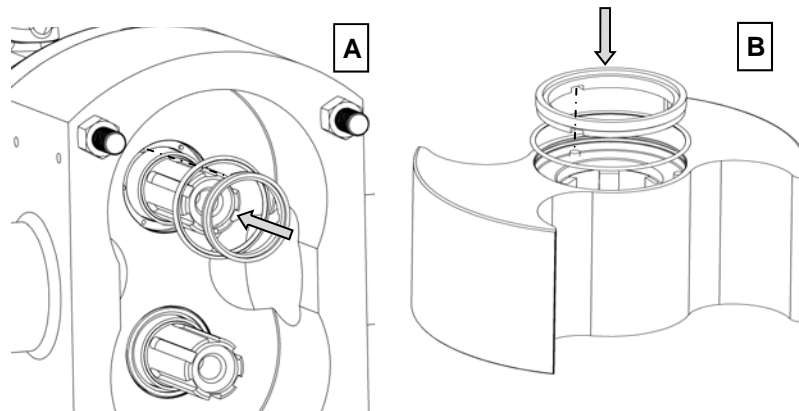
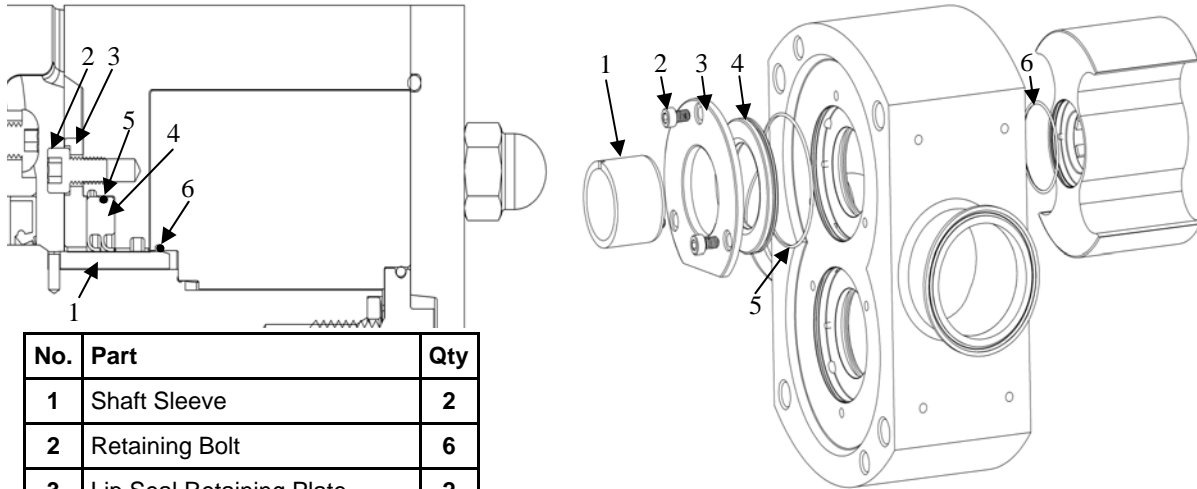

Figure 37: Double Mechanical Seal Assembly

Seal Maintenance

Lip Seal (Double or Triple)

Disassembly: The lip seal option is shown in Figure 38. Remove the retaining bolts using the appropriate driver and slide the lip seal out of the body. Check the lip seal for damage around the lips, if any of the lips are damaged discard the lip seal and replace it. Remove the o-rings from the lip seal and rotor (Figure 38, items 5, 6). If damaged, replace o-rings. Slide the shaft sleeves off the shafts and inspect for damage. Do not re-use sleeves that are damaged (sleeve surface grooved or scratched).



No.	Part	Qty
1	Shaft Sleeve	2
2	Retaining Bolt	6
3	Lip Seal Retaining Plate	2
4	Lip Seal (Double or Triple)	2
5	O-ring, Lip seal	2
6	O-ring, Rotor	2

Figure 38: Lip Seal (Double or Triple)

Assembly: Clean both shaft ends and the body before assembling. Slide the shaft sleeves onto the shafts until it seats on the shaft shoulder. Align the slot in the shaft sleeve to the drive pin on the shaft (Figure 39, A). Apply a light film of lubricant to the NEW o-rings and insert them on the lip seal and in the rotors (Figure 39, B). Once all of the o-rings are installed slide the lip seals into the body. Secure the lip seals in place with the retaining bolts. See Pump Assembly on page 31 to continue.

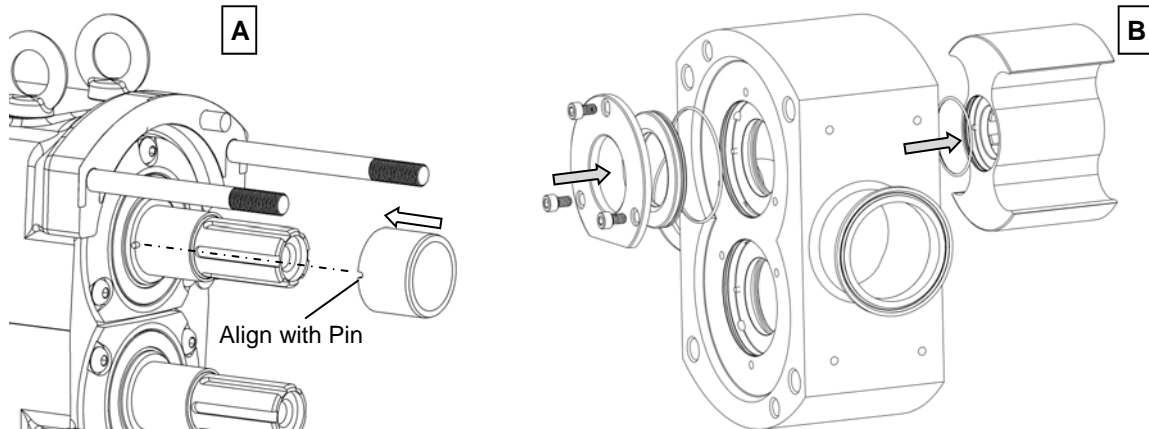
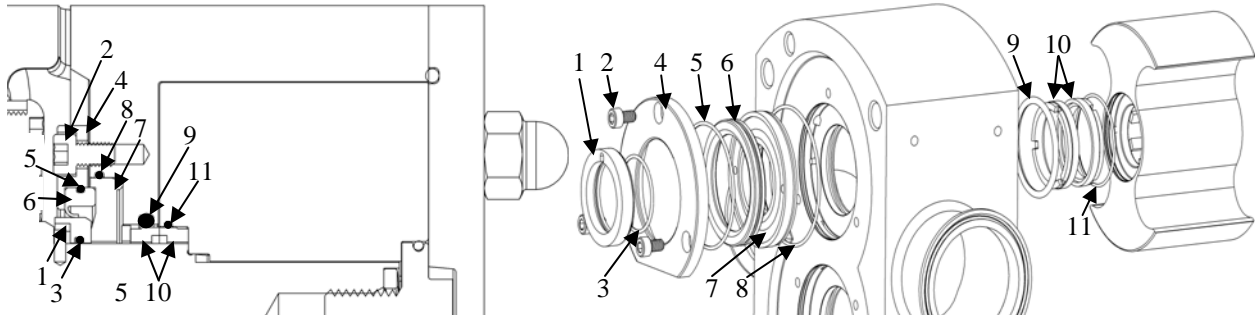

Figure 39: Lip Seal (Double or Triple) Assembly

Seal Maintenance

Mechanical Seal with Flush (Lip Seal)

Disassembly: The mechanical seal with flush option is shown in Figure 40. Remove the mechanical seals and o-rings from the rotor and body. Remove the retaining bolts using the appropriate driver and slide the retaining plate, lip seal, and mechanical seal base out of the body. Check the lip seal for damage around the lip and replace if damaged. Slide the ceramic flush sleeve from the shaft and inspect for damage. Do not re-use sleeves that are damaged (sleeve surface grooved or scratched). Remove the o-rings from all components (Figure 40, items 3, 5, 8, 9, 11). If damaged, replace o-rings.



No.	Part	Qty	No.	Part	Qty
1	Ceramic Flush Sleeve	2	7	Mechanical Seal Base	2
2	Retaining Bolt	6	8	O-ring, Seal Base	2
3	O-ring, Flush Sleeve	2	9	O-ring, Body	2
4	Lip Seal Retaining Plate	2	10	Mechanical Seal	4
5	O-ring, Lip Seal	2	11	O-ring, Rotor	
6	Flush Lip Seal (Single)	2			

Figure 40: Mechanical Seal with Flush (Lip Seal)

Assembly: Apply a light film of lubricant to the o-rings and insert them into all components. Slide the ceramic flush sleeve on the shaft until it seats on the shaft shoulder. Align the slot in the sleeve to the drive pin on the shaft (Figure 41, A). Slide the mechanical seal bases and lip seals into the body and secure them with the retaining plate and bolts. Install the mechanical seals in the body and rotors being sure to align the slot on the seals with the pins in the rotor and seal base. See Pump Assembly on page 31 to continue.

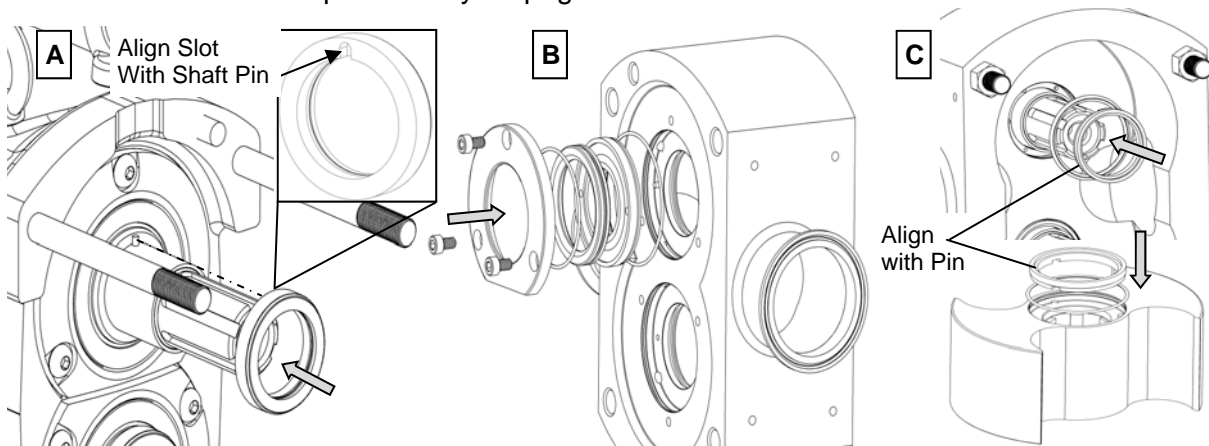

Figure 41: Mechanical Seal with Flush (Lip Seal) Assembly

Gear Case Maintenance



WARNING: Before servicing pump or motor, DISCONNECT the power source to the pump. This will prevent accidental start-up and serious injury.
CAUTION: SHUT OFF product supply to the pump and drain the pump before disconnecting piping and disassembly.

Disassembly

1) Remove the pump head as described on page 16 (Pump Disassembly). Remove the bottom oil plug and drain the oil from the gear case (remove oil fill plug for faster drain). Remove the four socket head cap screws from the gear case cover and slide the cover off the drive shaft (Figure 42). If the cover is stuck, use a soft mallet to tap around the edges until it breaks free. Using a straight edge remove the liquid gasket used to seal the cover to the gear case. Remove and discard the oil seal from the cover using an arbor press.

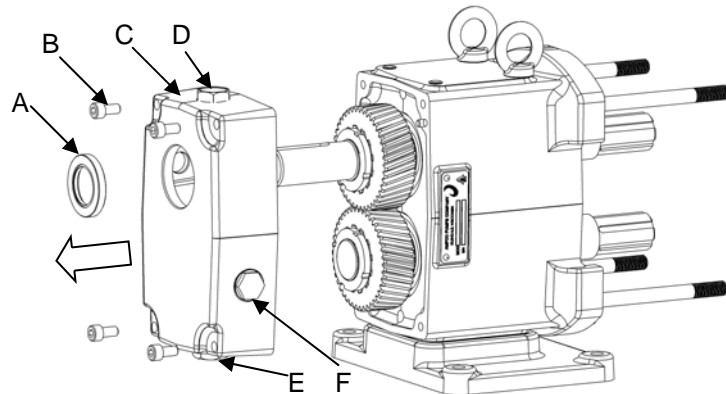

	Part
A	Oil Seal
B	Socket Head Cap Screws
C	Gear Case Cover
D	Oil Plug (Fill)
E	Oil Plug (Drain)
F	Sight Glass

Figure 42: Gear Case Disassembly (Gear Case Cover)

2) Using a hammer and a punch, bend the tabs straight on the lock washers (Figure 43). Use a wedge (wood or plastic) to keep the shafts from turning while removing the lock nuts (Figure 44). Using a spanner wrench or punch, remove the gear lock nuts. Slowly remove the gears from the shafts. Remove the gear keys and gear spacers from the shafts.

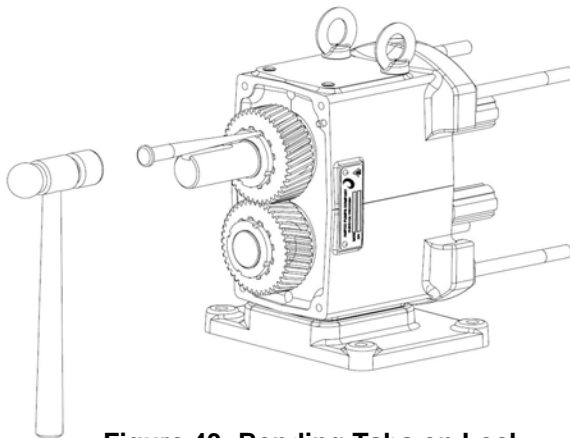

Figure 43: Bending Tabs on Lock Washers

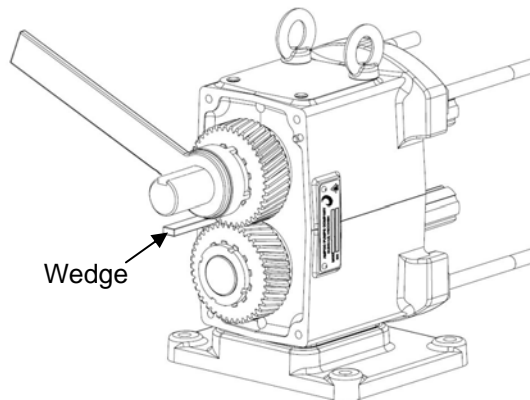

Figure 44: Removing Lock Washers

Gear Case Maintenance

3) To prevent damage to the shafts, wrap the shaft splines with electrical tape (Figure 45, A). Any damage to the shaft splines may require the shaft to be replaced. Remove the screws holding the bearing retainers in place and slide both bearing retainers off the shaft (Figure 45, B). If they are stuck, use a flat head screw driver as a wedge to pry them from the gear case or leave them in place and when the shafts are removed they will press off with the shafts. Remove the o-rings from the bearing retainers and replace if damaged.

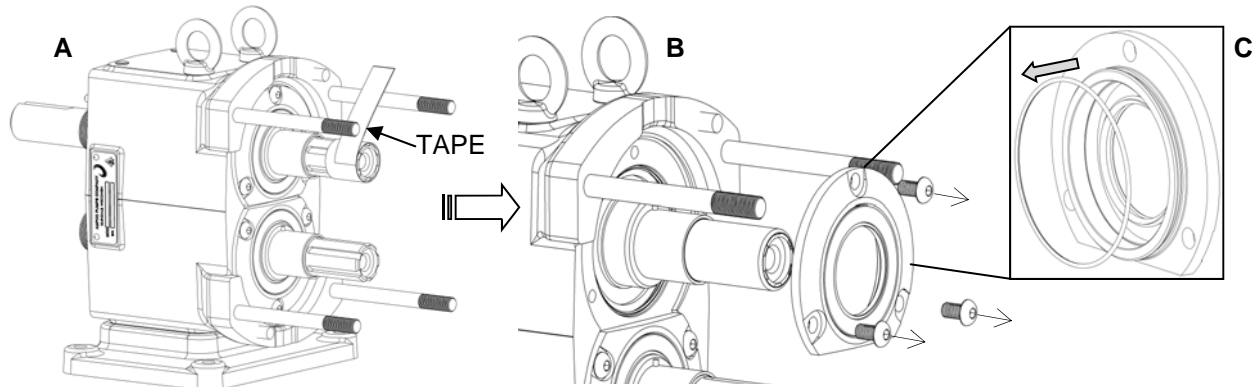

Figure 45: Tape Shafts and Remove Bearing Retainers

4) Remove the gear case studs and set the gear case in a press with the fluid end side facing down (Figure 46). Use a wooden block to protect the shafts from hitting the ground when pushed out. Once the protective block is in place, push the shafts out of the gear case.

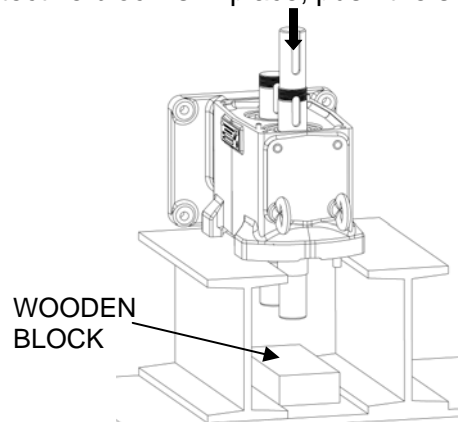

Figure 46: Pressing Shafts From Gear Case

5) Remove and discard the front bearing seals from the bearing retainers by pressing them out (Figure 47). Clean the bearing retainers as they will be reused.

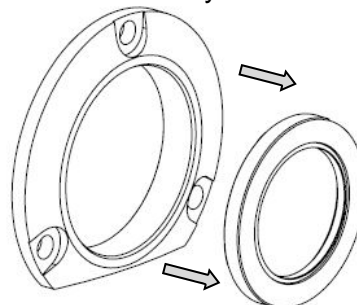

Figure 47: Removing Oil Seals

Gear Case Maintenance

6) Using a press and equally sized blocks, remove the front and rear bearings along with the bearing spacer. To prevent damage to the shafts make sure that both ends are protected (Figure 48). The bearings are press fit on the shaft and will require a press to be removed.

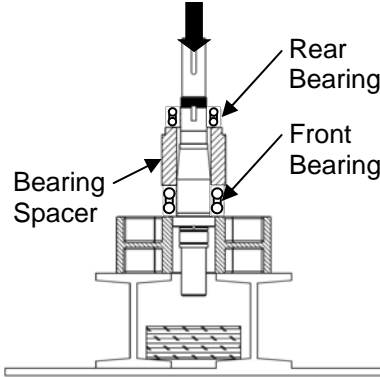

Figure 48: Removing Bearings and Sleeve From Shaft

Assembly

1) Clean all reusable parts prior to reassembly. Apply a light coat of lubricant on the shaft area where the front bearing will sit. Position the shaft upright in the press with the rotor end facing down (Figure 49, A). Ball bearings are used on all models except for the AL40 series. For the AL40 series it is important to not interchange any parts of the bearing assembly since all bearings are manufactured as sets and assembled to have a precise overall length. Open the new front bearings and place it over the shaft along with the bearing spacer (Figure 49, B). Make sure the bearing and spacer are aligned before pressing them on. Using a sleeve that rests on the bearing spacer and rides over the shaft, press the bearing on until it seats against the shaft shoulder. A shim can be used to ensure that the bearing is fully rested on the shaft shoulder (Figure 49, C).

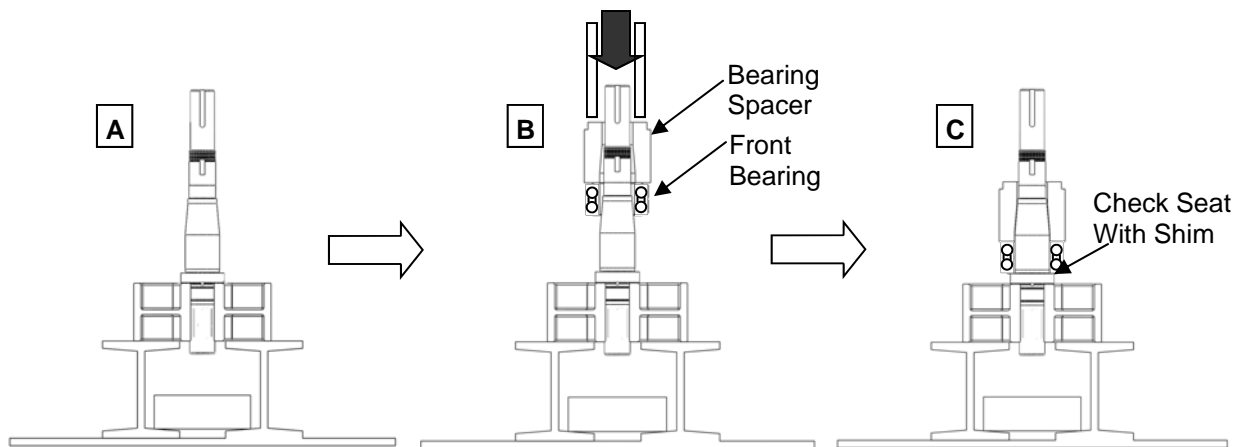

Figure 49: Pressing Front Bearing onto Shaft

Gear Case Maintenance

2) Apply a light coat of lubricant on the shaft. Open the new rear bearing and place it over the shaft above the bearing spacer (Figure 50, A). Using a sleeve that rests on the bearing's inner race and over the shaft, press the bearing on until it seats against the bearing spacer. For the AL40 series it is important to keep all assemblies together as they come packaged. Make sure the bearing is rested on the bearing spacer using a shim (Figure 50, B).

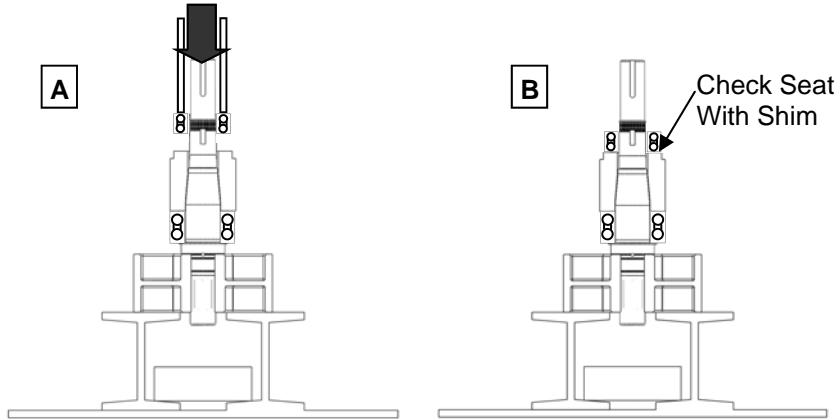

Figure 50: Pressing Rear Bearing onto Shaft

3) Set the gear case on a press with the fluid end side facing up. Apply lubricant to the outside of the bearings. Place shaft assembly (one shaft at a time) in the gear case with the rotor end facing up. Making sure that the drive and the short shafts are in the correct bores, press the shafts into the gear case until bearings are fully seated (Figure 51).

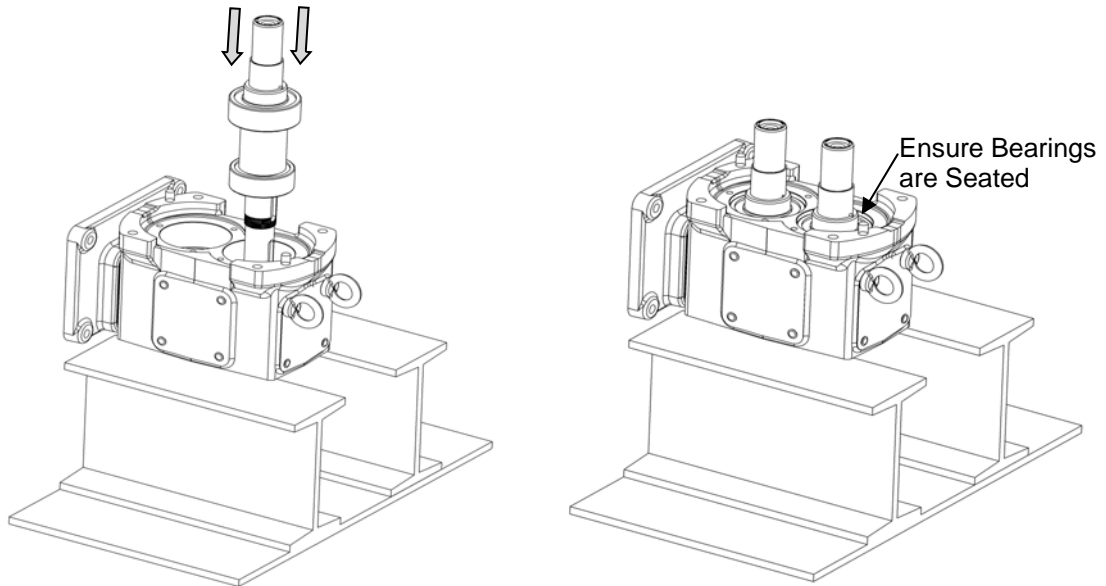

Figure 51: Pressing Rear Bearing onto Shaft

Gear Case Maintenance

4) Press new oil seals into the bearing retainers making sure the top of the seal is flush with the top of the retainer (Figure 52,A). Apply a light film of lubricant to the new bearing retainer o-rings and install them to the bearing retainers (Figure 52,B). After lubricating the lip of the oil seal slide them over the shafts and fasten them to the gear case using the retaining screws.

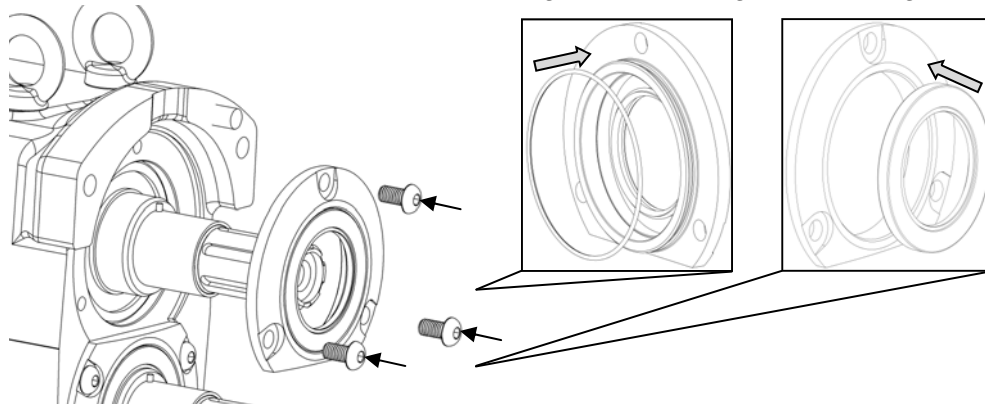

Figure 52: Bearing Retainer Installation

5) Thread the gear case studs into the front of the gear case as shown in Figure 53. Install the stud short side in.

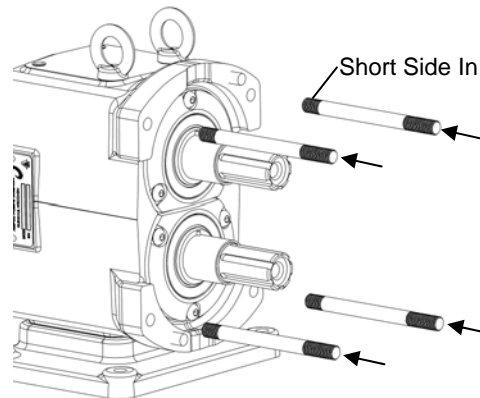

Figure 53: Gear Case Stud Installation

6) Align the shafts so that the gear key slots are pointing up. Slide the gear spacers on the shafts and insert the gear keys in the key slots (Figure 54).

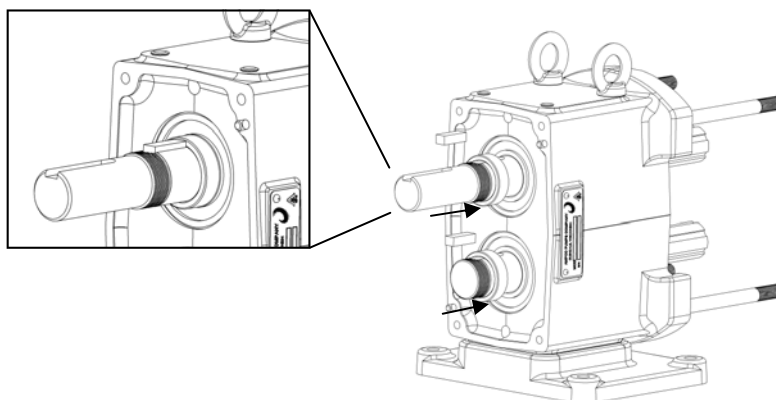

Figure 54: Gear Spacer and Key Installation

Gear Case Maintenance

7) In order to ensure proper rotor timing the gears must be installed along with the rotors. Slide the gears on the shafts, aligning the slot on the gear with the gear key (Figure 55, A). Secure them in place using the gear lock nuts making sure that the dots on the gears line up (Figure 55, B).

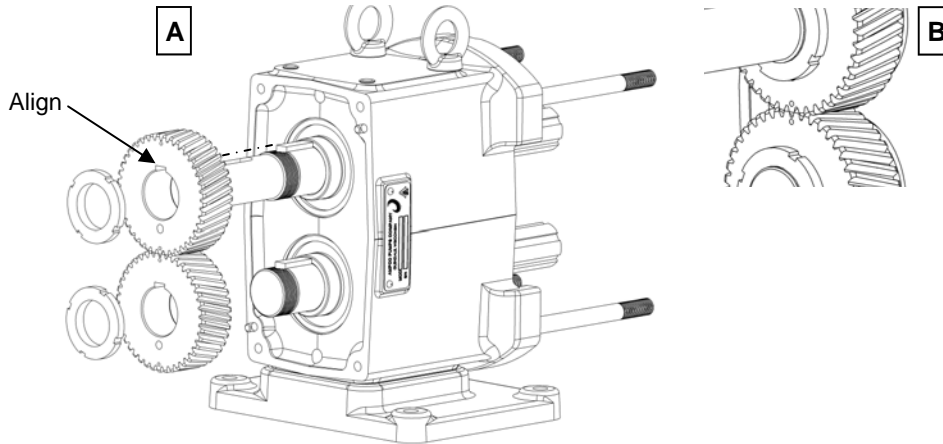

Figure 55: Installing Gears to Check Timing

8) Rotor timing is critical for the proper pump operation. Once the gears are locked in place install the rotors to the bare shafts and secure them with the rotor screws. For bi-wing rotors the distance between the rotor tips should be equal (Figure 56, A). For tri-lobe rotors measure the clearance between the lobes (Figure 56, B and C). Correct rotor clearance can be found on page 33. If the clearances are incorrect proceed to step 9, otherwise skip to step 10.

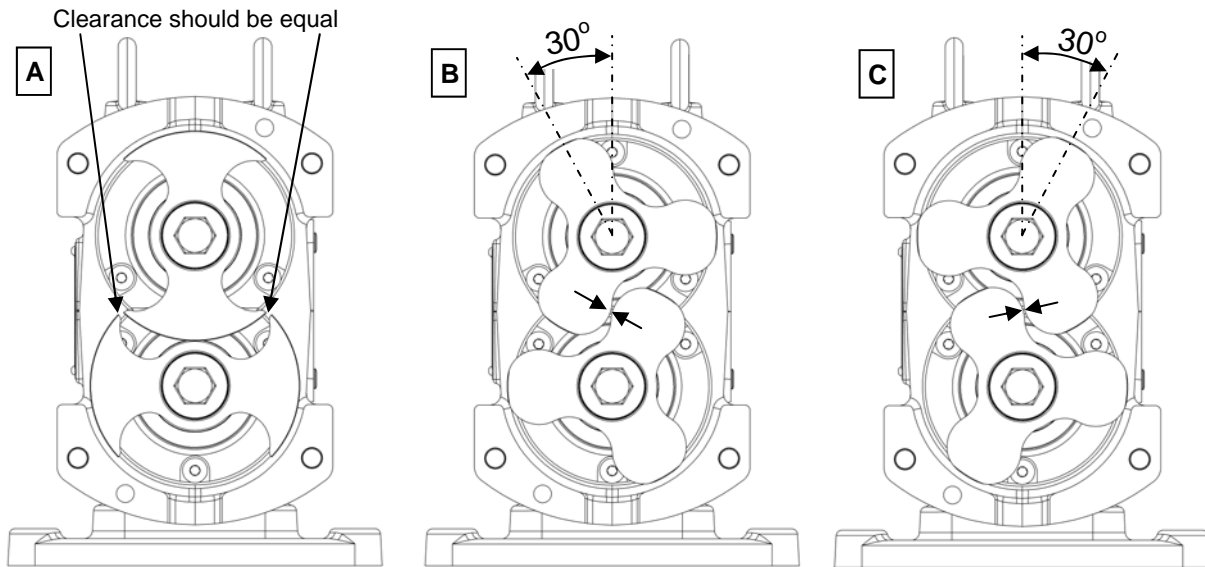

Figure 56: Checking Rotor Timing

Gear Case Maintenance

9) If the clearances are incorrect they can be adjusted by shimming one gear. Remove the gear lock nuts and gears, and add gear shims to one shaft (Figure 57). The gear being shimmed is determined after checking the clearances, some trial and error may be necessary. Once the shims are in place reassemble the gears and ensure the correct clearances are met. Remove the rotors from the shafts.

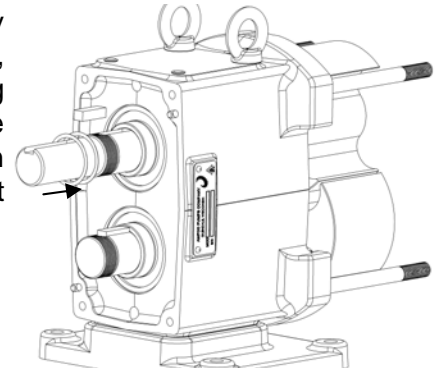

Figure 57: Gear Shim Installation

10) With the gears on the shafts, slide the lock washer on the shaft (Figure 58, A). Align the tab inside the lock washer with the hole on the gear (Figure 58, B).

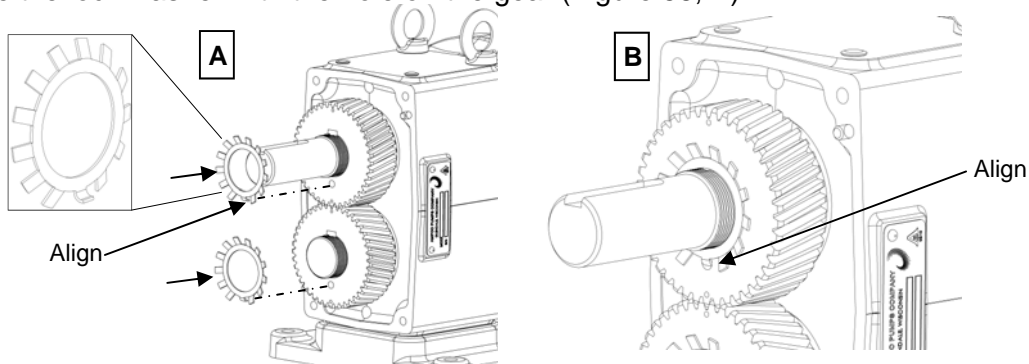

Figure 58: Lock Washer Installation

11) Lubricate the threads of the lock nuts and thread them on the shafts (Figure 59 A). Using a spanner wrench, tighten them to the specified torque in Table 3. Use a wedge (wood or plastic) between the gear teeth to keep the shafts from turning while tightening the lock nuts (Figure 59, B). Secure the nut in place by bending the locking tabs on the lock washer into the lock nut slots (Figure 59, C).

Table 3: Recommended Lock Nut Torque Values

AL Model	ft-lbs	N-m
05, 10, 15, 20	75	102
22, 25	100	136
33, 34	140	190
44, 46	230	312

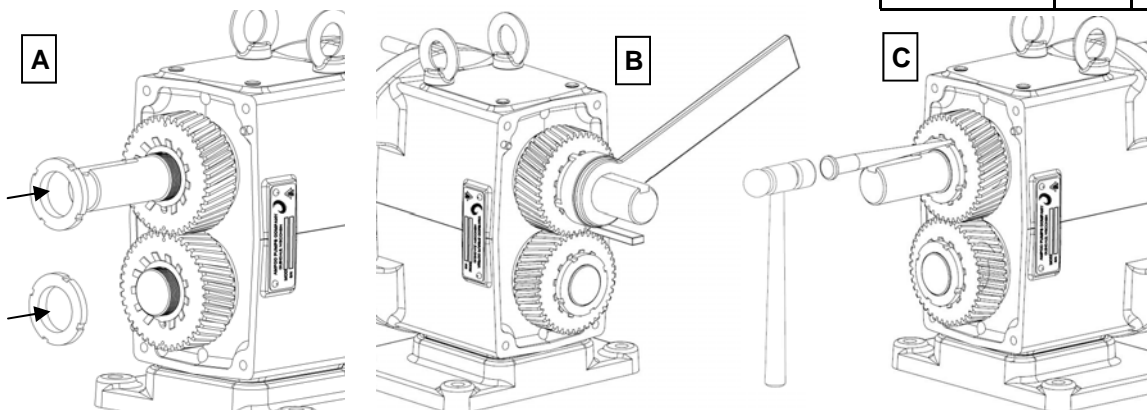

Figure 59: Gear Installation

Gear Case Maintenance

12) Press the new oil seal into the gear case cover so the seal is flush with the outside of the cover and so that the spring will face the gears (Figure 60, A). Apply a silicone sealant to the edges on the back of the gear case making sure there are no gaps (Figure 60, C). Wrap the shaft keyway with tape to avoid cutting the lip seal on the shaft keyway. Apply a light film of lubricant to the inside and outside diameters of the gear case cover oil seal. Slide the back cover onto the gear case, and secure it with the retaining bolts (Figure 60, B). Install the oil plugs and fill the gear case with the recommended amount of oil using Table 2 on page 12.

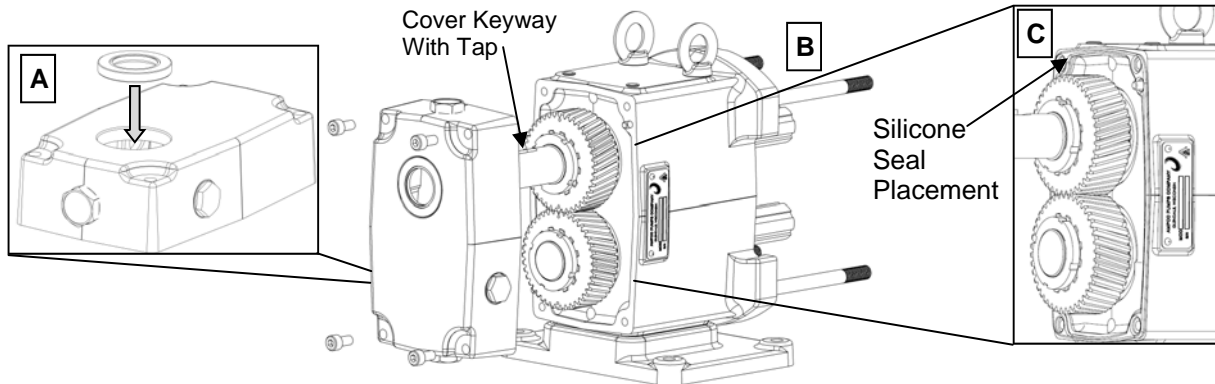

Figure 60: Gear Case Cover Assembly

Pump Assembly

1) Make sure all seal components are installed by following the “Seal Assembly” instructions on page 17. Ensure all dowels are in place and that all parts including body, rotors, and rotor nuts are clean and free of foreign matter. Install the correct shims on the gear case, using grease to hold them in place, if needed. Slowly slide the body over the gear case studs and shafts, ensuring the seals are kept in place and not damaged (Figure 61, A). Install the four hold down nuts and tighten the body against the gear case to ensure the dowels are engaged (Figure 61, B). Rotate the shafts to make sure there is no interference with the seals. Ensure that the shims have not fallen out.

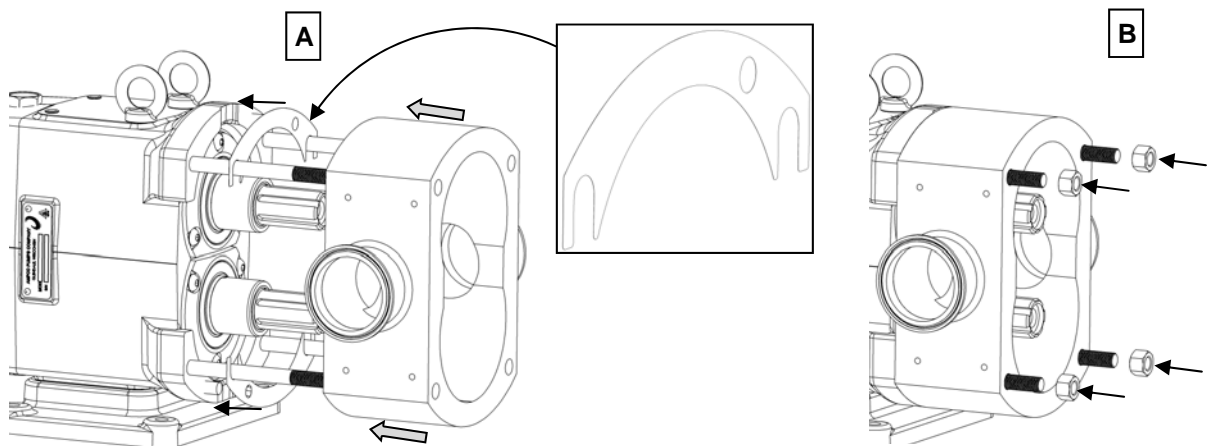

Figure 61: Installing Shims and Pump Body

Pump Assembly

2) Align the short spline in the rotor with the short spline on the shaft and slide the rotor on the shaft (Figure 62, A). Install a new rotor bolt o-ring in the o-ring groove on the rotor bolt. Slide the lock washer on the rotor bolt and thread the rotor bolt into the shaft, tightening it down using the appropriate wrench and a non-metallic wedge to hold the rotor in place (Figure 62, B). See Table 4 for required torque values. Repeat with the second rotor.

Table 4: Recommended Rotor Bolt Torque Values

AL Model	ft-lbs	N-m
05, 10, 15, 20	20	27
22, 25	32	43
33, 34	47	64
44, 46	65	88

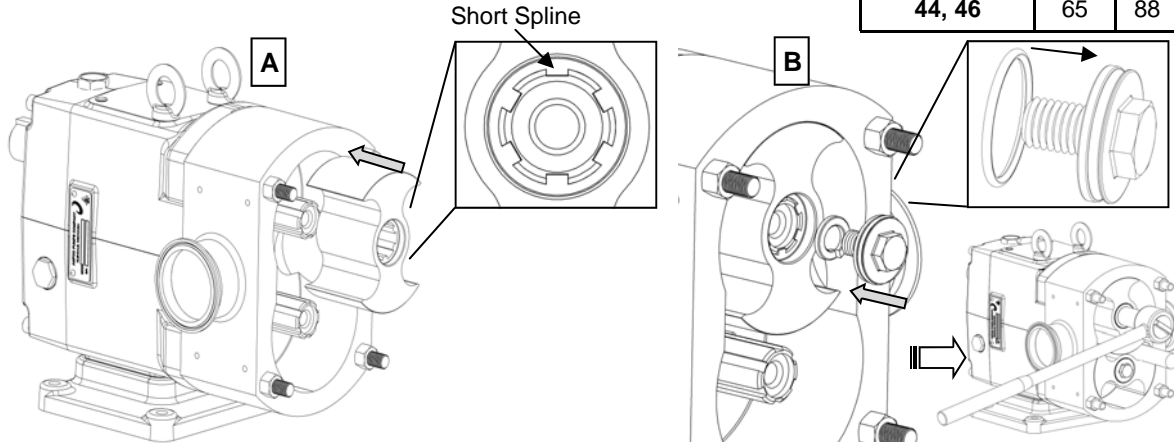

Figure 62: Rotor Installation

2) Install the new cover o-ring and slide the cover over the studs (Figure 63, A). Visually inspect to ensure that the cover o-ring remained in place. Using an appropriate wrench, thread the cover nuts on the studs and tighten them in an opposing manner as seen in Figure 65, so that the cover is evenly tightened to the body.

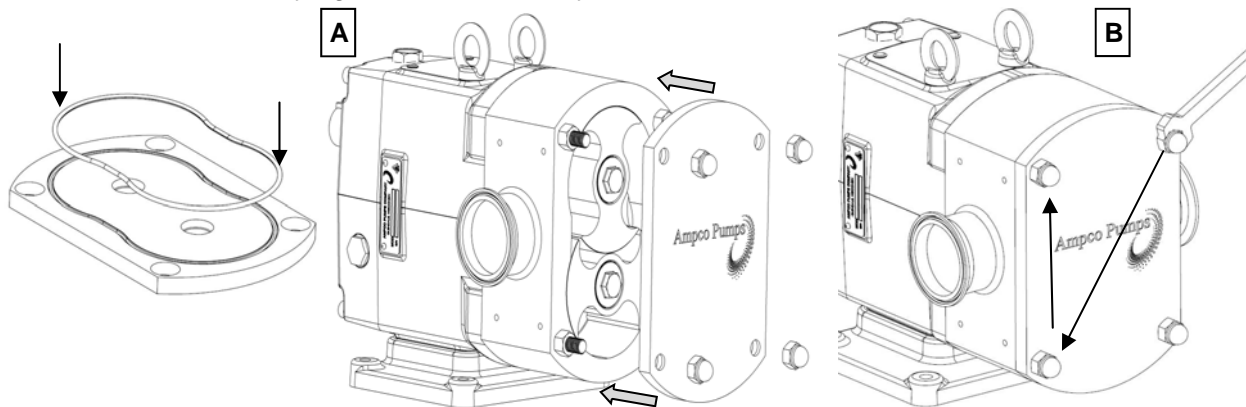

Figure 63: Cover Installation

Pump Clearances

The performance of an AL pump is based on the tight clearances between the pump body and the rotors. These clearances are critical to ensure the pump performs up to the system requirements. The backface clearances are set when the body is assembled to the gear case (page 31) using shims placed between the gear case and the front bearing. Other clearances are shown in Figure 64 and should be in accordance to Table 4. Use shims and a depth micrometer to measure the clearances.

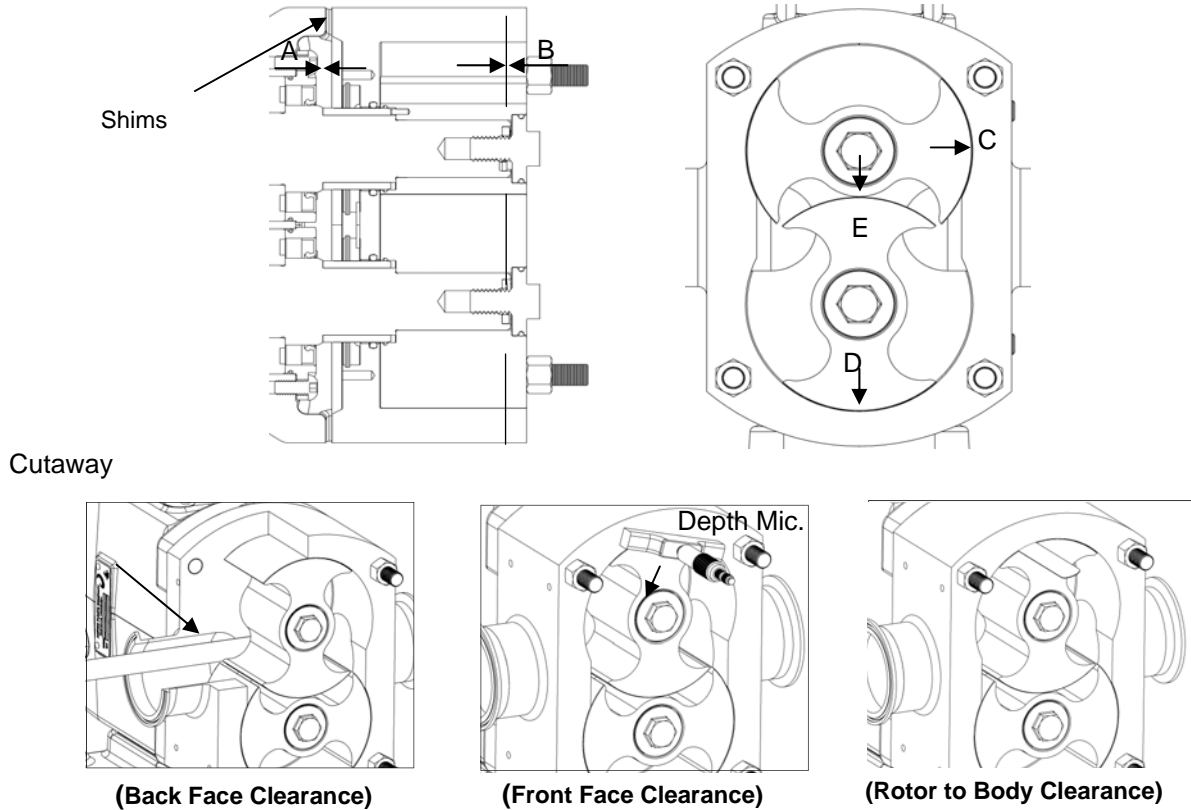

Figure 64: Critical Pump Clearances

Table 4: Critical Pump Clearance Dimensions (Standard Rotors)

AL Model	A (Backface)		B (Front Face)		C (Radial Sides)		D (Radial Top/Bottom)		E (Rotor to Rotor)	
	Inch	mm	Inch	mm	Inch	mm	Inch	mm	Inch	mm
5, 10	.006	.15	.006	.15	.006	.15	.005	.12	.005	.12
15	.006	.15	.006	.15	.011	.27	.005	.12	.006	.15
20	.006	.15	.006	.15	.012	.30	.006	.15	.006	.15
22	.008	.20	.008	.20	.012	.30	.006	.15	.008	.20
25	.008	.20	.008	.20	.016	.40	.008	.20	.008	.20
33	.012	.30	.012	.30	.016	.40	.008	.20	.012	.30
34	.012	.30	.012	.30	.020	.50	.012	.30	.012	.30
44	.018	.45	.018	.45	.022	.55	.012	.30	.016	.40
46	.018	.45	.018	.45	.028	.70	.018	.45	.016	.40

Ampco Pumps Available Options

Jacketed Cover and Casing

The jacketed cover and casing option (Figure 65) allows for heating or cooling fluid to be circulated around the pump's fluid end to match the demands of certain products. This fluid (media) can preheat or cool the product and sustain temperature during operation and short shut downs. The jacketed cover is not a heat exchanger and is not designed to primarily control the product temperature. Please contact Ampco Pumps for replacement information.

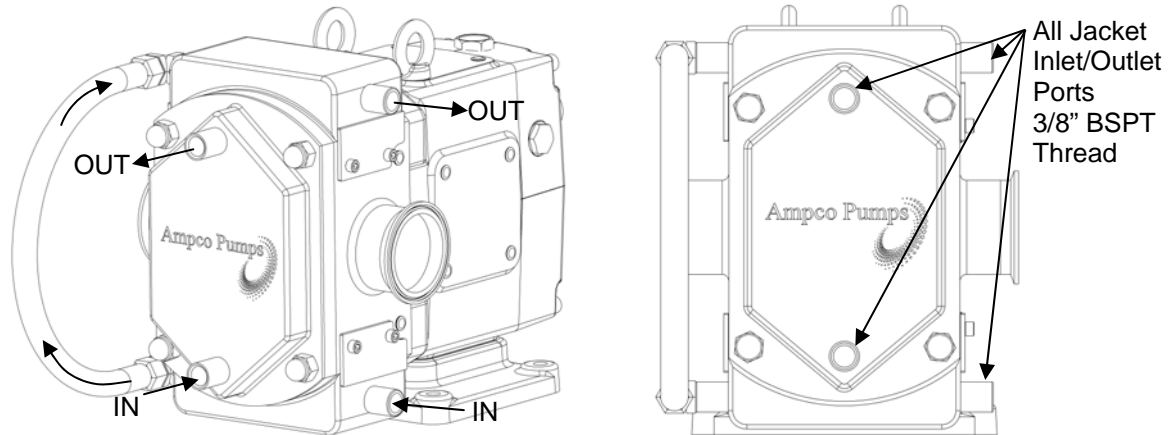

Figure 65: Jacketed Cover

Installation:

Install the casing jackets to the pump casing and fasten them using the jacket bolts. Connect the two jackets with the supplied tube by installing the elbow connections first and then connecting the tube to the elbows (Figure 66, A). The jacketed cover sits over the standard AL cover and uses the same cover nuts to fasten it to the pump. Slide the standard cover and jacketed cover over the studs and secure them using the cover nuts (Figure 66, B).

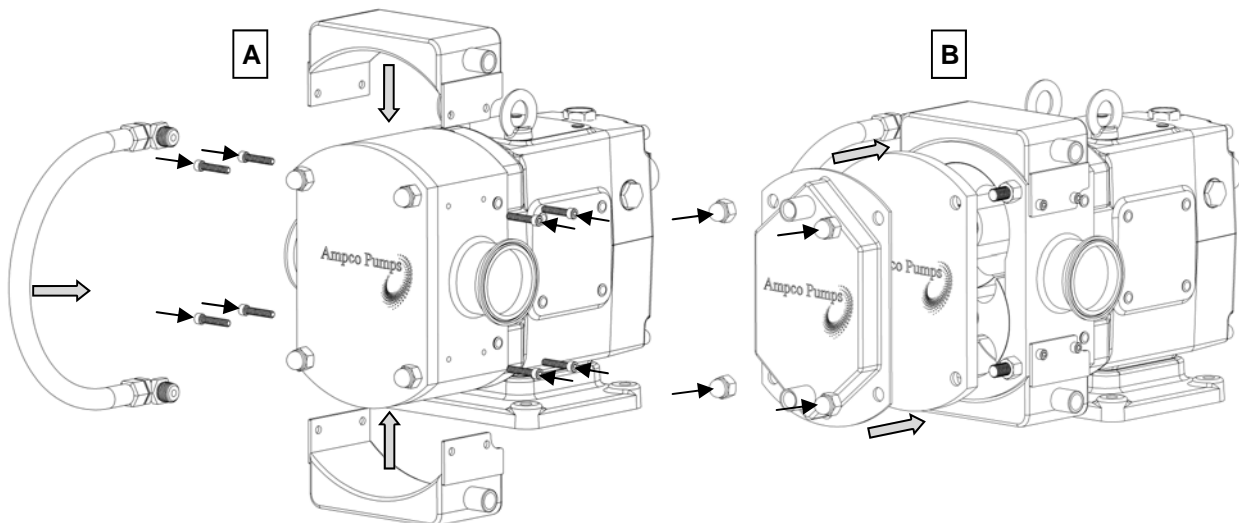

Figure 66: Jacketed Cover Installation

Ampco Pumps Available Options

Vented Cover (Pressure Relief)

The vented cover option is an internal pressure and flow control which works independent of flow (rotational direction). The complete assembly can be seen in Figure 67, A. The relief pressure is set with the adjustment screw and may require in-line pressure gauges for calibration. Non-standard rotor bolts **MUST** be used so no contact is made with the cover (Figure 67, B). Once the cover is assembled install it on the pump and fasten it using the standard cover nuts (Figure 67, C).

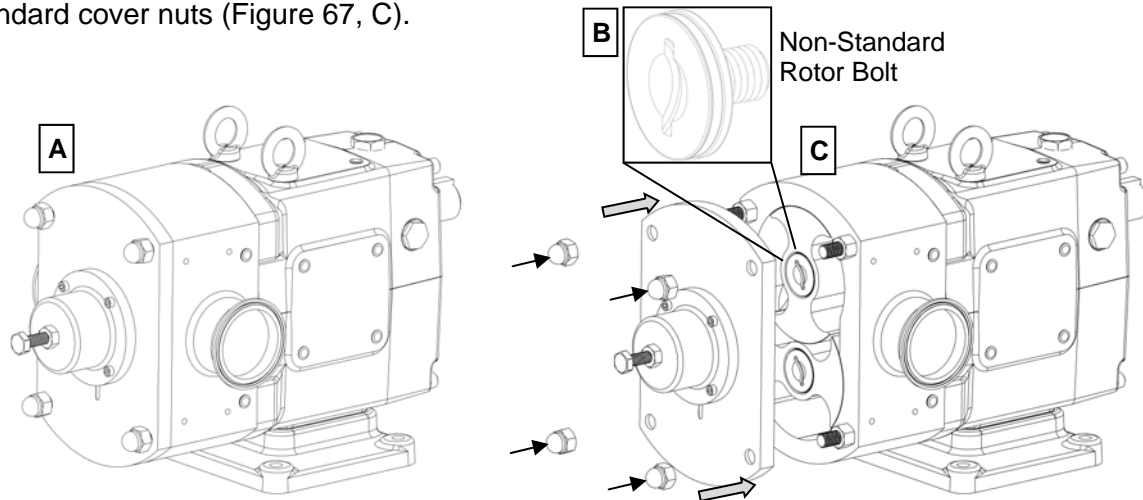
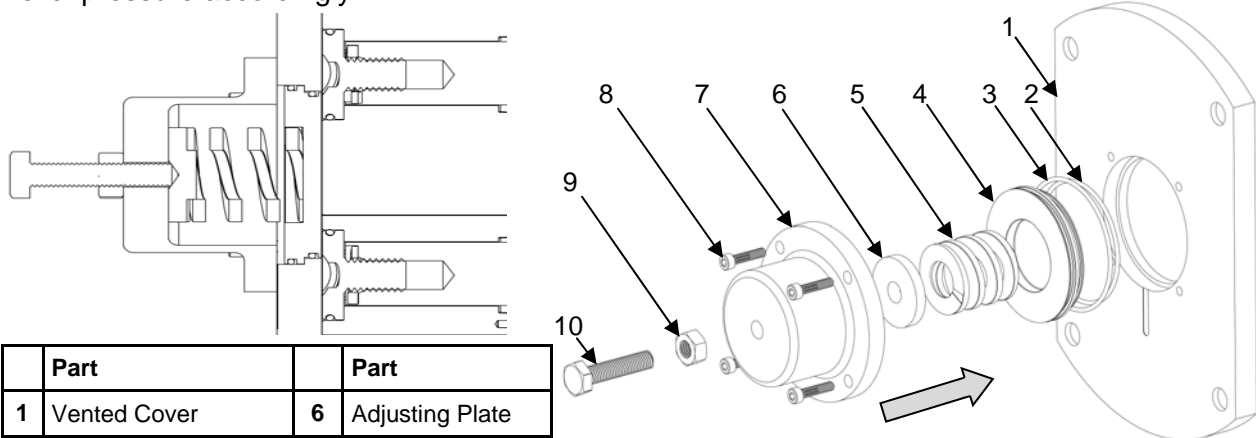

Figure 67: Vented Cover

Installation:

The vented cover assembly can be seen in Figure 68. Assemble on a flat surface and start by inserting the o-rings in the diaphragm. Slide the diaphragm in the cover and set the spring and adjusting plate on it. Set the relief housing on the cover and secure it using the housing bolts. Thread the lock nut onto the adjusting bolt and thread the bolt in the relief housing. Adjust relief pressure accordingly.



Part	Part
1 Vented Cover	6 Adjusting Plate
2 Diaphragm O-ring, #1	7 Relief Housing
3 Diaphragm O-ring, #2	8 Housing Bolts
4 Diaphragm	9 Lock Nut
5 Spring	10 Adjusting Bolt

Figure 68: Vented Cover Assembly

Troubleshooting

Each Ampco AL pump is assembled and tested at the factory and is designed to have trouble-free operation. Problems may occur over the life of the pump due to system variations, standard wear, or user error. The following table has information that may help identify and solve a problem. For additional technical assistance, please contact Ampco with the pump's serial number.

Symptom	Cause	Effect
No Flow (rotors are not turning)	Drive motor is not running or connected	Check connection and power source to pump motor drive
	Keys (gear, drive shaft) are sheared or missing	Check or replace
	The pump's drive (gearbox, belts, transmission) is broken or slipping	Check, replace, or adjust
	Pump shafts or gears are broken	Check and replace, if necessary
No Flow (rotors are turning)	Rotors are turning in the wrong direction	Check motor connections for correct hookup (see "Pump Rotation" on page 11)
	Discharge port/valve is closed or blocked	Check and open, if necessary
	Inlet port/valve is closed or blocked	Check and open, if necessary
	Pump relief valve (optional) is not set correctly, or is held open by foreign matter.	Check and clean, if necessary. Check system so that unwanted debris doesn't enter pump
No Flow (pump is not priming)	Inlet valve closed	Open valve, if necessary
	Inlet line restricted or clogged	Clean lines and check system
	Too much air in the inlet line	Check lines for leaks, replace gaskets or pipes, if needed
	The pump's speed is too low	Increase speed of pump
	The pump's speed is too high	Check viscosity of product, and reduce speed as needed
	No product in the inlet lines (lines drain or siphon when pump is off)	Foot valves or check valves may be used. Having product in the line is necessary for the pump to prime
	Pump is air locked	Install air bleeds to the pump and lines
	Pump may be worn out	Increase the pumps speed or replace worn out rotors.
	Inlet pressures too low	Check pressure required. Change, if necessary
	Differential pressure differences not developing	Install check valves on discharge to prevent large back pressures

Troubleshooting

Symptom	Cause	Effect
Inadequate Flow	Speed is too low or too high	Check published pump curve and adjust speed, if necessary
	Air leaks in inlet line	Check for bad seals, bad gaskets, and piping connections.
Inadequate Flow and Flow is Bypassing Pump	Open valve (inlet drain, trap valve)	Check valves and close, if needed
	Relief valve not adjusted correctly or stuck	Check relief valve and adjust, if necessary
Inadequate Flow, Pump is Noisy During Operation (slipping)	Non-standard rotors (Hot clearance) are being used on low viscous fluids	Use appropriate rotors for product (contact Ampco for additional support, if needed)
	Body and rotors are worn	Increase speeds, replace rotors
	Pressures are too high for pump	Adjust system
Starved Pump Inlet (fluid vaporization)	Strainers, valves (inlet side), fittings, or lines are plugged or restricted	Check and clean lines/valves.
	The Inlet line is too small (inside diameter), too long, or both.	Increase inlet pipe size and/or decrease pipe length
	Too many valves or fittings	Reduce number of fittings or valves
	Valves or strainers are too small	Check and change, if necessary
	The net inlet pressure is too low	Check pump and system requirements and change system or pump, if necessary.
	Product viscosity greater than expected	Change system parameters (temperature, flow, pressure)
	Product temperature is higher than expected	Reduce speed, temperature, and flow, if necessary
Excessive Power is Required (pump overheats, stalls, draws high current, fuses/breakers are tripping)	Viscosity losses higher than expected	Increase pump speed, if needed
	Pressures higher than expected	Decrease pump speeds and modify inlet line sizes
	Viscosity is higher than expected	Heat product, or change system parameters
	Viscous product sits in line during shutdown	Install a soft start on motor drive, clean lines, or change system to avoid problem

Troubleshooting

Symptom	Cause	Effect
Noisy Operation (cavitation)	Product's viscosity, vapor pressure, and temperature are too high	Check system setup. Change speeds and temperatures, accordingly
	The inlet pressure available is less than required	Check inlet pressure requirements and adjust accordingly
Noisy Operation (air or gas in fluid)	Air leaks in the system	Check for leaks and correct, if needed
	Product emits gases	Install pressure relief valves
Noisy Operation (rotor to body contact)	Assembly without checking fluid end clearances	Check pump clearances and adjust, if necessary (page 33)
	Internal stresses in pump caused by improper piping support	Adjust system to eliminate stresses (page 8)
	Pressures are higher than what the pump is rated for	Reduce pressures
	Bearings are worn	Check for bearing movement (page 14) and replace, if necessary
Noisy Operation (rotor to rotor contact)	Gears are loose or incorrectly timed (damage to rotor may be severe)	Rebuild pump with new parts
	Keys are sheared	Inspect and rebuild, if necessary
	Gears are worn	Inspect and replace gears, if needed. Inspect damage to rotors and rebuild, if necessary
Noisy Operation (external mechanical problems)	Gear drive, drive belts, coupling, or bearings are worn or not correctly adjusted	Check and replace. Adjust, if needed
Short Pump Life	Product is abrasive	Check system, and possibly implement a larger pump at lower speeds
	Pump speeds and pressures are higher than pump rating	Check system and change, if necessary. Reduce speeds and pressure of pump
	Improper gear case lubrication	Check and replace worn out gears and bearings; follow procedures on page 12 for proper lubrication
	Water build up in gear case	Check that all gear case plugs are in place
	Misalignment in system (piping or pump drive)	Check and modify system to eliminate alignment issues

ATEX Certification Information

- 1) Ampco Pumps DOC (declaration of conformity) must be included with the pump's installation and maintenance manual.
- 2) ATEX certified pumps will be sent with black plugs on all drain and level ports at the rear of the gear case.
- 3) ATEX approval becomes void if non-Ampco replacement parts are used in the pump.

For additional support regarding ATEX certification, please contact the Engineering Department at Ampco Pumps Company, (414) 643-1852.

AMPCO PUMPS

Made of SELECTED corrosion-resistant alloys

TERMS AND CONDITIONS OF SALE

1. ENTIRE AGREEMENT. This document contains all of the terms and conditions of the agreement (“the agreement”) between Ampco Pumps Company, Inc. (“Seller”) and the purchaser (“Purchaser”) of the Products (“Products”) to be sold to Purchaser, to the exclusion of any other statements and agreements, and to the exclusion of any terms and conditions incorporated in Purchaser’s order or other documents of Purchaser. Seller’s acceptance of Purchaser’s order is expressly conditioned on Purchaser’s acceptance of the terms and conditions contained herein, and Purchaser, upon placing an order, is presumed to have accepted all the terms and conditions without modification. No alteration, waiver, modification of or addition to the terms and conditions herein shall be binding on Seller unless set forth in writing and specifically agreed to by an officer of Seller. No course of dealing, usage of trade or course of performance will be relevant to supplement or explain any terms used in the agreement. All offers to purchase, quotations and contracts of sale are subject to final acceptance by Seller at its home office at Milwaukee, Wisconsin.

2. PRICES. Prices for Products manufactured by Seller pursuant to written accepted orders will remain firm for thirty (30) days from the date of any subsequent price change.

3. TERMS OF PAYMENT. Standard terms are ½% 10 days, 30 days net, from date of invoice unless otherwise stated. If, in the judgment of Seller, the financial condition of Purchaser at any time does not justify continuance of production or shipment on the terms of payment specified, Seller may require full or partial payment in advance. In cases of delays in payment, Seller reserves the right to charge interest on delinquent balances at the rate of 1 ½% per month.

4. DELIVERY. Except as otherwise provided expressly stated in the agreement, Products are sold F.O.B. Milwaukee. Seller will use reasonable commercial efforts to fill orders within the time stated, but the stated delivery date is approximate only, and Seller reserves the right to readjust shipment schedules without liability. Acceptance by Purchaser of the Products waives any claim for loss or damage resulting from a delay, regardless of the cause of the delay. Except as otherwise provided herein, Seller will not be responsible for freight, transportation, insurance, shipping, storage, handling, demurrage or similar charges. Claims by Purchaser for shortages in the Products must be made to Seller in writing within ten (10) days after date of receipt of the Products. No such shortage shall entitle Purchaser to withhold payment for Products which were received by Purchaser. Each such claim shall set forth in detail the basis and amount of such claim.

5. TAXES AND FEES. Seller shall pay all present and future sales, excise, privilege, use or other taxes, customs duties, and all other fees or other costs, imposed by any federal, state, foreign, or local authorities arising from the sale, purchase, transportation, delivery, storage, use or consumption of the Products or will, if applicable, provide Seller with an appropriate exemption certificate. Seller shall be under no obligation to contest the validity of any such taxes or to prosecute any claims for refunds or returns.

6. INSTALLATION. The Products shall be installed by and at the expense of Purchaser.

7. LOSS, DAMAGE OR DELAY. Seller will not be liable for loss, damage or delay resulting from causes beyond its reasonable control, including, without limitation, strikes or labor difficulties, lockouts, acts or omissions of any governmental authority or Seller, insurrection or riot, war, fires, floods, Acts of God, breakdown of essential machinery, accidents, embargoes, cargo or material shortages, delays in transportation, lack of production capacity or inability to obtain labor, materials or parts from usual sources. In the event of any such delay, performance will be postponed by such length of time as may be reasonably necessary to compensate for the delay. In the event performance by Seller under the agreement cannot be accomplished by Seller due to any of the foregoing causes within a reasonable period of time, Seller may, at its option, terminate the agreement without liability.

8. RETURNS. No Products or parts may be returned by Purchaser without the prior written consent of Seller.

9. WARRANTY. Seller warrants that the Products manufactured by Seller will be free from defects, material and workmanship under normal use and service for a period of one (1) year from date of shipment. In addition, the specified rating of each pump is warranted; however, the characteristic shape of the performance curves may vary from the published standards, and the capacity, head and efficiency guarantees are based on actual shop tests using clear cold water, and therefore the rating is specified in equivalent units of clear cold water. The sole obligation of Seller and the exclusive remedy of Purchaser for breach of this warranty shall be the repair (at Seller’s facility) or replacement by Seller (F.O.B. Milwaukee, Wisconsin), at Seller’s option, of any parts found to be defective, without charge and shall be conditioned upon Seller receiving written notice of any alleged breach of this warranty within a reasonable time after discovery of the defects, but in no event later than the end of the warranty period. The parts alleged to be defective shall be returned to Seller upon its request, freight prepaid. This warranty does not cover ordinary wear and tear, abuse, misuse, overloading, alteration or Products or parts which have not been installed, operated or maintained in accordance with Seller’s written instructions. Seller shall not be liable for any expenses for repairs, additions or modifications to the Products outside of Seller’s factory without its prior written consent, and any such repairs without such consent shall void this warranty. THIS WARRANTY IS EXCLUSIVE AND IS IN LIEU OF ALL OTHER EXPRESS AND IMPLIED WARRANTIES WHATSOEVER, INCLUDING BUT NOT LIMITED TO IMPLIED WARRANTIES OF MERCHANTABILITY AND FITNESS FOR A PARTICULAR PURPOSE. Seller may from time to time provide its facilities, personnel and experience to assist customers in the selection of materials, design, installation and operation of Products for maximum resistance to corrosion and abrasion with due consideration to the economy of the installation. This service is provided in an advisory capacity only and the final selection and operation of the Products and ancillary equipment shall be the sole responsibility of Purchaser or any user thereof. Accessories and parts manufactured by third parties are warranted only to the extent of such third party’s warranty. IN NO EVENT SHALL SELLER BE LIABLE UNDER ANY CIRCUMSTANCES FOR ANY INCIDENTAL, CONSEQUENTIAL OR SPECIAL DAMAGES (INCLUDING, WITHOUT LIMITATION, ANY LOST PROFITS OR LABOR COSTS) ARISING FROM THE BREACH OF THIS WARRANTY OR OTHERWISE ARISING FROM OR RELATING TO THE PRODUCTS OR THEIR SALE, USE OR INSTALLATION.

Terms and Conditions

Ampco Pumps Company

10. CHANGES. Changes in any work to be performed hereunder may be made only upon Purchaser's written instructions and acceptance by Seller in its discretion. Any change in drawings, materials or design of the Products, or to tools, fixtures or other items used to produce the Products, which affects Seller's cost to produce the Products will entitle Seller to adjust the price to take into account any additional costs. If work has been started, Seller shall be properly reimbursed for work already performed; if Products already produced are not accepted by Purchaser, Seller has the right to adjust the price to take into account any additional costs caused by an increase or decrease in quantities or in the time required for performance under the agreement.

11. TERMINATION. After Seller has commenced work, ordered any materials or made any other commitments pursuant to the agreement, it may be terminated only with the prior written agreement of Seller providing for equitable cancellation charges. Such charges shall reimburse Seller for any completed items at the contract price, and for any work-in-process items at the contract price less the cost to complete. Termination on any other basis must be specifically agreed on in writing in advance between Purchaser and Seller.

12. DEFERRED DELIVERIES. Orders or deliveries will be deferred only upon the prior written agreement of Seller in its discretion, and then only upon the following conditions:

(a) The deferral period may not exceed sixty (60) days. At the end of the deferral period, if no release is provided by Purchaser, Seller reserves the right to render an invoice for and ship the completed portion of the order to the destination specified in Purchaser's order, or to store such material at Purchaser's expense at Seller's standard storage charges then in effect.

(b) For the portion of the order that is not completed, if no release is provided by Purchaser at the expiration of the deferral period, Seller reserves the right to render an invoice for any completed items at the contract price, and for any work-in-process items at the contract price less the cost to complete.

(c) Purchaser shall bear the risk of loss or damage to materials held at Purchaser's request.

13. LIMITATION OF LIABILITY. IN NO EVENT SHALL SELLER BE LIABLE UNDER ANY CIRCUMSTANCES: (a) FOR ANY INCIDENTAL, CONSEQUENTIAL OR SPECIAL DAMAGES (INCLUDING, WITHOUT LIMITATION, ANY LOST PROFITS OR LABOR COSTS) ARISING FROM OR RELATING TO THE PRODUCTS OR THEIR SALE, USE OR INSTALLATION; (b) FOR DAMAGES TO PROPERTY (OTHER THAN THE PRODUCTS PURCHASED FROM SELLER); (c) FROM ANY BREACH OF ITS WARRANTY OR ANY OTHER OBLIGATIONS TO BUYER; OR (d) FOR ANY OTHER CAUSE WHATSOEVER, WHETHER BASED ON WARRANTY (EXPRESSED OR IMPLIED) OR OTHERWISE BASED ON CONTRACT, OR ON TORT OR OTHER THEORY OF LIABILITY, AND REGARDLESS OF ANY ADVICE OR REPRESENTATIONS (WHETHER OR NOT IN WRITING) THAT MAY HAVE BEEN RENDERED BY SELLER CONCERNING THE DESIGN, MANUFACTURE, SALE, USE OR INSTALLATION OF THE PRODUCTS.

14. INFRINGEMENT. Seller at its expense will defend and hold Purchaser harmless from and against all damages, costs and expenses arising from any valid claim of infringement by a third party with respect to any patent or other intellectual property rights (collectively, the "Intellectual Property Rights") caused by Products originally manufactured by Seller, provided Purchaser (a) has not modified such Products, (b) gives Seller immediate notice in writing of any claim or commencement or threat of suit, and (c) permits Seller to defend or settle the same, and gives all immediate information, assistance and authority to enable Seller to do so. In the event any such originally manufactured Products are held to infringe an Intellectual Property Right and if Purchaser's use thereof is enjoined, Seller will, at its expense and option: (1) obtain for Purchaser the right to continue using the Products, (2) supply non-infringing Products, (3) modify the Products so that they become non-infringing, or (4) refund the then market value of such Products. In no event shall Seller's liability exceed the sale price of the infringing Products. THE FOREGOING REPRESENTS SELLER'S ENTIRE AND EXCLUSIVE OBLIGATION WITH RESPECT TO ANY CHARGE OF INFRINGEMENT OF ANY INTELLECTUAL PROPERTY RIGHT AND IS IN LIEU OF ANY STATUTORY WARRANTY RELATING TO INFRINGEMENT. Notwithstanding the foregoing, Seller shall have no liability as to any Products or parts thereof that are manufactured or modified by Purchaser or a third party, or that are manufactured or modified by Seller in accordance with Purchaser's specifications. Purchaser will defend and hold Seller harmless from and against all damages, costs and expenses whatsoever arising from any claim for infringement of any Intellectual Property Rights relating to Products that have been manufactured or modified by Seller according to specifications provided by Purchaser.

15. CERTAIN LAWS. Seller will comply with the applicable requirements of the Fair Labor Standards Act of 1938, as amended, Executive Order 11246, and THE rules, regulations and orders of the Secretary of Labor relating thereto.

16. PERIOD FOR ACCEPTING QUOTATIONS. Unless accepted without modification within thirty (30) days of issuance, or prior to withdrawal by Seller if earlier, all quotations automatically expire at the end of such thirty (30) day period.

17. PROVISIONS FOR INTERNATIONAL TRANSACTIONS. The following provisions shall apply if the Products are to be shipped to Purchaser at a location outside the United States, and apply regardless of other provisions set forth in these Terms and Conditions:

(a) The 1980 United Nations Convention on Contracts for the International Sale of Products shall not apply.

(b) Except as otherwise provided expressly stated in the agreement, terms of delivery are Ex-Works (within the meaning of INCOTERMS 2000) and all customs fees, import duties, cargo insurance, taxes and other charges imposed on or relating to the purchase or sale of the Products shall be paid by Purchaser in addition to the stated price.

(c) Except as otherwise provided expressly stated elsewhere in the agreement, payment shall be made by issuance to Seller of an irrevocable letter of credit which (i) is issued and confirmed by a U.S. bank acceptable to Seller, (ii) is governed by the Uniform Customs and Practice for Documentary Credits (UCP 600) and otherwise acceptable in form and substance to Seller, and (iii) provides for payment to Seller of the purchase price in U.S. dollars upon presentation by Seller of Seller's certification and/or such other documents as shall be required by the letter of credit. All banking and other charges for such letter of credit shall be for the account of Purchaser.

(d) Prices include Seller's standard commercial export packaging which may vary depending on whether shipment is made by air, land or sea. Except as otherwise provided expressly stated in the agreement, Purchaser will bear any additional expenses required to satisfy Purchaser's packaging requirements. Packages will be marked in accordance with Purchaser's instructions, if any. Seller shall furnish packing lists and such other information as may be necessary to enable Purchaser's agent to prepare documents required for export shipment.

(e) All shipments hereunder are subject to compliance with the U.S. Export Administration Act, as amended, regulations thereunder and all other U.S. laws and regulations concerning exports. Purchaser shall comply with all such laws and regulations concerning the use, disposition, re-export and sale of the Products provided hereunder.

18. GENERAL. No modification or waiver of the agreement or any of its provisions is valid unless expressly agreed to by Seller in writing, and no waiver by Seller of any default under the agreement is a waiver of any other or subsequent default. The unenforceability or invalidity of one or more of the provisions of the agreement will not affect the enforceability or validity of any other provision of the agreement. Purchaser may not assign any of its rights, duties or obligations under the agreement without Seller's prior written consent and any attempted assignment without such consent, even if by operation of law, will be void. The agreement is governed by and shall be construed in accordance with the laws of the State of Wisconsin, including the Uniform Commercial Code as enacted by such state, without giving effect to its conflict of laws principles.

Return Policy

Ampco Pumps Company

This policy is intended for returns that are not covered by product warranty, i.e. wrong pump or part was ordered, customer canceled order, etc. Before returning any product, contact us for a Returned Material Authorization Number (RMA#). This will eliminate confusion when the parts are received and facilitate processing the return. No action will be taken on returned parts without an RMA.

<u>Type of Return</u>	<u>Restocking Charge</u>
Standard pump with a replacement order	10%
Standard pump without a replacement order	20%
Standard parts with a replacement order	5%
Standard parts without a replacement order	10%

Additional restocking charges may be assessed for any of the following circumstances.

1. Special order motors and seals are not returnable unless we have a use for them. Credit will be determined on a case-by-case basis.
2. Impellers that are trimmed to a diameter that we don't regularly use are not returnable. Credit will be determined on a case-by-case basis.
3. Used seals and motors are not returnable.
4. For any pumps and/or parts purchased over (1) year ago, credit will be determined on a case-by-case basis.

Credits

Credit will be issued only after parts are returned and inspected. Customer is responsible for packaging parts so they are returned in "as new" condition. Any labor required by Ampco to return the parts to "as new" condition will be deducted from the credit.



Ampco Pumps Company
2045 W. Mill Road
Glendale, WI 53209
Phone: (800) 737-8671 or (414) 643-1852
Fax: (414) 643-4452
Email: ampcocs@ampcopumps.com

For additional information on the AL series and other Ampco Pumps products, please visit our website: www.ampcopumps.com