

# Ampco Centrifugal Pumps

## DATA SHEET

MODEL AC/AC+ 1 1/2 X 1 1/2

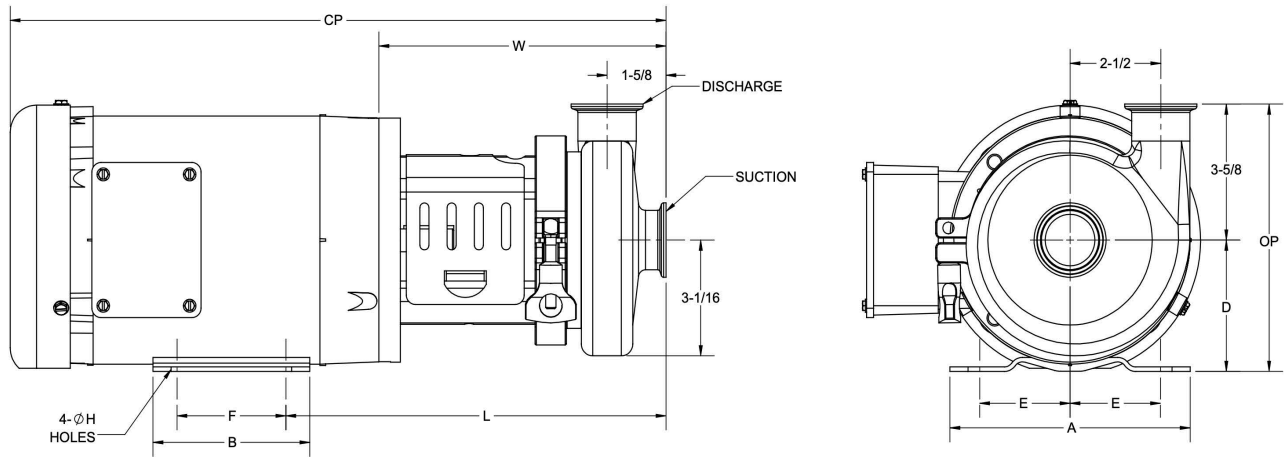
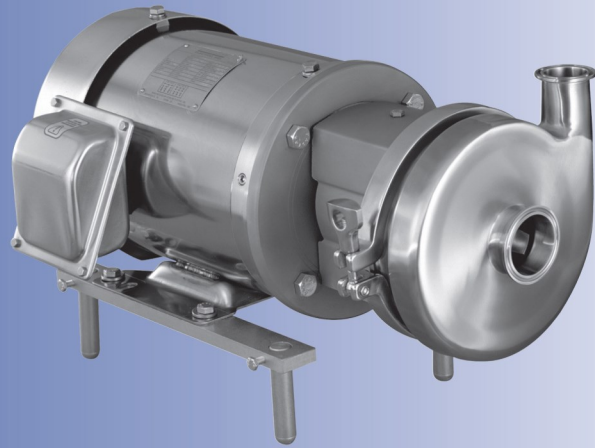

TEFC MOTOR			DIMENSIONS IN INCHES (For Reference Only)										APPROX WEIGHT (LBS)
HP	RPM	FRAME	A (typ)	B (typ)	D	E	F	ØH	L	W	CP	OP	
1/4	1750	56C	6-9/16	4-1/4	3-1/2	2-7/16	3	11/32	10-1/2	7-15/16	16-15/16	7-1/8	20
1/2	1750	56C	6-9/16	4-1/4	3-1/2	2-7/16	3	11/32	10-1/2	7-15/16	16-15/16	7-1/8	20
1/2	1750	56C	6-9/16	4-1/4	3-1/2	2-7/16	3	11/32	10-1/2	7-15/16	16-15/16	7-1/8	41
3/4	3500	56C	6-9/16	4-1/4	3-1/2	2-7/16	3	11/32	10-1/2	7-15/16	16-15/16	7-1/8	42
1	3500	56C	6-9/16	4-1/4	3-1/2	2-7/16	3	11/32	10-1/2	7-15/16	16-15/16	7-1/8	44
1-1/2	3500	56C	6-9/16	4-1/4	3-1/2	2-7/16	3	11/32	10-1/2	7-15/16	17-15/16	7-1/8	59
1-1/2	3500	143TC	6-1/2	6	3-1/2	2-3/4	5	11/32	10-3/4	7-15/16	18-15/16	7-1/8	59
2	3500	56C	6-9/16	4-1/4	3-1/2	2-7/16	3	11/32	10-1/2	7-15/16	17-15/16	7-1/8	73
2	3500	145TC	6-1/2	6	3-1/2	2-3/4	5	11/32	10-3/4	7-15/16	18-15/16	7-1/8	66
3	3500	145TC	6-1/2	6	3-1/2	2-3/4	5	11/32	10-3/4	7-15/16	18-15/16	7-1/8	75
5	3500	184TC	8-5/8	6-1/2	4-1/12	3-3/4	5-1/2	13/32	11-5/8	8-1/4	23-7/16	8-1/16	98

## MATERIAL SPECIFICATIONS

PART NAME	STAINLESS STEEL
Casing	316L Stainless
Backplate, Impeller, Stub Shaft	316L Stainless
Adapter	304 Stainless

# Ampco Centrifugal Pumps

MODEL AC/AC+ 114 1 1/2 X 1 1/2

Curves show approximate characteristics  
based on clear 68° water.  
Rated point is guaranteed.

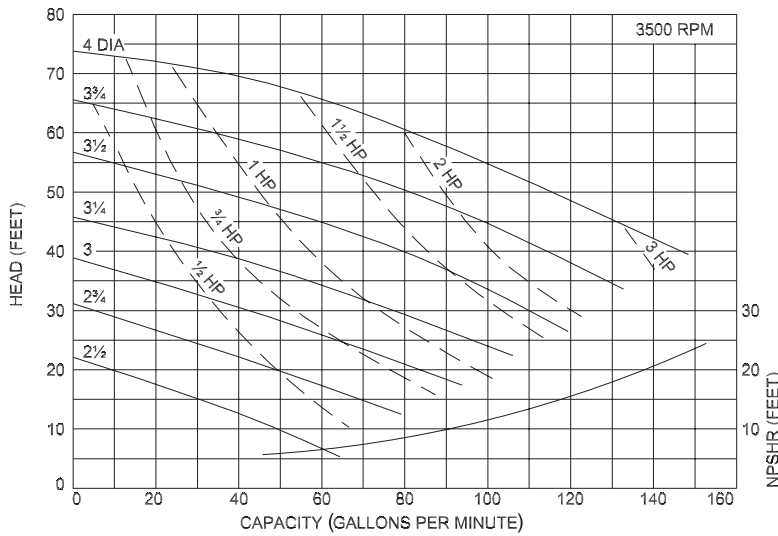

AC/AC+ Series pumps have standard stainless steel adapters and Type D, DG, & E seals available.

AC/AC+ Series pumps are in conformance with 3A sanitary standards for centrifugal and positive rotary pumps for milk and milk products,  
Number 02-10.

AC/AC+ Series pumps have a standard 32RA (150 grit) finish, on all product contact surfaces.

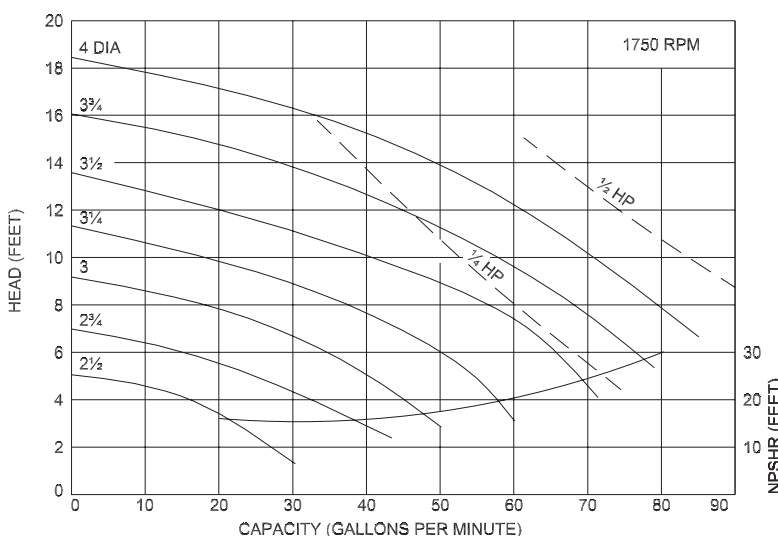
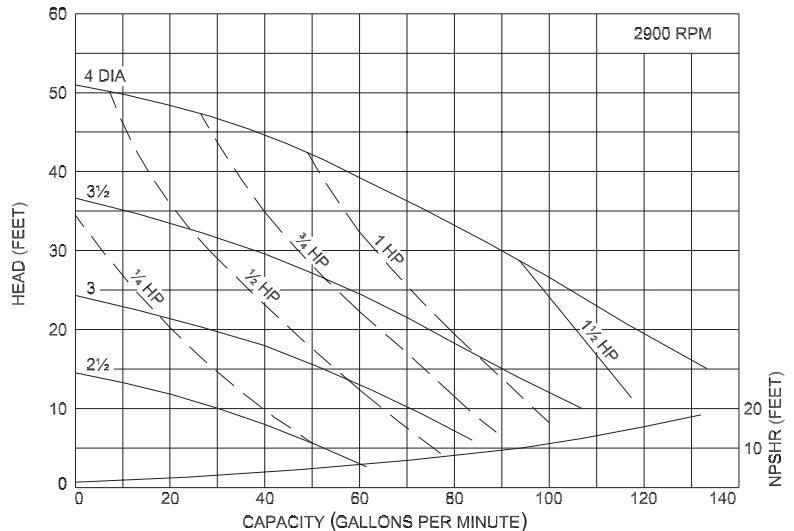

# Ampco Pumps Company

2045 West Mill Road  
Glendale, Wisconsin 53209  
PHONE (414) 643-1852  
FAX (414) 643-4452