

Ampco Pumps Company



AC / AC+ Centrifugal Pumps



Maintenance, Service, and Installation Manual

TABLE OF CONTENTS

SAFETY	3
INTRODUCTION	4
INSTALLATION	4
PIPING AND CONNECTIONS	5
SUCTION PIPING	5
DISCHARGE PIPING	5
LOCATING VALVES	5
OVERVIEW	6
EXPLODED VIEW	7
PARTS LIST	8
AC+ EXPLODED VIEW	9
ASSEMBLY	10
LEG BRACKET ASSEMBLY	10
ADAPTER ASSEMBLY	10
IMPELLER AND STUB SHAFT	10
STANDARD STUB SHAFT	11
THREADED STUB SHAFT	11
AC+ SHAFT	11
MECHANICAL SEALS	12
“D” AND “F” SEAL	12
“DG” SEAL	13
“E” SEAL	14
CONVERSION KIT	17
INDUSTRIAL T21 SEAL ASSEMBLY	18
INSPECTION	19
IMPELLER RETENTION	19
CASING ASSEMBLY	20
PUMP CHECK	20
TROUBLESHOOTING	21
TERMS AND CONDITIONS	22
RETURN POLICY	24

Safety

DO NOT attempt to modify any Ampco Pumps product, the AC Series centrifugal pump has been designed to be safe and reliable, to do so could create unsafe conditions and void all warranties.

DO NOT place any Ampco Pumps product in an application where general product service ratings are exceeded. Personal injury or machinedamage may occur if maintenance and operation personnel do not observe the instructions in this manual.

The following **DANGER**, **WARNING**, and **CAUTION** signs and their meanings are used within this manual to avoid serious injury and/or possible damage to equipment.

 DANGER
Indicates an imminently hazardous situation, and if not avoided, will result in death or serious injury. The word danger is used in the most extreme cases.

CODE 136530001
(Rotating direction CCW)



 WARNING
Indicates a potentially hazardous situation and, if not avoided, could result in minor or moderate injury. This will also be used to alert against an unsafe operating or maintenance practice.

CODE 136530002
(Guard warning)



 CAUTION
Indicates a potentially hazardous situation and, if not avoided, could result in death or serious injury.

Safety labels are placed on every pump. **DO NOT** remove any labeling on any Ampco Pumps product. Replace any label that is missing.

Introduction

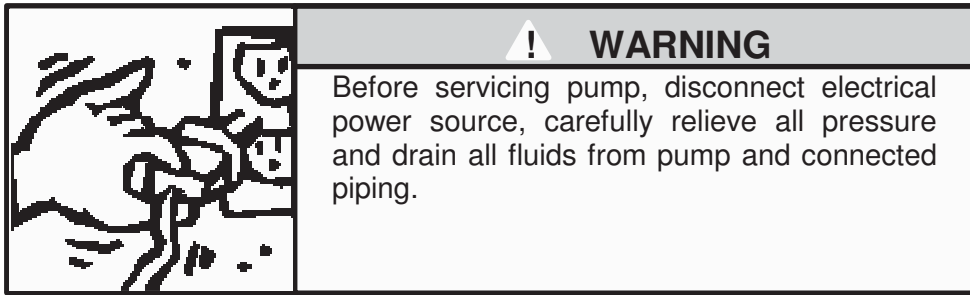

The AC Series closed-coupled pumps are made up of two sections, the power or drive section and the liquid end or pump section.

The pump is mounted to the frame of the drive motor by means of an adapter, and is coupled to the motor shaft. The impeller mounts on the stub shaft and is retained by one of the three methods. The casing is clamped to the adapter, greatly simplifying removal and also permitting positioning of the discharge outlet through 360°. The external balance seal assures long seal life. The drive motor is mounted on a frame having adjustable legs providing simple installation and leveling.

Installation

Unpacking the Equipment

Check the contents and all wrapping when unpacking your equipment. Inspect all parts for damage that may have occurred during shipping. Report any damage to the carrier.

Location and Installation

The pump unit should be located as close as possible to the liquid source and in a position where the suction piping can be short and direct with minimal fittings. It should also be readily accessible for inspection and cleaning.

The pump unit is shipped ready for installation from the factory. To install it, attach a hoist if necessary, loosen the set screws in the adjusting leg brackets, and individually adjust the legs until the pump is leveled. Tighten the set screws.

Attach the suction and discharge piping. Be sure suction and discharge piping is properly supported to avoid any strain on the pump casing.

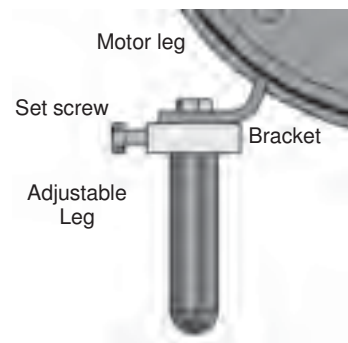

Piping and Connections

General

This section provides some do's and do not's of piping which will aid in obtaining the maximum efficiency and service from your pump. Piping should be independently supported at both the suction inlet and discharge outlet. Care should be taken that piping is properly aligned and does not put any strain on the pump casing. The piping should have as few bends as possible.

Suction Piping

The suction piping should be short and follow a direct route with a minimum number of elbows and fittings. Elbows should be located as far as possible from the suction inlet to prevent head loss due to increased friction. Excessive friction losses in the suction line could result in pump cavitation, poor performance, noise, vibration, damage to equipment, and possible damage to fluid.

Whenever possible, the diameter of the piping at the suction inlet should be increased in size, an eccentric tapered reducer should be used instead of a concentric tapered reducer to prevent air pockets from forming and impairing pump efficiency. In turn, the eccentric reducer may be placed at the inlet of the pump and should be positioned so the straight side is up.

A horizontal suction pipe must have a gradual rise to the pump. A high point in the suction line will form an air pocket and prevent proper pump operation. All joints in the suction line should be air tight, to prevent air leakage which can reduce pump capacity and efficiency.

Discharge Piping

Position of the pump discharge is preferably either vertical or top horizontal. The discharge piping should be short and direct with a minimal number of elbows and fittings. Elbows should not be used at the discharge outlet, as the friction encountered would be increased, resulting in head loss. However, use of a larger discharge pipe than recommended may reduce the total pump head, but increase the pump volume, which can cause pump vibration due to overload. Use of a discharge pipe smaller than the pump discharge outlet increases the total pump head but decreases the volume. If a reducer is required on the outlet port of the pump and the discharge is vertical a concentric reducer should be used. If the discharge is horizontal an eccentric reducer should be used and should be positioned so the straight side is down.

Locating Valves

In suction lift applications where the lift is not very high, it may be desirable to install a foot valve, to facilitate priming and to prevent draining off of the liquid back to the source. A throttling valve should be installed in the discharge piping to control pump flow rate and prevent motor overload.

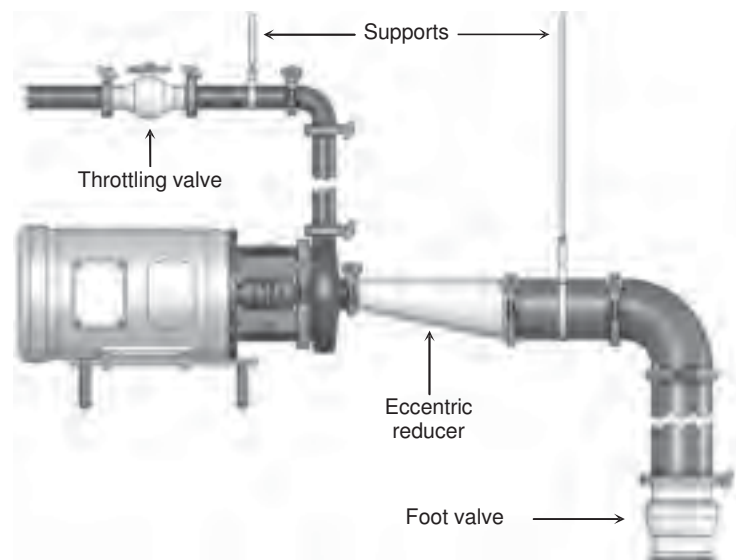

Overview

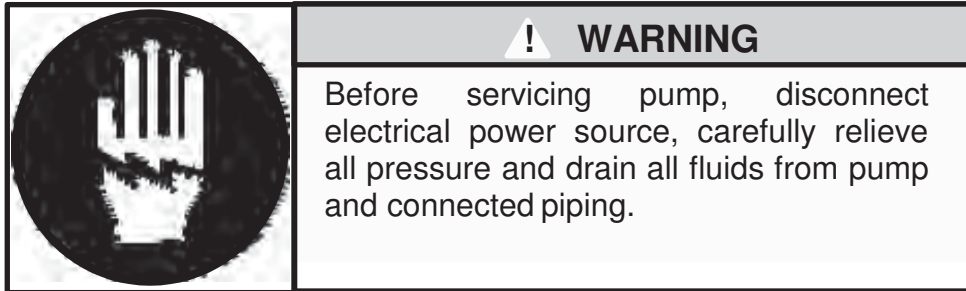

Before beginning the assembly procedure identify every element that is going to be installed, you can use the exploded view and part list shown on pages 7 and 8. During the assembly you may need the following tools:

- a. 1", 3/4", 9/16" and 1/2" wrenches
- b. 1/8", 5/32", 3/16" and 1/4" Allen wrenches
- c. Rubber mallet
- d. Vernier caliper, useful with assemble seal type "E"
- e. 5/8" & 7/8" socket – for impeller nut, for AC+ models
- f. 3/8" diameter steel rod – to hold stub shaft plus, for AC+ models

Recently Ampco Pumps added to the AC Series line: AC+ conversion kit, AC+ Series and IC+ Series for specific applications. There are some modifications required to the assembly for each one of these without altering the operation of the equipment.

AC+ Conversion Kit

The kit is made up of a stub shaft, a stub shaft collar, a shaft key, an impeller, an impeller nut, and front and back impeller gaskets. The collar may use one or two screws according to the pump model. This assembly works exactly the same as a standard assembly from the AC series.

AC+ Series

The AC+ Series was developed to facilitate the assembly of the AC Series pumps while offering some advantages. The AC+ Series provides more stable performance when mounting the stub shaft onto the motor using a collar. The stub shaft is threaded and offers a more secure mount for the impeller by means of a key and a nut. This advantage is critical to pump longevity while maintaining 3A Sanitary Certification. An ordinary AC Series pump can be turned into an AC+ series with a conversion kit.

IC+ Series

The IC+ is the same as the AC+ but designed for industrial purposes. It uses an internal mechanical seal denominated T21 which lodges in an industrial back plate. Because of this, the IC+ does not meet the 3A regulations. No other mechanical seal from the AC Series is compatible with the IC+ Series. An ordinary AC Series pump can be turned into an IC+ Series with a conversion kit, an industrial back plate, and a mechanical seal type T21.

Parts List

External balanced seal type D		
11	Backplate "D"	1
11F	Backplate pin	2*
80	Carbon	1
80A	Cup seal "D"	1
80B	O-ring carbon	1
80C	Spring seal "D"	1
80K	Set screw collar seal "D"	2
80L	Drive collar "D"	1
Clamped-in seat seal type DG		
11F	Backplate pin	2*
11H	Backplate "DG"	1
17J	Gland ring "DG"	1
17K	Bolt/screws gland ring	4**
17M	Lock washer	4**
80N	Seal seat "DG"	1
80P	PTFE gasket	1***
80R	PTFE gasket	1***
Leg brackets		
207	Adjustable leg	4
209	Adjustable leg bracket	2
209A	Set screw	4
209B	Bracket mounting screw	4
Kit plus		
2P	Impeller plus	1
6P	Stub shaft plus	1
24C	Shaft key plus	1
24D	Nut plus	1
91A	Back gasket plus	1
91B	Front gasket plus	1
92	Drive collar plus	1
92A	Bolt drive collar	1**
Threaded stub shaft		
6A	Set screw (shaft)	**
6F	Threaded stub shaft	1
24A	Castellated nut (impeller)	1
24B	Cotter pin (impeller)	1

Water cooled balanced double seal type E		
11B	Backplate "E"	1
11F	Backplate pin	2*
17	Follower	1
17A	Machine screw	4**
17B	O-ring	1
17C	Lock washer	4**
80	Carbon	2
80B	O-ring	2
80G	Cup seal "E"	2
80H	Spring seal "E"	1
80J	Drive collar "E"	1
80M	Set screw drive collar "E"	2
83C	Stuffing box "E"	1
83D	Machine screw	4**
83E	O-ring	1
AC+ Conversion Kit		
	Conversion kit	1
11F	Backplate pin	2*
11P	Industrial backplate	1
95	Seal T21	1
Common components		
1	Casing	1
2	Impeller	1
6A	Set screw (shaft)	**
6E	Stub shaft	1
24	Retainer (impeller)	1
40	Deflector	1
71	Adapter	1
71A	Adapter pin	2*
71B	Adapter mounting screw	4
75	Clamp assembly complete	1
90	Casing gasket	1
131	Seal guard assembly	1
131A	Set screw	1
132	Water cascade assembly	1
M	Motor	1

* Not necessary in some models

** Quantity may vary with model

*** Not interchangeable

AC Series Maintenance Manual Addendum for AC+ Design Pumps

Additional Parts for AC+ Design

Key	Description	Qty
2P	AC+ Impeller	1
6E	AC+ Stub shaft	1
25	AC+ Impeller nut	1
25A	AC+ Impeller nut gasket	1
25B	AC+ Impeller back gasket	1
26	AC+ Shaft Collar	1
27	AC+ Impeller Key	1

AC+ Shaft Design Drawing

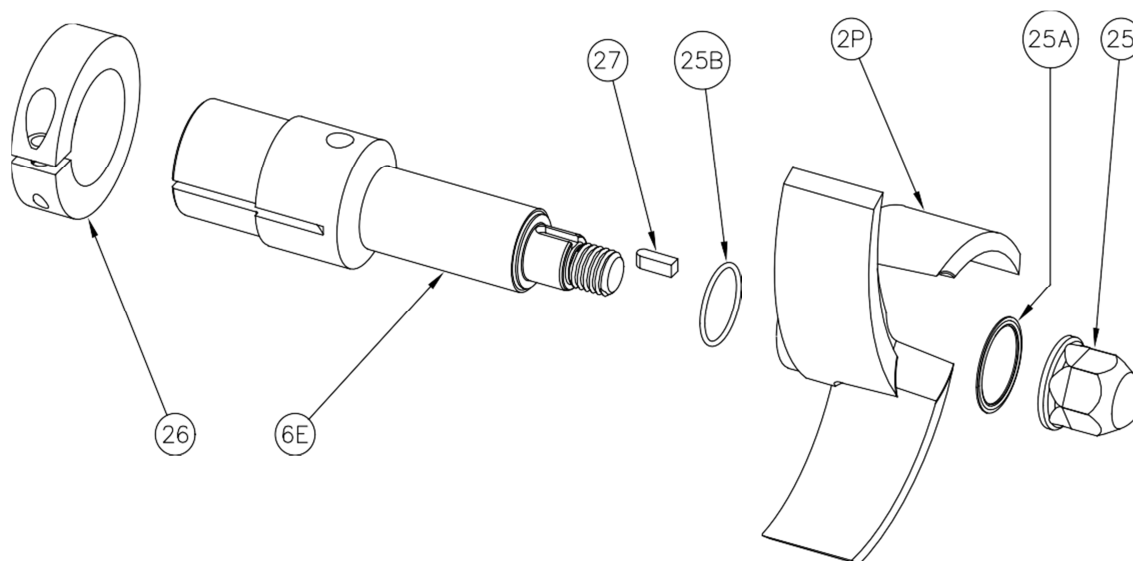

Necessary Equipment

- 3/8" Diameter Rod – For securing shaft when tightening/loosening impeller nut
- 5/8" Socket Wrench – For impeller nut AC+ 114 Pumps
- 7/8" Socket Wrench – For impeller nut AC+ 216, 218, 328, & 4410 Pumps

Bolt Torques

Collars

56C/140TC/180TC	15 ft-lbs
210TC/250TC	30 ft-lbs
280TC/280TSC/320TC/320TSC	40 ft-lbs

Impeller Nuts

AC+ 114	18 ft-lbs
AC+ 216/218/328/4410	40 ft-lbs

Assembly

By getting to know the configurations of our centrifugal pumps from the AC, AC+, and IC+ Series you can learn to assemble our pumps. Some of the instructions that describe the assembly process correspond to various common components of each of the three series of centrifugal pumps. However, when it is time to actually carry out the assembly of a part unique to a particular series, the assembly manual will adequately point that out (i.e. mechanical seals, conversion kit). It is highly recommended that you resort to the diagram on page 7 to verify the assemblies and sub-assemblies.

Leg Bracket Assembly

Sets of leg-brackets are optional and can be used to vertically adjust the pump. The size of the brackets (209) and the legs (207) depend upon the NEMA or IEC of the motor. First, complete the primary assembly of the legs and the brackets, using the hexagonal screws (209A) to tighten the legs to the brackets. Next, use the hexagonal screws (209B) to tighten the brackets to the motor (210). You may need to lift the motor to complete this part of the assembly.

Adapter Assembly

Place the stainless steel adapter on the motor and tighten using four hexagonal screws (71B). The adapter should be accompanied by two adapter pins, which normally come preinstalled. If not, insert them in the corresponding drilled holes. These pins serve to set the backplate (11) to the adapter (71), hooking the backplate onto the adapter pins using the two backplate pins (11F) located on the backplate. Depending upon the pump model and seal type, some backplates do not have pins for reasons of design.

Important: The adapter comes with a protective guard (131) which comes attached by a hexagonal screw (131A). It is highly recommended for safety reasons not to operate the pump if this guard is not placed on the adapter.

Impeller and Stub Shaft

To set the stub shaft onto the motor, it is necessary to place it at the proper distance. To find this position, it is necessary to provide a spacing of seventy one-thousandths of an inch (0.070 in.) between the impeller and the backplate, as shown below in figure A. You can make this adjustment using a Vernier caliper or spacing gauge.



Figure A
Spacing of the Impeller and Stub Shaft

Depending on the pump model and the seal type, the backplate requires two pins (11F), which serve to hold the backplate in place when mounted on the adapter. The backplate pins should always be placed pointing in a counter-clockwise direction so that the backplate does not slip. When handling the backplate be careful not to damage the contact surface of the mechanical seal or the front side of the backplate.

Since we have both standard stub shafts (6E) and stub shafts plus (6P) it is necessary to explain that the former are fixed onto the motor shaft with screws (6A) and the latter with screws that tighten a collar (92) onto the stub shaft. An explanation on how to place the stub shaft onto the motor follows.

Standard Stub Shaft - Before assembly, insert the set screws (6A) into the stub shaft (6E), leaving them loose so as not to penetrate the inner diameter. Then, place the key (provided with the motor) in the key-slot located on the shaft of the motor and smoothly slide the stub shaft onto the motor shaft. At this point, the stub shaft should easily slide on and off of the motor shaft and should freely spin, moving the motor shaft while in contact with the key. Place the backplate onto the adapter and turn it in a counter-clockwise direction, locking the backplate pins (11F) onto the adapter pins (71A). If necessary pull out the stub shaft so that it is still mounted onto the motor shaft. Place the retainer (24) into the stub shaft so that it recedes completely into its slot and insert the impeller onto the stub shaft, making sure that the retainer falls to one side to secure the impeller. Space the back of the impeller at a distance of 0.070 in. from the face of the backplate and tighten the set screws in order to secure the stub shaft.

Threaded Stub Shaft - The assembly process is the same as that of the standard stub shafts, except that in the case of the threaded stub shaft, you must first insert the impeller and tighten the castellated nut (24A). When the castellated nut can go no further, insert the cotter pin (24B) through the drilled hole in the stub shaft, so that it aligns with the slots on top of the castellated nut. Next, bend the ends of the cotter pin so that the castellated nut secures the impeller. Space the impeller at a distance of 0.070 inches from the backplate and tighten the set screws to secure the stub shaft. Please note that these stub shafts are not sanitary and do not meet 3A regulations.

AC+ Shaft - The AC+ stub shafts are secured by the friction between the motor shaft and stub shaft. This friction is created by the AC+ drive collar (92). As you tighten the screw (92A), the drive collar (92) exerts a force upon the stub shaft (6P) – which is slotted – forcing it to close. For ultimate efficiency, the three slots must be aligned as shown in figure B: 1 - the key slot on the motor shaft, 2 - the slot on the plus stub shaft, 3 - the slot on the drive collar. Slide the drive collar onto the stub shaft until it touches the stub shaft's larger diameter, and slide both parts onto the motor shaft aligning all three slots. You can use an Allen wrench less than 0.125inches to align the three slots. The motor shaft key is not used.

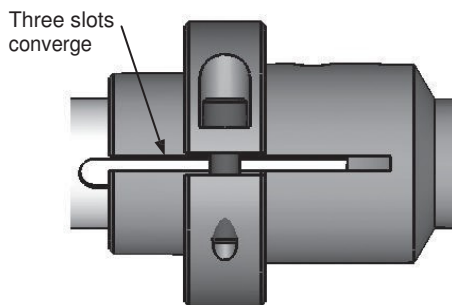

Figure B
AC+ Stub Shaft Assembly

BOLT TORQUES LISTED ON PAGE 9

Next, place the backplate onto the adapter (71) and turn it in a counter-clockwise direction, pressing it against the adapter so that the backplate pins (11F) lock onto the adapter pins (71A).

Place the impeller (2P) onto the stub shaft after placing the key (24C) into the key slot on the shaft. Screw on the impeller nut (24D) and tighten until it makes contact with the impeller using a socket (5/8" or 7/8" depending on the model).

Space the impeller at a distance of 0.070 in. from the face of the backplate and tighten the collar screw to set the stub shaft. When tightening the collar, be sure not to turn the shaft or the collar to avoid misalignment with the three slots.

IMPORTANT: At this point the adapter is mounted, the stub shaft is fixed on the motor, and the impeller is spaced at a distance of 0.070 inches from the backplate. Take off the impeller and remove the backplate to begin assembling the mechanical seal.

Place the deflector (40) in the ridge found on the standard stub shaft. Plus model stub shafts do not use a deflector.

Mechanical Seals

The “T21”, is used exclusively with our IC+ Series, specifically in non-sanitary applications.

The “D” is used when the fluid which is going to be pumped is neither corrosive nor abrasive. It is a balanced, external seal, designed to be long-lasting.

The “F” contains a water-cascade assembly to lubricate and cool the seal. The water-cascade assembly is located on one side of the adapter. This seal, although it is sanitary, is very dirty because the coolant tends to drip.

The “DG” seal consists of two parts: one stationary and one rotating. The stationary portion consists of a piece which may be carbon silicone, ceramic, or carbon tungsten, and that is placed in a gland ring. This type of seal is used when the fluid to be pumped is abrasive, corrosive, or contains a product which impedes the seal lubrication. The stationary seal reversible, so flipping the seal is sufficient to continue using it.

The “E” seal is a double-balanced seal cooled by water. This seal is composed of a stuffing box which is filled with fluid (normally water) to cool the mechanical seal. The “E” seal is used in conditions similar to those of the “DG” seal but in applications that handle extremely high temperatures (up to 500° F). It can also be used in applications where there exists a vacuum of up to 28 in. of mercury.

External-Balanced Seal Types “D” and “F” Locate the following pieces: carbon (80), o-ring (80B), “D” seal cup (80A), “D” seal spring (80C), “D” seal drive collar (80L), set screws (80K), and “D” seal backplate (11). Pre-assemble the set screws, making sure they do not penetrate the inner diameter of the stub shaft and set the o-ring into the carbon so that it sits at the back. Next, place the o-ring and carbon together onto the cup so that the cup’s three legs align with the carbon’s slots. Then, fit the spring onto the cup so that the tip of the spring is touching a fourth, folded leg on the cup. If necessary rotate the spring to touch the two pieces.

When handling the carbon (80), be careful not to bump or scratch the seat of the seal, as this is the face that makes the seal.

For best assembly, the drive collar has a pin or key that should fit into a slot in the cup. Use pressure to insert the drive collar, making sure that the pin aligns with the slot as shown in figure C.

Slide the entire assembly onto the stub shaft. The o-ring seals the flow of fluid between the pump and the exterior through the mechanical seal by filling the space between the stub shaft and carbon.

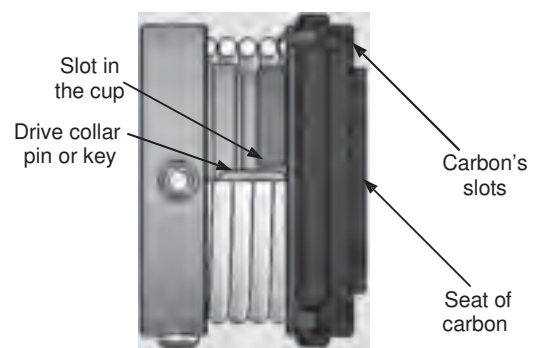

Figure C
Assembly Seal Type “D”

The seal will provide a resistance when it slides on, so apply pressure until it has gone onto the stub shaft completely. The position of the drive collar against the o-ring and carbon is critical to prevent leaks. Now, assemble the “D” seal backplate (11) and fix it with the backplate pins. Push the carbon back with the backplate.

Once the backplate has been placed it is necessary to tighten the “D” seal collar set screws (80L). To do this, you must exert a pressure on the drive collar towards the backplate, so that the pin of the drive collar remains aligned with the slot in the cup.

Tighten the set screws once the drive collar has reached its closest point to the o-ring and carbon.

The drive collar should stay in its place against the o-ring – against the back – within the limits of the carbon, as shown in figure D. The spring does not compress entirely.

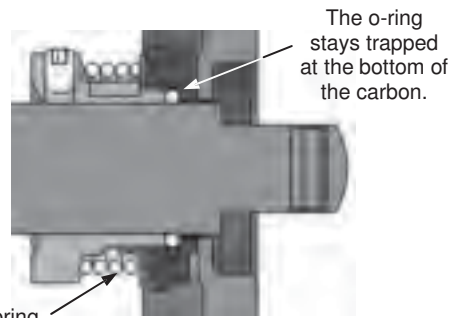

Figure D
Drive Collar Seal Type “D” Position

When all parts are in their correct positions, the stub shaft should be able to rotate freely when turned by hand. If it is necessary to use excessive force to turn the stub shaft, check to be sure that the components of the seal have been properly installed and that the drive collar is properly positioned.

The “**F SEAL**” The water-cascade assembly (132) should be installed on the adapter (71), so that the leak falls upon the seal seat of the carbon, lubricating the seal against the backplate.

IMPORTANT: It is necessary to disassemble some of the pump parts for cleaning and sterilizing. For those Ampco Pumps products equipped with “D” seals, if a CIP (Clean-in-Place) instillation is used, disassembly is not necessary. Do not lubricate the seal with grease or oil; the faces of the seals are lubricated by the fluid that is being pumped.

Clamped-In Seat Seal Type “DG” This seal type consists of two parts: a stationary and a rotating. The rotating part is the “D” seal assembly. For that reason it is highly recommended that you read the directions above for assembling the “D” seal before continuing. The stationary part consists of the following elements: “DG” seal seat (80N), PTFE gasket (80P), PTFE gasket (80R), “DG” gland ring (17J), lock washers (17M), bolts/screws gland ring (17K), and “DG” seal backplate (11H).

IMPORTANT: Be extra careful when assembling the “DG” seal. Incorrect spacing between the impeller and backplate can result in dangerous contact between the face of the stationary seal. That contact may wear down the impeller and the seat of the gland ring. A visual inspection following the installation of the impeller is recommended to check the spacing of the impeller and seal.

Take the “DG” backplate (11H), turn it around and place the PTFE gasket (80R) against the seat face. Next, install the seal seat (80N) – which is reversible – followed by the PTFE gasket (80P) and finally the gland ring (17J). In the seal type “DG”, the seal seat (80N) is enclosed by the gland ring, which could be made of silicone, tungsten, or ceramic. Please remember that the PTFE gaskets (80P) and (80R) are not interchangeable.

The seal seat (80N) should be handled with care, the material is extremely fragile. It is important to protect the faces of the stationary seal just as with the backplate, against bumps and scratches. Screw the gland ring into the backplate, using the screws (17K) and lock washers (17M). Screw the backplate pins (11F) to the backplate if applicable (figure E). Tighten the screws until the washers are flattened, any tighter and you may crack the stationary seal.



Figure E
Stationary Part Seal DG

Assemble the “D” seal components onto the stub shaft (as explained on page 12) taking care that the o-ring remains inside of the carbon. Once both pre-assemblies are complete, (the “DG” seal onto the backplate and that of the “D” seal), take the backplate and push on the “D” seal sliding it onto the stub shaft.

Be very careful not to hit the “DG” seal with the end of the stub shaft. Now, set the backplate onto the adapter. Although space appears to be limited, the spring can be compressed until the drive collar completely touches the o-ring.

Once the backplate is set onto the adapter, push the drive collar against the backplate to compress the spring. Tighten the set screws to set the seal when the spring no longer moves.

The efficiency of the “D” and “DG” seals relies upon the position of the o-ring inside the carbon as well as the full compression of the spring (Figure F).

The “DG” seal is used to handle fluids that crystallize when allowed to settle for a time. When pumping abrasive or corrosive fluids, combine the “DG” seal with EPDM gaskets.

EPDM gaskets are resistant to certain harsh chemicals. For more information, please contact either the plant or your distributor.

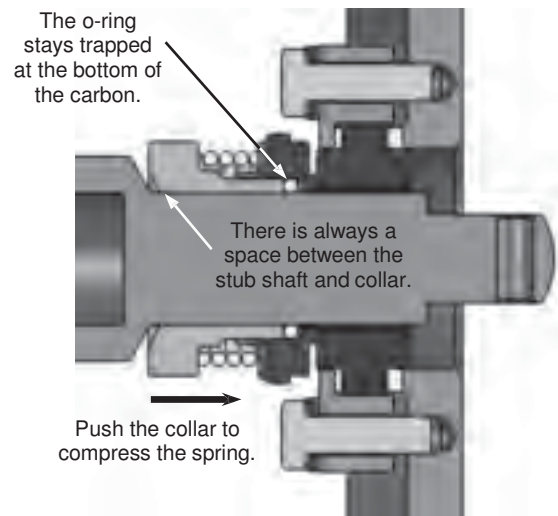

Figure F
Clamped-In Seat Seal Type “DG” Assembly

Water Cooled Balanced Double Seal Type “E”. This mechanical seal consists of two balanced, rotating parts, placed into a stuffing box, which is normally flooded to cool the seal.

The “E” seal consists of the following parts: stuffing box “E” (83C), o-ring (83E), machine screw (83D), follower (17), o-ring (17B), machine screw (17A), and lock washers (17C) for the follower, “E” seal backplate (11B), backplate pins (11F), spring (80H), drive collar “E” (80J), set screw drive collar (80M), two carbon seals (80), two o-rings (80B) and two cups (80G). It is recommended to have a caliper on hand to assemble this seal precisely.

The following instructions assume that the adapter is assembled and that the spacing between the impeller and backplate has been set. If not, we recommend you refer to that section of the assembly directions.

Place the o-ring (17B) in the groove of the collar (17). Attach the backplate pins (11F) to the backplate (11B), take the o-ring (83E) and place it in the slot of the stuffing box (83C) and place both parts against the backplate. Screw on the stuffing box (o-ring in place) to the backplate with the machine screw (83D). Be sure to protect the faces of the backplate during assembly. Pre-assemble the set screws (80M) onto the “E” drive collar (80J) without penetrating the inner diameter.

Slide the “E” drive collar, along with the o-ring, onto the stub shaft (6E), with the o-ring pointing towards the tip of the stub shaft. Pre-assemble the o-rings (80B) in the carbon seals (80), pushing them to the back of the seat. Place each carbon seal onto a cup (80G). These are the two rotating components that will be balanced on the spring (80H) inside the stuffing box (83C). Be very careful when handling the carbon seals, especially when handling the seal seat, because it is crucial in maintaining contact between the stuffing box and backplate.

Carefully slide the carbon seal, o-ring, and cup onto the stub shaft, using the “E” drive collar (80J) as a support for the o-ring. The seal seat of the carbon should be able to touch the follower (17). Slide the drive collar onto the stub shaft. Next, secure the drive collar to the stub shaft at the proper distance (Regardless of stub shaft model). For help, refer to Table A, which indicated the spacing values, then take the Vernier caliper and use it to measure that distance as shown in figure G.

Model	Distance X
114	0.621
216	0.572
218/328	0.610
4410	0.956

Table A.
Distance “X” for every models

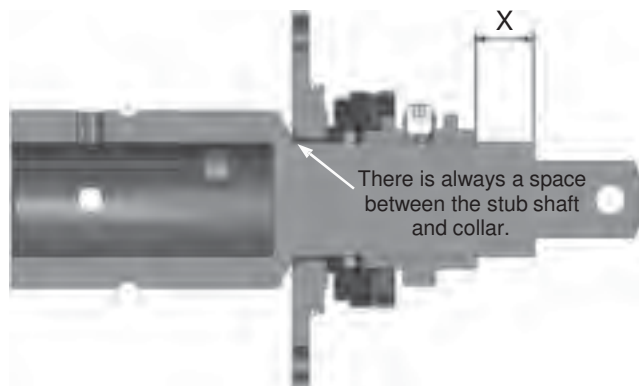

Figure G
Positioning of the drive collar type “E”

Locate the drive collar “E” (80J) and secure it with the set screws (80M). Place the spring (80H) onto the cup (80G). The drive collar has two pins, which drag both cups along the rotations of the stub shaft. Each cup has a folded leg that initiates traction with the drive collar. Try to place the pins before the legs of the cups, facing in a counter-clockwise direction (Figure H). Now, install the second set of the cup, o-ring, and carbon onto the stub shaft. Put the end of the spring into the second cup, just as you did with the first. The seal seat of the second carbon seal should point towards the backplate (11B). Take the sub-assembly of the backplate (11B) with the stuffing box (83C) and place it onto the adapter (71), making sure that the stuffing box does not hit the components mounted on the stub shaft. Push in and rotate the backplate until the pins are locked. If this model does not have backplate pins, place the casing gasket (90) into the slot on the backplate, put on the casing (1) and tighten using the clamp assembly (75) to secure the backplate.

IMPORTANT: When you mount the backplate onto the adapter, the seal may supply resistance. If this resistance is too much, check the seal assembly and be sure the drive collar has been located correctly. The efficiency of the “E” seal relies on the proper installation of the drive collar. The space in the stuffing box should contain both carbons in a balanced state of pressures and distances.

Figure I

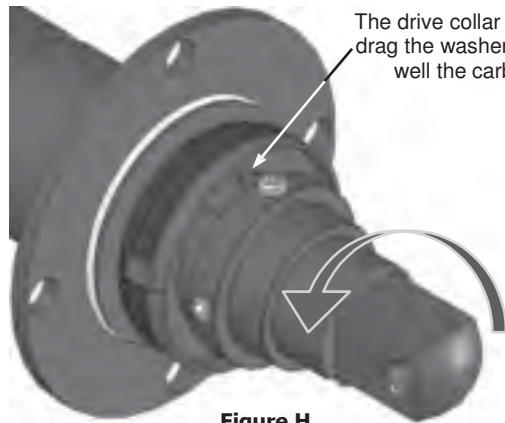

Figure H
The Stub Shaft turns Counter-Clockwise

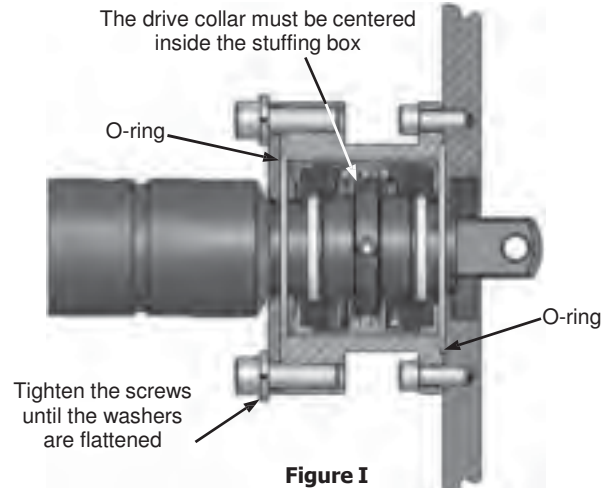

Figure I
Water Cooled Balanced Double Seal Type “E”

The next step is to close the stuffing box. To do so, you need to pull the follower against the backplate. Use the machine screws (17A) and lock washers (17C) to close it, tightening until the lock washers are flattened. The screws on a circular arrangement can be tightening across and varying positions when screwing.

It is recommended to set the backplate so that the 1/8 NPT drill-holes on the stuffing box, point upward and with a 45° inclination from the horizontal plane, as shown in Figure J.

The water should enter through one connection and leave through another, moving through the stuffing box and in the process, cooling it.

The ideal quantity of water will depend upon the temperature of your application. For vacuum applications it is recommended to use a flow of 10 drops per minute, while maintaining a temperature of 176° F inside the seal around 3 gallons per hour are required.

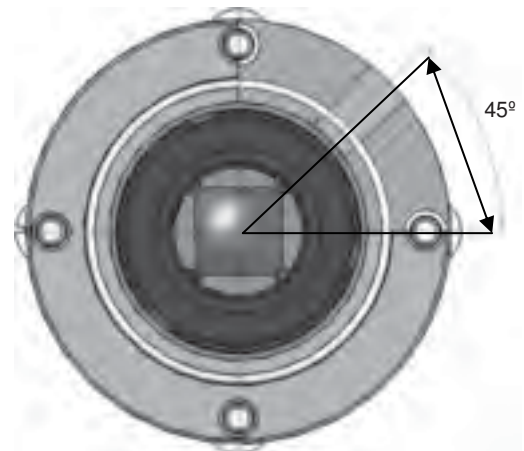

Figure J
Position of the 1/8 NPT drill-holes

IMPORTANT: When servicing pumps with “D”, “DG”, “F”, or “E” seals, inspect all disposable parts such as: carbon seals (be sure they have no bumps or scratches) and o-rings (they should maintain a circular form and should not be bitten). In the case of abrasive fluids, use EPDM material for all gaskets and o-rings. When dealing with high temperatures, use Viton. Springs are not subject to wear because of tension or compression, except in extreme cases. Carbon seals made of silicone, tungsten, or ceramic are very fragile but resist abrasive and corrosive fluids.

Conversion Kit Assembly

IMPORTANT: These instructions assume that the adapter has been mounted to the motor and the impeller has been spaced at a distance of 0.070 in. from the backplate. If you have not assembled the stub shaft, refer to the assembly section before proceeding. Remember that it is imperative you align the key slot on the motor shaft, the slot on the stub shaft, and the slot on the drive collar to properly mount the stub shaft, Figure B.

We can easily convert an AC Series standard pump to an AC+ Series pump with a conversion kit. The AC+ Series is 100% sanitary and meets the sanitary regulations set by 3A. The AC+ Series is an improved design that maintains a tighter, sturdier assembly.

To assemble a kit, you must first find the following components: drive collar plus (92), bolt drive collar (92A), stub shaft plus (6P), stub shaft key (24C), back impeller gasket (91A), front impeller gasket (91B), impeller plus (2P), and impeller nut (24D).

IMPORTANT: In some cases, the front and back gaskets are interchangeable (only models 218/328 and 4410).

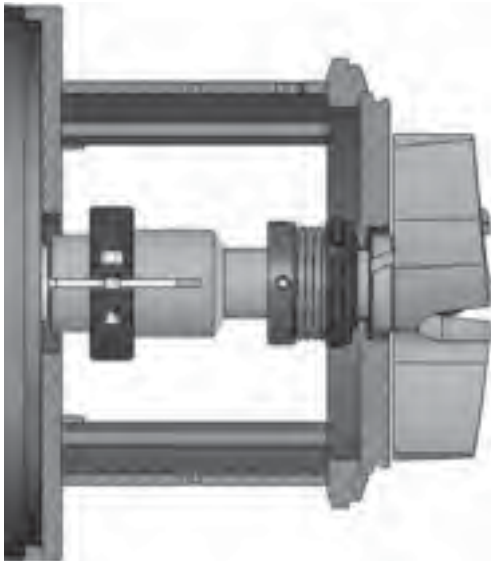

Figure K
Conversion Kit with Seal Type "D"

The conversion kit is compatible with "D", "DG", "F", and "E" seals. The only differences are the method of installing the stub shaft to the motor and the retention of the impeller, Figure K.

IMPORTANT: Before continuing with the assembly of the conversion kit put together the seal type that you are going to use.

Once you have put together the seal and secured the backplate, place the back gasket for the impeller plus (91A) into the groove on the stub shaft plus (6P). Next, place the shaft key (24C) into the key slot on the stub shaft. Slide the impeller plus (2P) onto the stub shaft and past the key, using the impeller key slot, making sure that the back gasket remains in its groove.

Insert the front impeller gasket (91B) into the groove on the impeller nut (24D). Screw the impeller nut onto the stub shaft making sure that the front gasket remains in the groove on the impeller nut.

Tighten using a socket (5/8" or 7/8", depending on the model) to assemble. Use a 3/8" diameter steel rod to secure the stub shaft when tightening.

The impeller nut should be tightened at 40 ft-lb, Figure L.

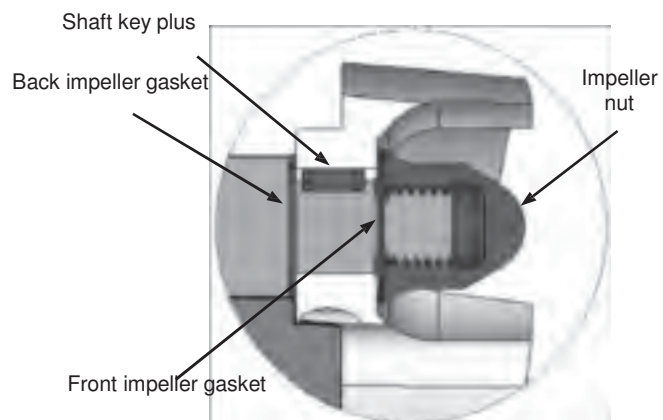

Figure L
Gaskets isolate the fluid from the thread and key

IMPORTANT: Never start the pump without the stub shaft key in place, as doing so may lead to friction between the impeller and stub shaft, causing seizure between the parts. Do not forget to adjust the screws and impeller nut before starting up the pump. If you are using CIP (Clean-in-Place) installations, there is no need to disassemble the AC+ conversion kit. The threads of the stub shaft and impeller nut are sealed from fluid entry by the front and back gaskets, and therefore are sanitary.

Industrial T21 Seal Assembly – IC+ Series

The IC+ series (industrial centrifugal pumps) is another configuration of the AC and AC+ Series designed for non-sanitary applications. The IC+ Series does not meet 3A sanitary regulations. An IC+ Series pump is composed of the same parts as a standard AC Series pump, but requires the conversion kit to set the stub shaft and install the impeller. It also uses an industrial internal seal – T21 – and a specially designed backplate. The T21 seal generally comes as a kit and is disposable, so if one of the parts is damaged you need to replace the entire kit.

IMPORTANT: These assembly instructions assume that the adapter has been mounted to the motor and the impeller has been placed at a distance of 0.070 in. from the backplate. If the stub shaft has not yet been assembled, please return to assembly section before continuing.

To assemble the T21 seal (95), please identify the following parts:

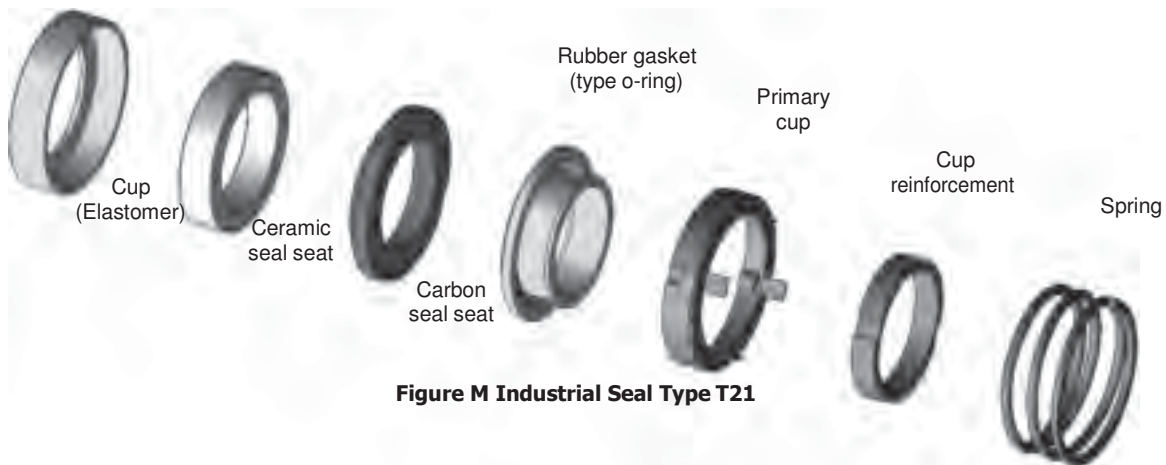



Figure M Industrial Seal Type T21

The ceramic seal, which is reversible, goes inside the elastomer cup, which gets inserted into the industrial backplate (11P). Place the reversible cup reinforcement into the primary cup so that the legs align with the slots. Place the rubber gasket (o-ring) into the primary cup so that it sits at the back and holds in the cup.

Now, place the carbon into the cup, taking care not to damage the seal seat, so that the carbon aligns with the groove in the cup. Place the backplate – with the ceramic seal seat in place – on the adapter, taking care not to bump the seal on the stub shaft threads.

Slide the sub-assembly of the carbon and cup onto the stub shaft until it touches the ceramic seal. Place the shaft key (24C) and back gasket (91A) in their respective slots. Force the spring into the cup and slide the plus impeller (2P) over the shaft key and onto the stub shaft and push. Place the front gasket (91B) in the groove on the impeller nut (24D) and tighten the assembly.

INSPECTION

	! WARNING
	<p>Before inspecting your pump's assembly, double-check that the electric supply is disconnected, and that there is no supply of pressure or fluid into the piping.</p>

Before continuing please check that all bolts/screws and set screws have been tightened. Rotate the stub shaft by hand, using the impeller. The stub shaft should rotate easily. If something is interfering with its rotation, inspect all parts to verify correct assembly (stub shaft, seal, backplate, etc.).

Impeller Retention

Standard Stub Shafts - Find the following parts: impeller (2), retainer (24), and standard stub shaft (6E). Place the retainer into the drilled hole atop the stub shaft so that it is completely recessed. When you have placed the impeller at the back, make sure that the retainer falls to lock in the impeller. Figure N.

Threaded Stub Shafts - Find the following parts: impeller (2), castellated nut (24A), threaded stub shaft (6F), and cotter pin (24B). Slide the impeller onto the tip of the stub shaft and push to the back. Screw on the castellated nut until it touches the impeller. Tighten more with the cotter pin in the grooves atop the castellated nut and bend back the ends of the pin to lock, Figure O.

AC+ Series - Find the following parts: impeller plus (2P), impeller gaskets (back 91A and front 91B), impeller nut (24D), shaft key (24C), and stub shaft plus (6P). Place the shaft key into the stub shaft and place the back impeller gasket (91A) into the groove on the shaft. Slide the impeller onto the shaft until it reaches the back and place the front gasket (91B) onto the impeller nut, screwing the nut (24D) onto the impeller. Make sure the gaskets stay in place, Figure P.

BOLT TORQUES-

Collars		Impeller Nuts	
56C/ 140TC/ 180 TC	15ft-lbs	AC+114	18ft-lbs
210TC/ 250TC	30ft-lbs	AC+216/ 218/328/ 4410	40ft-lbs
280TC/ 280TSC/ 320TC/ 320TSC	40ft-lbs		



Figure N
Standard stub shafts and
impeller pin



Figure O
Threaded stub shaft and
castellated nut



Figure P
Stub shaft plus and
Impeller nut

Casing Assembly

Once the impeller has been installed, the casing must be mounted. Place the casing gasket (90) onto the groove on the backplate (11, 11B, 11H or 11P), depending on the seal type. Take the casing (1) and place it onto the adapter, positioning the discharge at the desired location. Take the clamp assembly (75) and place it around the casing. Tighten the clamp to close the casing so that it is level around the perimeter. A rubber mallet may be helpful when installing the casing.

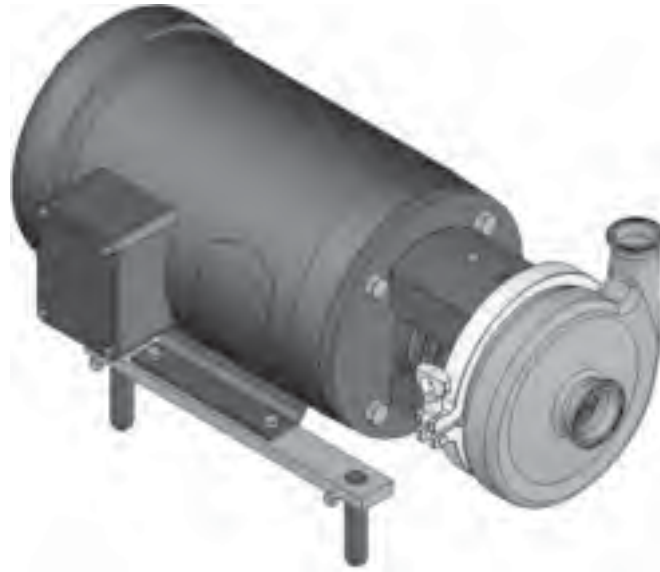

Pump Check

Check that the motor turns in a counter-clockwise direction. Keep the suction line flooded and the mechanical seal lubricated with the fluid which is going to be pumped. Never operate the pump dry or it may damage the seal. Maintain a sufficient NPSH available in the suction line (please see the section on piping).

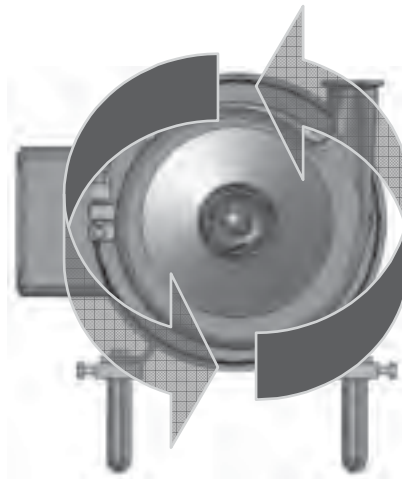

Troubleshooting

Ampco Pumps products are relatively easy to maintain with the exception of the sanitary process. Just as with any other element of machinery, problems may arise. This section offers a guide for identifying and correcting the majority of the pumping problems. For problems with you motor, contact the manufacturer directly for best assistance.

The following table illustrates the problems and probable causes, assuming that the pump was correctly selected for a specific application. If none of the listed solutions provided in the table resolves the problem, the most likely cause is cavitation.

Cavitation may be caused by an incorrect pump selection and its symptoms include: excessive noise, insufficient pressure, fluid leak, and vibration. If these symptoms are present, please re-evaluate your application.

1. NO FLOW	SOLUTIONS
<ul style="list-style-type: none"> a) Motor speed too low b) Incorrect rotation direction c) Obstruction in discharge piping or closed valves 	<ul style="list-style-type: none"> a) Check electric connections and motor b) Reverse one of the motors three phases, and if the direction does not change, contact the manufacturer c) Remove obstruction and open valves
2. INSUFFICIENT FLOW	
<ul style="list-style-type: none"> a) Motor speed too low b) Incorrect rotation direction c) Obstruction in discharge piping or closed valves d) Impeller damaged 	<ul style="list-style-type: none"> a) Check electric connections and motor b) Reverse one of the motors three phases, and if the direction does not change, contact the manufacturer c) Remove obstruction and open valves d) Replace impeller
3. EXCESSIVE POWER CONSUMPTION	
<ul style="list-style-type: none"> a) Motor speed too high b) Impeller damaged c) Motor shaft is bent or worn 	<ul style="list-style-type: none"> a) Motor wires are bad, replace motor b) Remove casing and replace impeller c) Replace motor shaft
4. EXCESSIVE NOISE	
<ul style="list-style-type: none"> a) Magnetic problem with motor b) Motor bearings damaged c) Foreign particles in impeller d) Impeller damaged e) Cavitation 	<ul style="list-style-type: none"> a) Consult motor manufacturer b) Replace bearings c) Remove casing and extract particles d) Replace impeller e) Check system's available NPSH
5. EXCESSIVE VIBRATION	
<ul style="list-style-type: none"> a) Pump is not leveled b) Impeller damaged c) Piping lacks supports d) Cavitation 	<ul style="list-style-type: none"> a) Level the pump b) Replace the impeller c) Support suction and discharge piping d) Check system's available NPSH
6. FLUID LEAK	
<ul style="list-style-type: none"> a) Disposable o-rings b) Disposable carbons c) Insufficient seal compression d) Damaged casing suction/discharge e) Disposable casing gasket f) Loose clamp assembly 	<ul style="list-style-type: none"> a) Replace o-rings b) Replace carbons c) Replace spring d) Replace casing e) Replace casing gasket f) Tighten clamp assembly

AMPCO PUMPS
Made of SELECTED corrosion-resistant alloys

TERMS AND CONDITIONS OF SALE

1. **ENTIRE AGREEMENT.** This document contains all of the terms and conditions of the agreement (“the agreement”) between Ampco Pumps Company, Inc. (“Seller”) and the purchaser (“Purchaser”) of the Products (“Products”) to be sold to Purchaser, to the exclusion of any other statements and agreements, and to the exclusion of any terms and conditions incorporated in Purchaser’s order or other documents of Purchaser. Seller’s acceptance of Purchaser’s order is expressly conditioned on Purchaser’s acceptance of the terms and conditions contained herein, and Purchaser, upon placing an order, is presumed to have accepted all the terms and conditions without modification. No alteration, waiver, modification or addition to the terms and conditions herein shall be binding on Seller unless set forth in writing and specifically agreed to by an officer of Seller. No course of dealing, usage of trade or course of performance will be relevant to supplement or explain any terms used in the agreement. All offers to purchase, quotations and contracts of sale are subject to final acceptance by Seller at its home office at Milwaukee, Wisconsin.
2. **PRICES.** Prices for Products manufactured by Seller pursuant to written accepted orders will remain firm for thirty (30) days from the date of any subsequent price change.
3. **TERMS OF PAYMENT.** Standard terms are ½% 10 days, 30 days net, from date of invoice unless otherwise stated. If, in the judgment of Seller, the financial condition of Purchaser at any time does not justify continuance of production or shipment on the terms of payment specified, Seller may require full or partial payment in advance. In cases of delays in payment, Seller reserves the right to charge interest on delinquent balances at the rate of 1 ½% per month.
4. **DELIVERY.** Except as otherwise provided expressly stated in the agreement, Products are sold F.O.B. Milwaukee. Seller will use reasonable commercial efforts to fill orders within the time stated, but the stated delivery date is approximate only, and Seller reserves the right to readjust shipment schedules without liability. Acceptance by Purchaser of the Products waives any claim for loss or damage resulting from a delay, regardless of the cause of the delay. Except as otherwise provided herein, Seller will not be responsible for freight, transportation, insurance, shipping, storage, handling, demurrage or similar charges. Claims by Purchaser for shortages in the Products must be made to Seller in writing within ten (10) days after date of receipt of the Products. No such shortage shall entitle Purchaser to withhold payment for Products which were received by Purchaser. Each such claim shall set forth in detail the basis and amount of such claim.
5. **TAXES AND FEES.** Seller shall pay all present and future sales, excise, privilege, use or other taxes, customs duties, and all other fees or other costs, imposed by any federal, state, foreign, or local authorities arising from the sale, purchase, transportation, delivery, storage, use or consumption of the Products or will, if applicable, provide Seller with an appropriate exemption certificate. Seller shall be under no obligation to contest the validity of any such taxes or to prosecute any claims for refunds or returns.
6. **INSTALLATION.** The Products shall be installed by and at the expense of Purchaser.
7. **LOSS, DAMAGE OR DELAY.** Seller will not be liable for loss, damage or delay resulting from causes beyond its reasonable control, including, without limitation, strikes or labor difficulties, lockouts, acts or omissions of any governmental authority or Seller, insurrection or riot, war, fires, floods, Acts of God, breakdown of essential machinery, accidents, embargoes, cargo or material shortages, delays in transportation, lack of production capacity or inability to obtain labor, materials or parts from usual sources. In the event of any such delay, performance will be postponed by such length of time as may be reasonably necessary to compensate for the delay. In the event performance by Seller under the agreement cannot be accomplished by Seller due to any of the foregoing causes within a reasonable period of time, Seller may, at its option, terminate the agreement without liability.
8. **RETURNS.** No Products or parts may be returned by Purchaser without the prior written consent of Seller.
9. **WARRANTY.** Seller warrants that the Products manufactured by Seller will be free from defects, material and workmanship under normal use and service for a period of one (1) year from date of shipment. In addition, the specified rating of each pump is warranted; however, the characteristic shape of the performance curves may vary from the published standards, and the capacity, head and efficiency guarantees are based on actual shop tests using clear cold water, and therefore the rating is specified in equivalent units of clear cold water. The sole obligation of Seller and the exclusive remedy of Purchaser for breach of this warranty shall be the repair (at Seller’s facility) or replacement by Seller (F.O.B. Milwaukee, Wisconsin), at Seller’s option, of any parts found to be defective, without charge and shall be conditioned upon Seller receiving written notice of any alleged breach of this warranty within a reasonable time after discovery of the defects, but in no event later than the end of the warranty period. The parts alleged to be defective shall be returned to Seller upon its request, freight prepaid. This warranty does not cover ordinary wear and tear, abuse, misuse, overloading, alteration or Products or parts which have not been installed, operated or maintained in accordance with Seller’s written instructions. Seller shall not be liable for any expenses for repairs, additions or modifications to the Products outside of Seller’s factory without its prior written consent, and any such repairs without such consent shall void this warranty. **THIS WARRANTY IS EXCLUSIVE AND IS IN LIEU OF ALL OTHER EXPRESS AND IMPLIED WARRANTIES WHATSOEVER, INCLUDING BUT NOT LIMITED TO IMPLIED WARRANTIES OF MERCHANTABILITY AND FITNESS FOR A PARTICULAR PURPOSE.** Seller may from time to time provide its facilities, personnel and experience to assist customers in the selection of materials, design, installation and operation of Products for maximum resistance to corrosion and abrasion with due consideration to the economy of the installation. This service is provided in an advisory capacity only and the final selection and operation of the Products and ancillary equipment shall be the sole responsibility of Purchaser or any user thereof. Accessories and parts manufactured by third parties are warranted only to the extent of such third party’s warranty. **IN NO EVENT SHALL SELLER BE LIABLE UNDER ANY CIRCUMSTANCES FOR ANY INCIDENTAL, CONSEQUENTIAL OR SPECIAL DAMAGES (INCLUDING, WITHOUT LIMITATION, ANY LOST PROFITS OR LABOR COSTS) ARISING FROM THE BREACH OF THIS WARRANTY OR OTHERWISE ARISING FROM OR RELATING TO THE PRODUCTS OR THEIR SALE, USE OR INSTALLATION.**
10. **CHANGES.** Changes in any work to be performed hereunder may be made only upon Purchaser’s written instructions and acceptance by Seller in its discretion. Any change in drawings, materials or design of the Products, or to tools, fixtures or other items used to produce the Products, which affects Seller’s cost to produce the Products will entitle Seller to adjust the price to take into account any additional costs. If work has been started, Seller shall be properly reimbursed for work already performed; if Products already produced are not accepted by Purchaser, Seller has the right to adjust the price to take into account any additional costs caused by an increase or decrease in quantities or in the time required for performance under the agreement.
11. **TERMINATION.** After Seller has commenced work, ordered any materials or made any other commitments pursuant to the agreement, it may be terminated only with the prior written agreement of Seller providing for equitable cancellation charges. Such charges shall reimburse Seller for any completed items at the contract price, and for any work-in-process items at the contract price less the cost to complete. Termination on any other basis must be specifically agreed on in writing in advance between Purchaser and Seller.

12. DEFERRED DELIVERIES. Orders or deliveries will be deferred only upon the prior written agreement of Seller in its discretion, and then only upon the following conditions:

(a) The deferral period may not exceed sixty (60) days. At the end of the deferral period, if no release is provided by Purchaser, Seller reserves the right to render an invoice for and ship the completed portion of the order to the destination specified in Purchaser's order, or to store such material at Purchaser's expense at Seller's standard storage charges then in effect.

(b) For the portion of the order that is not completed, if no release is provided by Purchaser at the expiration of the deferral period, Seller reserves the right to render an invoice for any completed items at the contract price, and for any work-in-process items at the contract price less the cost to complete.

(c) Purchaser shall bear the risk of loss or damage to materials held at Purchaser's request.

13. LIMITATION OF LIABILITY. IN NO EVENT SHALL SELLER BE LIABLE UNDER ANY CIRCUMSTANCES: (a) FOR ANY INCIDENTAL, CONSEQUENTIAL OR SPECIAL DAMAGES (INCLUDING, WITHOUT LIMITATION, ANY LOST PROFITS OR LABOR COSTS) ARISING FROM OR RELATING TO THE PRODUCTS OR THEIR SALE, USE OR INSTALLATION; (b) FOR DAMAGES TO PROPERTY (OTHER THAN THE PRODUCTS PURCHASED FROM SELLER); (c) FROM ANY BREACH OF ITS WARRANTY OR ANY OTHER OBLIGATIONS TO BUYER; OR (d) FOR ANY OTHER CAUSE WHATSOEVER, WHETHER BASED ON WARRANTY (EXPRESSED OR IMPLIED) OR OTHERWISE BASED ON CONTRACT, OR ON TORT OR OTHER THEORY OF LIABILITY, AND REGARDLESS OF ANY ADVICE OR REPRESENTATIONS (WHETHER OR NOT IN WRITING) THAT MAY HAVE BEEN RENDERED BY SELLER CONCERNING THE DESIGN, MANUFACTURE, SALE, USE OR INSTALLATION OF THE PRODUCTS.

14. INFRINGEMENT. Seller at its expense will defend and hold Purchaser harmless from and against all damages, costs and expenses arising from any valid claim of infringement by a third party with respect to any patent or other intellectual property rights (collectively, the "Intellectual Property Rights") caused by Products originally manufactured by Seller, provided Purchaser (a) has not modified such Products, (b) gives Seller immediate notice in writing of any claim or commencement or threat of suit, and (c) permits Seller to defend or settle the same, and gives all immediate information, assistance and authority to enable Seller to do so. In the event any such originally manufactured Products are held to infringe an Intellectual Property Right and if Purchaser's use thereof is enjoined, Seller will, at its expense and option: (1) obtain for Purchaser the right to continue using the Products, (2) supply non-infringing Products, (3) modify the Products so that they become non-infringing, or (4) refund the then market value of such Products. In no event shall Seller's liability exceed the sale price of the infringing Products. THE FOREGOING REPRESENTS SELLER'S ENTIRE AND EXCLUSIVE OBLIGATION WITH RESPECT TO ANY CHARGE OF INFRINGEMENT OF ANY INTELLECTUAL PROPERTY RIGHT AND IS IN LIEU OF ANY STATUTORY WARRANTY RELATING TO INFRINGEMENT. Notwithstanding the foregoing, Seller shall have no liability as to any Products or parts thereof that are manufactured or modified by Purchaser or a third party, or that are manufactured or modified by Seller in accordance with Purchaser's specifications. Purchaser will defend and hold Seller harmless from and against all damages costs and expenses whatsoever arising from any claim for infringement of any Intellectual Property Rights relating to Products that have been manufactured or modified by Seller according to specifications provided by Purchaser.

15. CERTAIN LAWS. Seller will comply with the applicable requirements of the Fair Labor Standards Act of 1938, as amended, Executive Order 11246, and THE rules, regulations and orders of the Secretary of Labor relating thereto.

16. PERIOD FOR ACCEPTING QUOTATIONS. Unless accepted without modification within thirty (30) days of issuance, or prior to withdrawal by Seller if earlier, all quotations automatically expire at the end of such thirty (30) day period.

17. PROVISIONS FOR INTERNATIONAL TRANSACTIONS. The following provisions shall apply if the Products are to be shipped to Purchaser at a location outside the United States, and apply regardless of other provisions set forth in these Terms and Conditions:

(a) The 1980 United Nations Convention on Contracts for the International Sale of Products shall not apply.

(b) Except as otherwise provided expressly stated in the agreement, terms of delivery are Ex-Works (within the meaning of INCOTERMS 2000) and all customs fees, import duties, cargo insurance, taxes and other charges imposed on or relating to the purchase or sale of the Products shall be paid by Purchaser in addition to the stated price.

(c) Except as otherwise provided expressly stated elsewhere in the agreement, payment shall be made by issuance to Seller of an irrevocable letter of credit which (i) is issued and confirmed by a U.S. bank acceptable to Seller, (ii) is governed by the Uniform Customs and Practice for Documentary Credits (UCP 600) and otherwise acceptable in form and substance to Seller, and (iii) provides for payment to Seller of the purchase price in U.S. dollars upon presentation by Seller of Seller's certification and/or such other documents as shall be required by the letter of credit. All banking and other charges for such letter of credit shall be for the account of Purchaser.

(d) Prices include Seller's standard commercial export packaging which may vary depending on whether shipment is made by air, land or sea. Except as otherwise provided expressly stated in the agreement, Purchaser will bear any additional expenses required to satisfy Purchaser's packaging requirements. Packages will be marked in accordance with Purchaser's instructions, if any. Seller shall furnish packing lists and such other information as may be necessary to enable Purchaser's agent to prepare documents required for export shipment.

(e) All shipments hereunder are subject to compliance with the U.S. Export Administration Act, as amended, regulations thereunder and all other U.S. laws and regulations concerning exports. Purchaser shall comply with all such laws and regulations concerning the use, disposition, re-export and sale of the Products provided hereunder.

18. GENERAL. No modification or waiver of the agreement or any of its provisions is valid unless expressly agreed to by Seller in writing, and no waiver by Seller of any default under the agreement is a waiver of any other or subsequent default. The unenforceability or invalidity of one or more of the provisions of the agreement will not affect the enforceability or validity of any other provision of the agreement. Purchaser may not assign any of its rights, duties or obligations under the agreement without Seller's prior written consent and any attempted assignment without such consent, even if by operation of law, will be void. The agreement is governed by and shall be construed in accordance with the laws of the State of Wisconsin, including the Uniform Commercial Code as enacted by such state, without giving effect to its conflict of laws principles.

Ampco Pumps Company Return Policy

This policy is intended for returns that are not covered by product warranty, i.e. wrong pump or part was ordered, customer canceled order, etc. Before returning any product, contact us for a Returned Material Authorization Number (RMA#). This will eliminate confusion when the parts are received and facilitate processing the return. No action will be taken on returned parts without an RMA.

<u>Type of Return</u>	<u>Restocking Charge</u>
Standard pump with a replacement order	10%
Standard pump without a replacement order	15%
Standard parts with a replacement order	5%
Standard parts without a replacement order	10%

Additional restocking charges may be assessed for any of the following circumstances.

1. Special order motors and seals are not returnable unless we have a use for them. Credit will be determined on a case-by-case basis.
2. Impellers that are trimmed to a diameter that we don't regularly use are not returnable. Credit will be determined on a case-by-case basis.
3. Used seals and motors are not returnable.

Credits

Credit will be issued only after parts are returned and inspected. Customer is responsible for packaging parts so they are returned in "as new" condition. Any labor required by Ampco to return the parts to "as new" condition will be deducted from the credit.

Ampco Pumps Company
2045 W. Mill Road
Glendale, WI 53209
Phone: (800) 737-8671 or (414) 643-1852
Fax: (414) 643-4452
Email: ampcoacs@ampcopumps.com

