

Ampco Centrifugal Pumps

DATA SHEET

MODEL ZCM/ZCHM 1½X1½

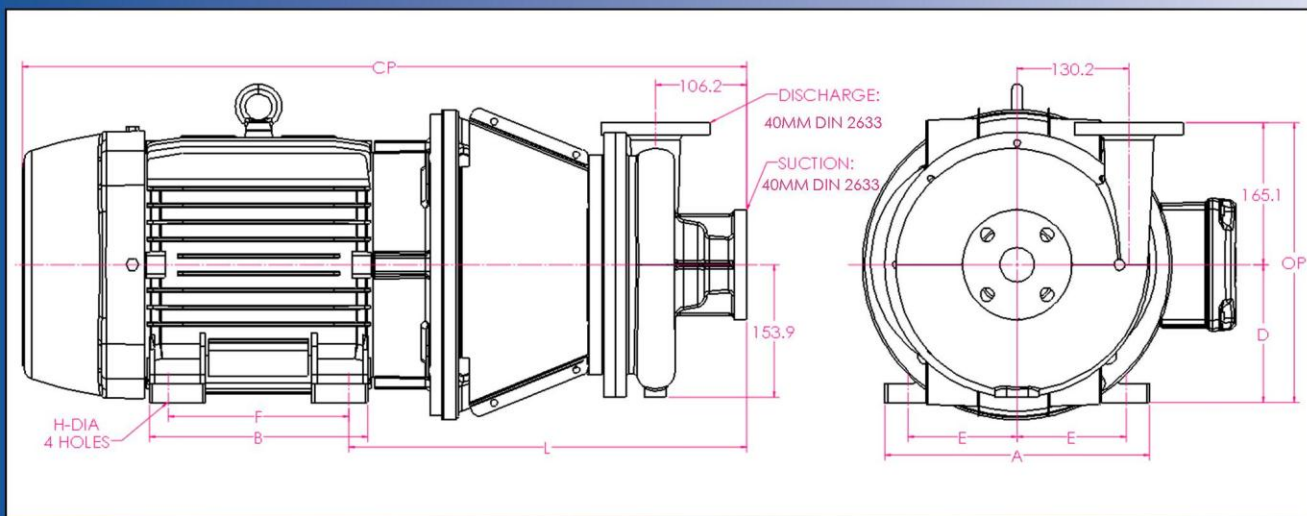
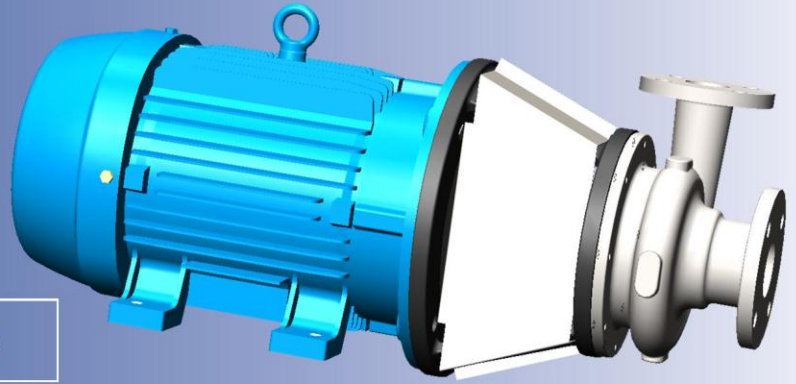

IEC MOTOR		DIMENSIONS IN MM (For Reference Only)									APPROX. WEIGHT (KG)
FRAME	KW/RPM	A (max)	B (max)	D	E	F	H	L	CP	OP	
80	0.75/1450; 0.75/2900; 1.1/2900	155.1	124.0	80.0	65.6	100.0	10.0	310.5	495.0	245.1	61.3
90S	1.1/1450; 1.5/2900	169.4	144.9	90.0	70.0	100.0	10.0	313.5	537.0	255.1	63.1
90L	1.5/1450; 2.2/2900	169.4	144.9	90.0	70.0	125.0	10.0	313.5	537.0	255.1	66.3
100L	2.2/1450; 3/2900	196.0	170.0	100.0	80.0	140.0	12.0	334.9	588.0	265.1	70.4
112M	4/1450; 4/2900	220.0	177.0	112.0	95.0	140.0	12.0	341.9	606.0	277.1	85.8
132S	5.5/1450; 5.5/2900; 7.5/2900	248.0	187.0	132.0	108.0	140.0	12.0	401.0	682.6	297.1	124.9
132M	7.5/1450	248.0	187.0	132.0	108.0	178.0	12.0	401.0	682.6	297.1	124.9
160M	11/1450; 11/2900; 15/2900	308.0	254.0	160.0	127.0	210.0	14.5	463.0	843.0	325.1	176.6
160L	15/1450; 18.5/2900	308.0	254.0	160.0	127.0	254.0	14.5	463.0	843.0	325.1	176.6

MATERIAL SPECIFICATIONS

PART NAME	NICKEL ALUMINUM BRONZE	STAINLESS STEEL
Casing, Cover & Impeller	AMPCO® 483	316 Stainless
Wear Ring	AMPCO® 18	316 Stainless
Motor Shaft	Steel	Steel
Shaft Sleeve	AMPCO® 18	316 Stainless
Adapter	Cast Iron	Cast Iron

* Also available in Duplex 2205

Ampco Centrifugal Pumps

MODEL ZCM 1½X1½

Curves show approximate characteristics
Based on clear 20° water.
Rated point is guaranteed.

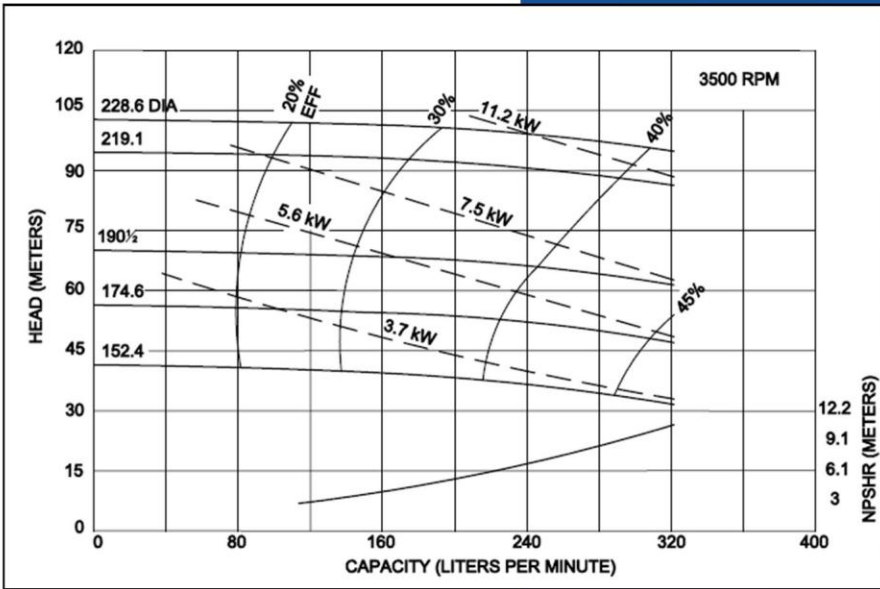

Heavy-duty Z Series pumps
have maximum wall
thickness and Din PN10
flanged connections.

Seal options include Type
21, Type 1 and Type 9 with
choice of sealing materials.

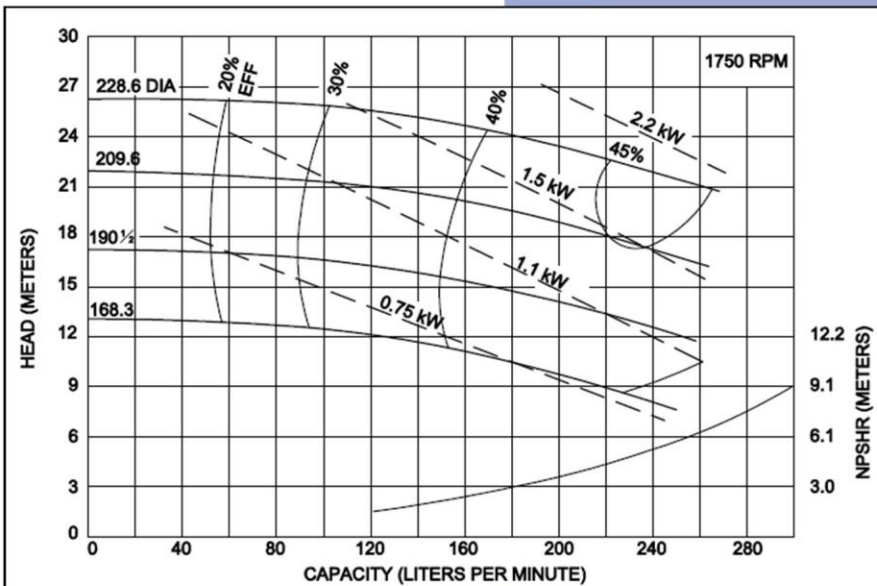
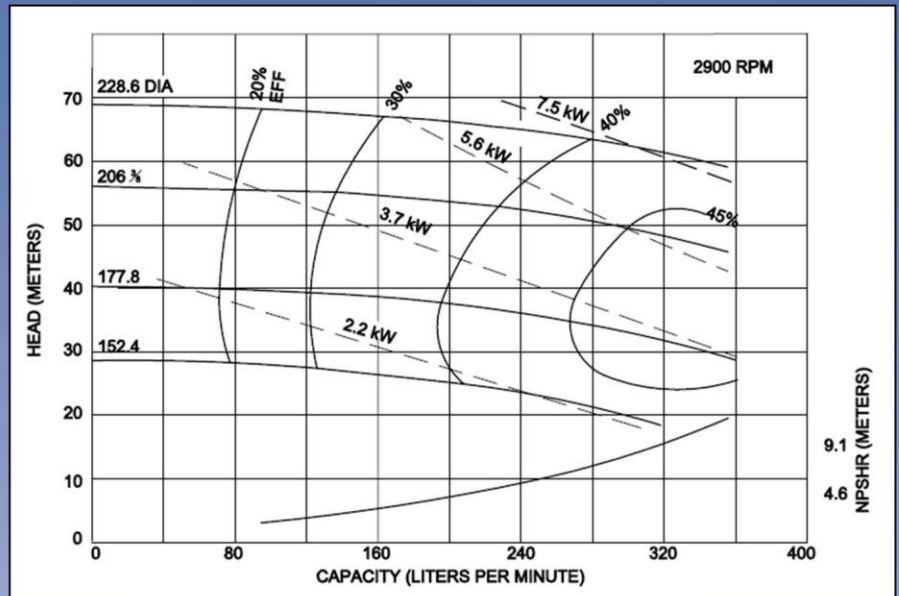

Ampco Pumps Company

2045 West Mill Road
Glendale, WI 53209
Phone: (414) 643-1852
Fax: (414) 643-4452