

# Ampco Centrifugal Pumps

## DATA SHEET

MODEL ZCM 1½X1¼  
NICKEL ALUMINUM BRONZE

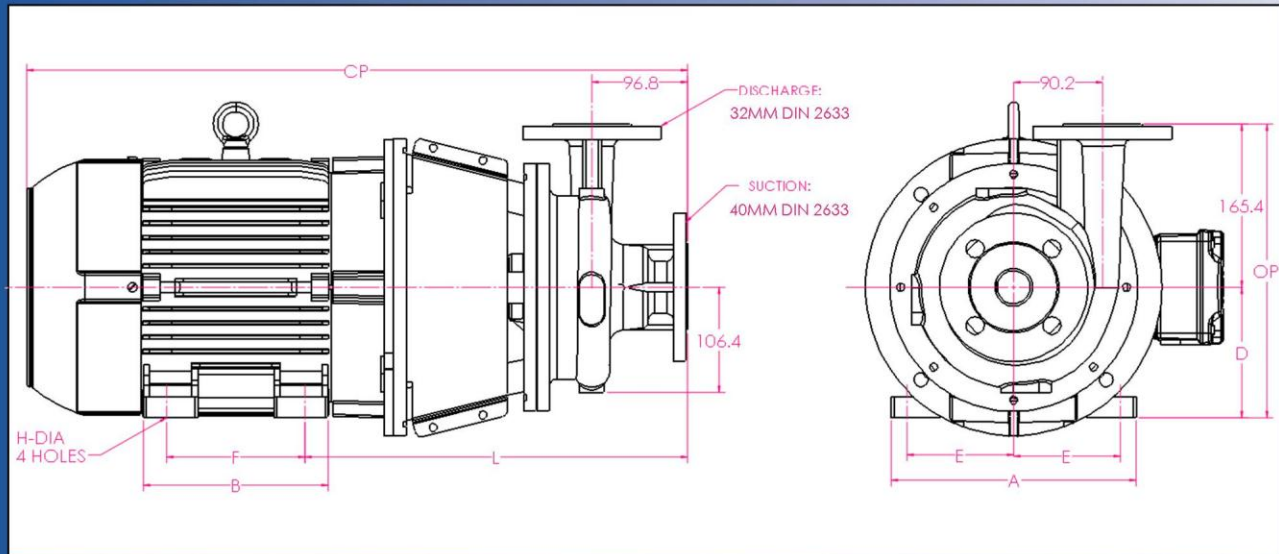
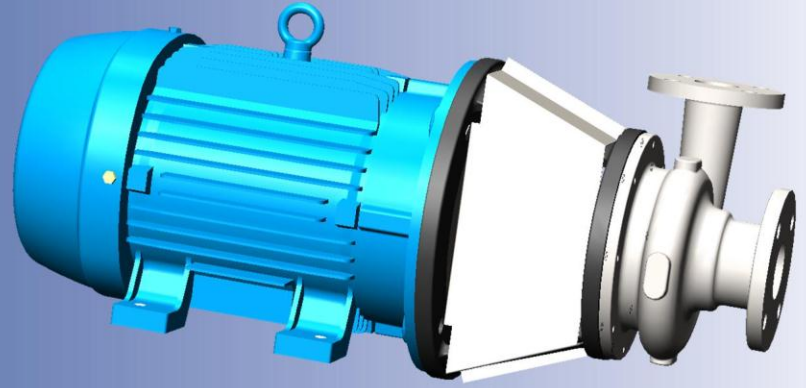

IEC MOTOR		DIMENSIONS IN MM (For Reference Only)									APPROX. WEIGHT (KG)
FRAME	KW/RPM	A (max)	B (max)	D	E	F	H	L	CP	OP	
80	0.75/1450; 0.75/2900; 1.1/2900	155.1	124.0	80.0	65.6	100.0	10.0	296.9	481.35	245.2	49.9
90S	1.1/1450; 1.5/2900	169.4	144.9	90.0	70.0	100.0	10.0	299.9	523.4	255.2 3	51.7
90L	1.5/1450; 2.2/2900	169.4	144.9	90.0	70.0	125.0	10.0	299.9	523.4	255.2 3	54.4
100L	2.2/1450; 3/2900	196.0	170.0	100.0	80.0	140.0	12.0	321.3	574.3	265.2	66.2
112M	4/1450; 4/2900	220.0	177.0	112.0	95.0	140.0	12.0	328.3	592.3	277.2	72.1
132S	5.5/1450; 5.5/2900	248.0	187.0	132.0	108.0	140.0	12.0	387.3	668.9	297.2	103.0

## MATERIAL SPECIFICATIONS

PART NAME	NICKEL ALUMINUM BRONZE	STAINLESS STEEL
Casing, Cover & Impeller	AMPCO® 483	316 Stainless
Wear Ring	AMPCO® 18	316 Stainless
Motor Shaft	Steel	Steel
Shaft Sleeve	AMPCO® 18	316 Stainless
Adapter	Cast Iron	Cast Iron

\* Also available in Duplex 2205

# Ampco Centrifugal Pumps

**MODEL ZCM 1½x1¼  
NICKEL ALUMINUM BRONZE**

Curves show approximate characteristics  
Based on clear 20° water.  
Rated point is guaranteed.

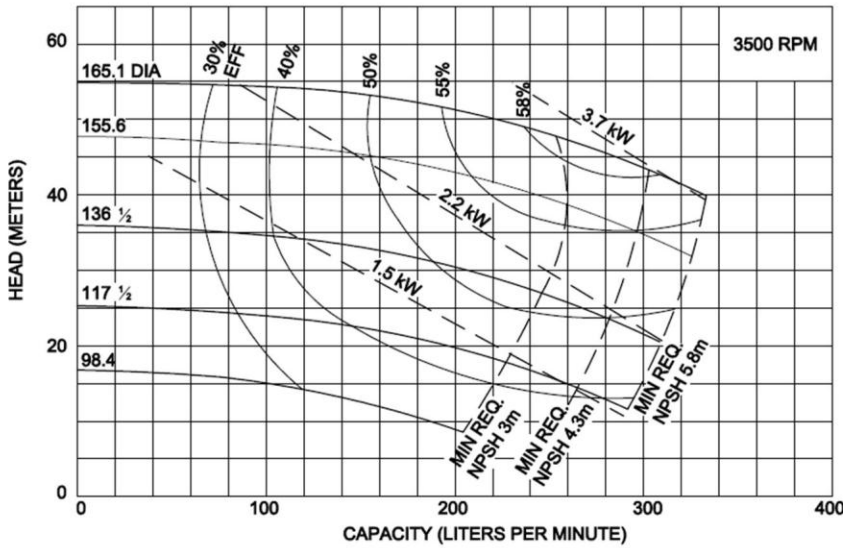

Heavy-duty Z Series pumps  
have maximum wall  
thickness and Din PN10  
flanged connections.

Seal options include Type  
21, Type 1 and Type 9 with  
choice of sealing materials.

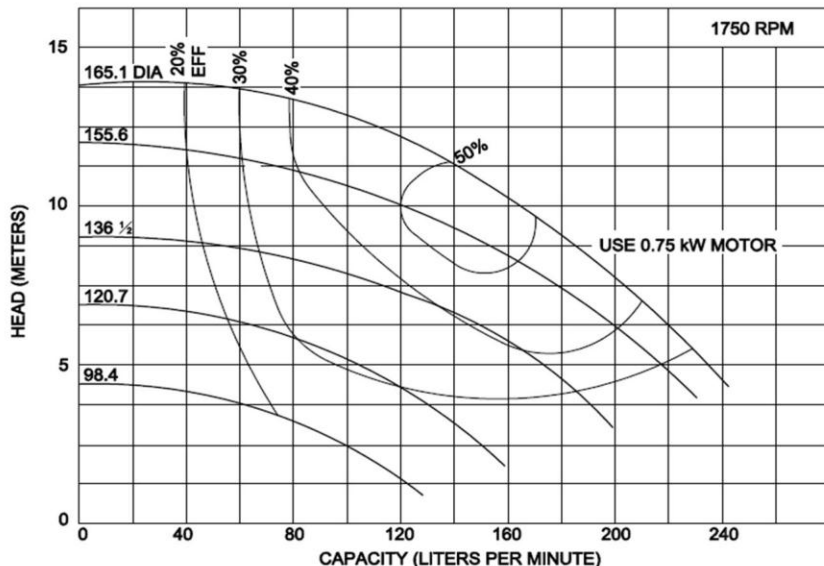
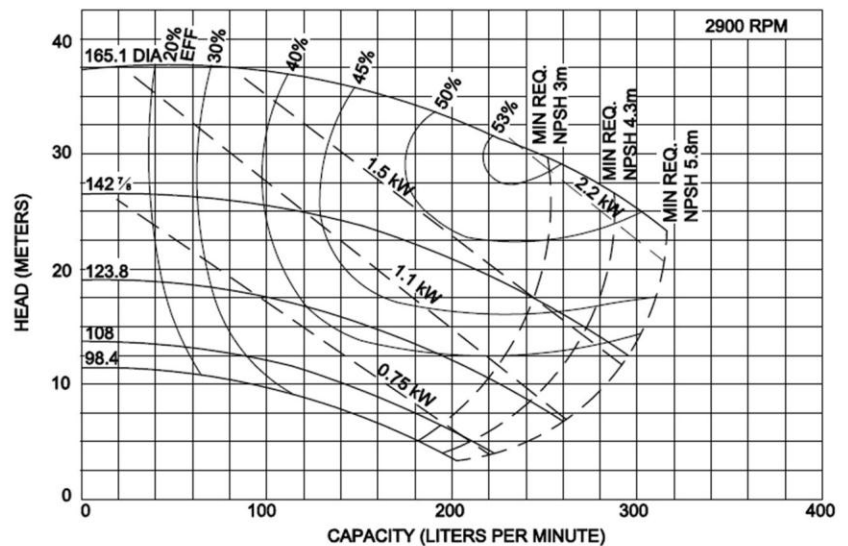

## Ampco Pumps Company

2045 West Mill Road  
Glendale, WI 53209  
Phone: (414) 643-1852  
Fax: (414) 643-4452

