

# Ampco Centrifugal Pumps

DATA SHEET

MODEL ZC2/ZCH2 5x4

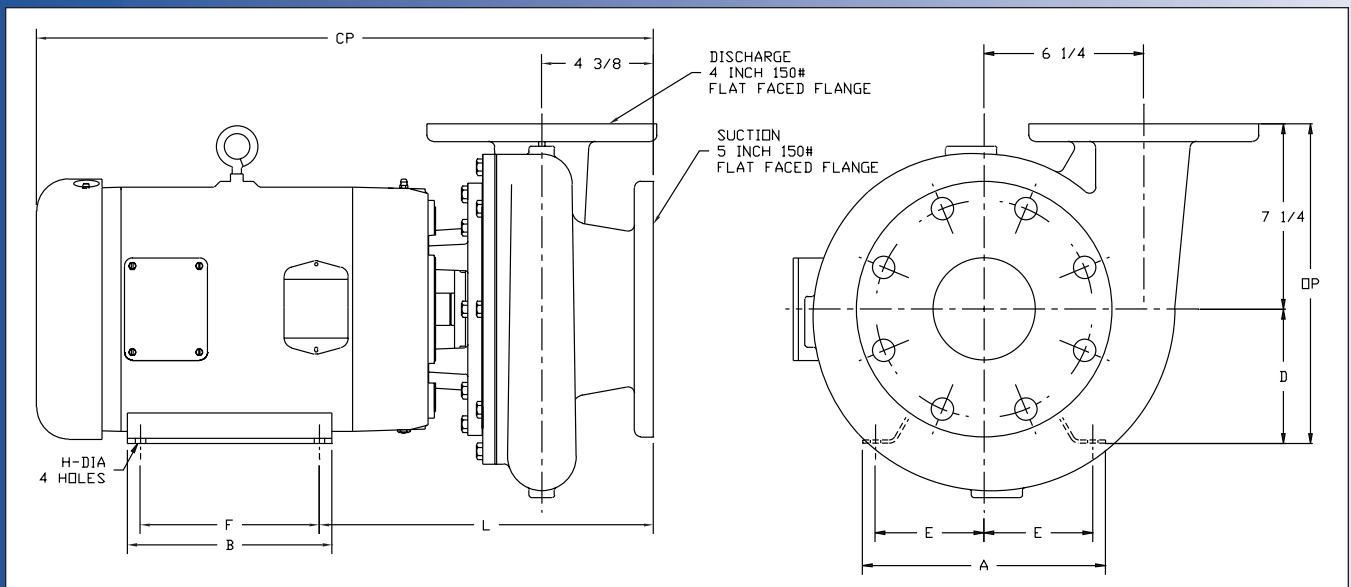
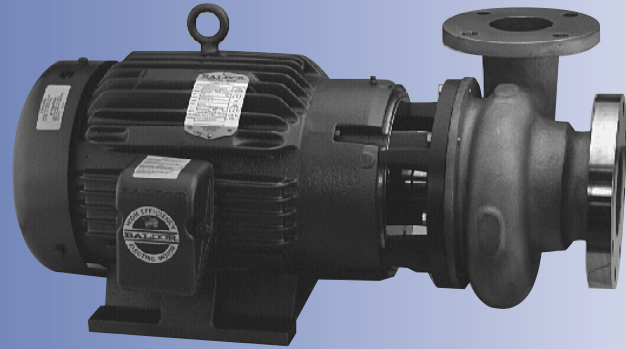

TEFC MOTOR			DIMENSIONS IN INCHES (For Reference Only)									APPROX. WEIGHT (LBS)
HP	RPM	FRAME	A (typ)	B (typ)	D	E	F	H	L	CP	OP	
7-1/2	1750	213JM	9-1/2	8	5-1/4	4-1/4	5-1/2	13/32	13-3/32	24-1/8	12-1/2	296
10	1750	215JM	9-1/2	8	5-1/4	4-1/4	7	13/32	13-3/32	25-5/16	12-1/2	314
15	1750	254JM	11-1/2	9-3/4	6-1/4	5	8-1/4	17/32	14-11/32	27-7/16	13-1/2	477
20	1750	256JM	11-1/2	11-1/2	6-1/4	5	10	17/32	14-11/32	29-1/2	13-1/2	525

## MATERIAL SPECIFICATIONS

PART NAME	NICKEL ALUMINUM BRONZE
Casing, Cover & Impeller	AMPCO® 482
Wear Rings	AMPCO® 18
Motor Shaft	Steel
Shaft Sleeve	AMPCO® 18
Adapter	Cast Iron

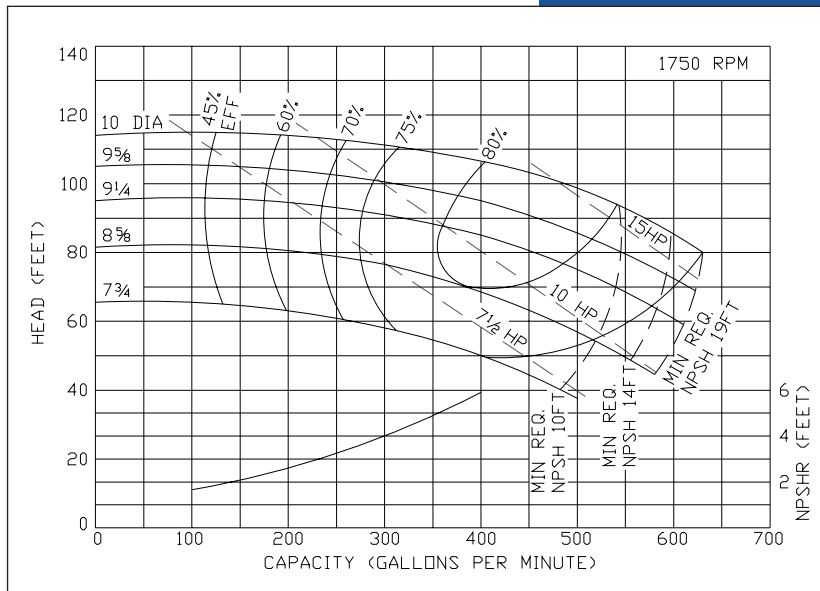

# Ampco Centrifugal Pumps

## MODEL ZC2/ZCH2 5x4

Curves show approximate characteristics based on clear 68° water. Rated point is guaranteed.

Heavy-duty Z Series pumps have maximum wall thickness and 150 lb. flat faced flanged connections.

Seal options include Type 21, Type 1 and Type 9 with choice of sealing materials.

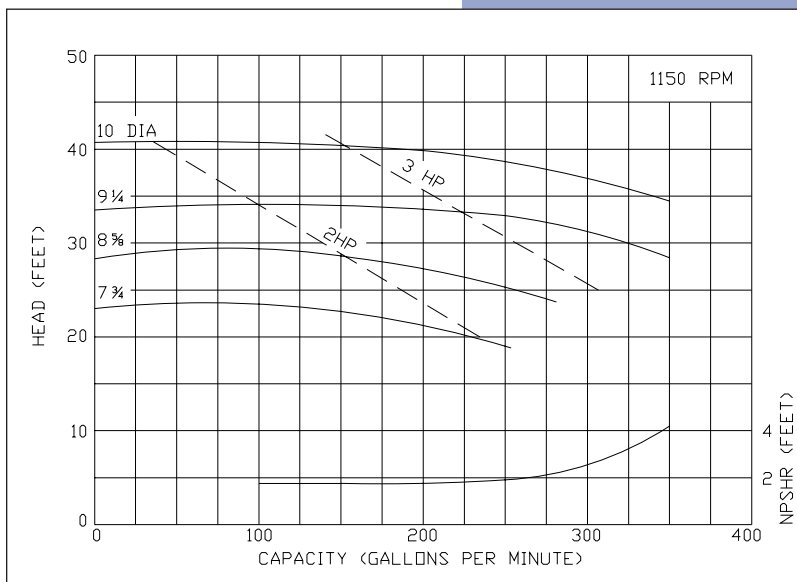
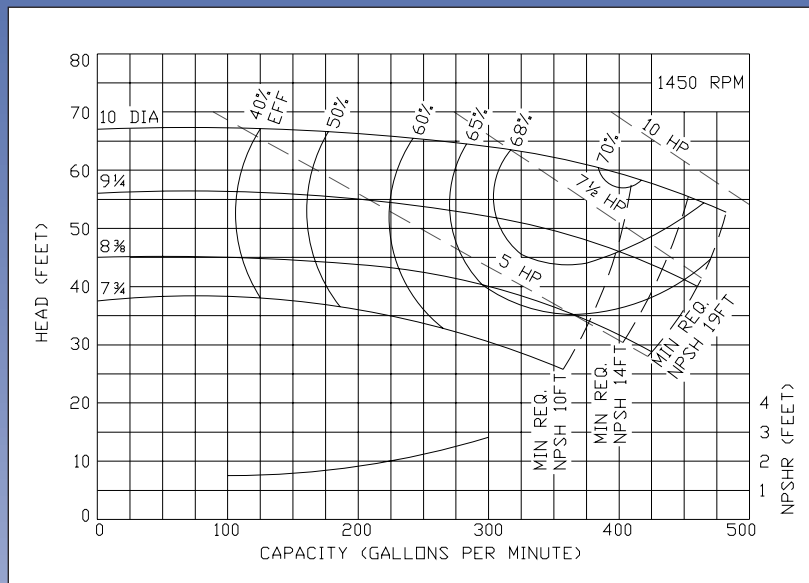

# Ampco Pumps Company

4424 West Mitchell Street  
 Milwaukee, Wisconsin 53214  
 PHONE (414) 643-1852  
 FAX (414) 643-4452