

# Ampco Pumps Company

## ZP1+

### AMPCO ZP1+ DESIGN

- Available in models 30-220
- Patented design. O-rings are located at the front of the body and the sleeve is now a mating part of the rotor.
- O-rings can be changed without having to disconnect the pump from the piping system.
- Secondary sleeve/spring assembly will seal the pump if the rotors are removed for CIP processing.

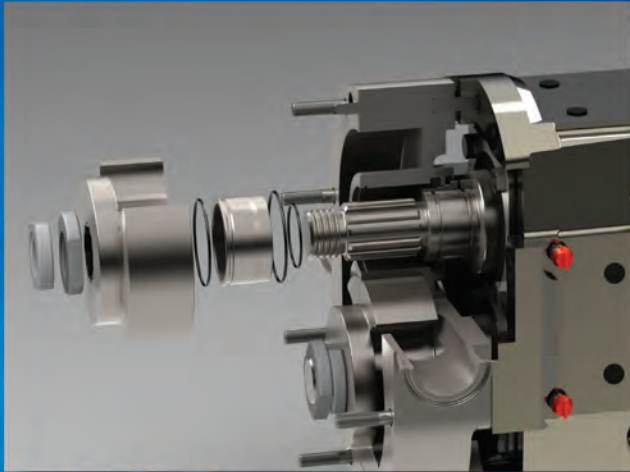

### REMANUFACTURING OPTION

Existing ZP1 pumps (and competing models) can be converted to a ZP1+ pump during the remanufacturing process at no extra charge.

# Ampco Innovations

REDUCED DOWNTIME, EASY TO MAINTAIN  
CLEAN-IN-PLACE

## ZP3

### AMPCO ZP3 DESIGN

- Patented front-loading seal design for ease of maintenance
- ZP3 seal design eliminates all dead zones in the pump and is fully CIP-able without modifications
- 3-A and EHEDG certified
- Tungsten carbide versus silicon carbide seal faces offer longer life

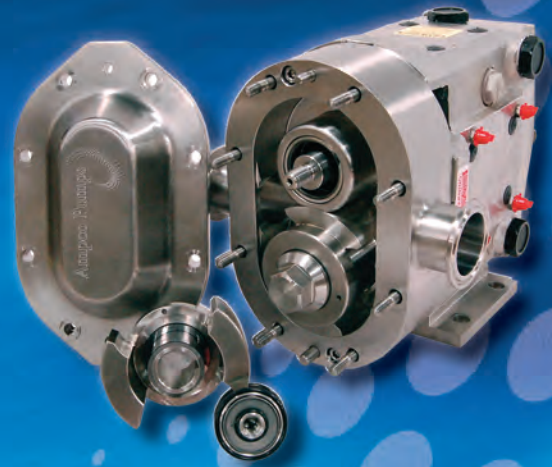

### REMANUFACTURING OPTION

Existing ZP2 pumps (and competing models) can be converted to a ZP3 with new rotors, seals and re-machining the existing rotor case.

### Only Ampco ZP pumps offer all of these upgrades at no additional charge

- Stainless steel gearcase on new pumps
- Stainless steel retainers
- 17-4 PH stainless steel shafts
- Helical Gears
- 4-way mounting
- Sealed cleanout plugs
- 6 oil fill plugs with sight glass
- 2-side threaded grease zerks

Ampco Pumps Company  
2045 W. Mill Road  
Glendale, WI 53209  
AmpcoPumps.com  
sales@ampcopumps.com  
800.737.8671

Ampco Pumps Company

Ampco Pumps GmbH  
AM Gaxwald 6  
76863 Herxheim Germany  
AmpcoPumps.de  
info@ampcopumps.de  
+49 7276 5058515