

# Ampco Centrifugal Pumps

## DATA SHEET

MODEL IC+ 1 1/2 X 1 1/2

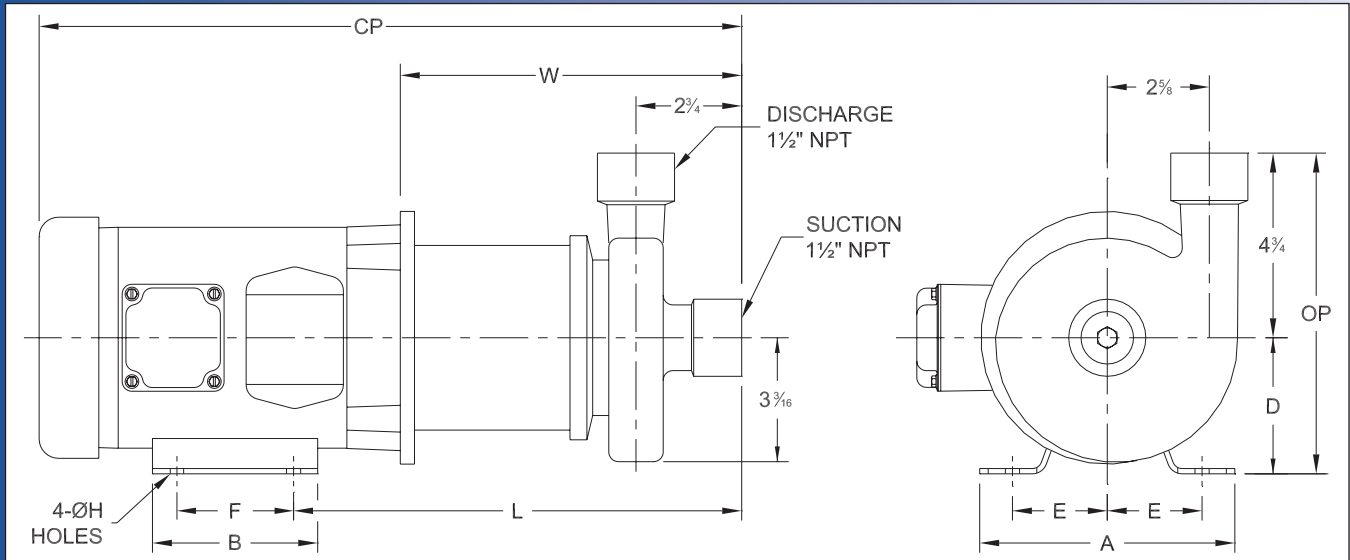
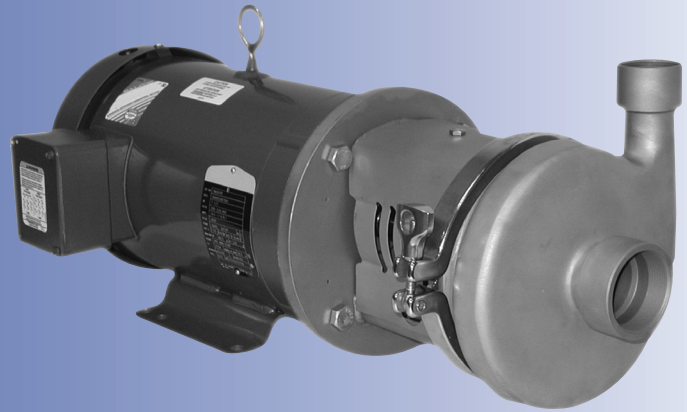

TEFC MOTOR			DIMENSIONS IN INCHES (For Reference Only)										APPROX WEIGHT (LBS)
HP	RPM	FRAME	A (typ)	B (typ)	D	E	F	ØH	L	W	CP	OP	
1/4	1750	56C	6-9/16	4-1/4	3-1/2	2-7/16	3	7/16	11-9/16	8-13/16	18-1/16	8-1/4	20
1/2	1750	56C	6-9/16	4-1/4	3-1/2	2-7/16	3	7/16	11-9/16	8-13/16	18-1/16	8-1/4	20
1/2	1750	56C	6-9/16	4-1/4	3-1/2	2-7/16	3	7/16	11-9/16	8-13/16	18-1/16	8-1/4	41
3/4	3500	56C	6-9/16	4-1/4	3-1/2	2-7/16	3	7/16	11-9/16	8-13/16	18-1/16	8-1/4	42
1	3500	56C	6-9/16	4-1/4	3-1/2	2-7/16	3	7/16	11-9/16	8-13/16	18-1/16	8-1/4	44
1-1/2	3500	56C	6-9/16	4-1/4	3-1/2	2-7/16	3	7/16	11-9/16	8-13/16	19-1/16	8-1/4	59
1-1/2	3500	143TC	6-1/2	6	3-1/2	2-3/4	5	11/32	11-9/16	8-13/16	20-1/16	8-1/4	59
2	3500	56C	6-9/16	4-1/4	3-1/2	2-7/16	3	7/16	11-9/16	8-13/16	19-1/16	8-1/4	73
2	3500	145TC	6-1/2	6	3-1/2	2-3/4	5	11/32	11-9/16	8-13/16	20-1/16	8-1/4	66
3	3500	145TC	6-1/2	6	3-1/2	2-3/4	5	11/32	11-9/16	8-13/16	20-1/16	8-1/4	75
5	3500	184TC	8-5/8	6-1/2	4-1/2	3-3/4	5-1/2	13/32	12-15/16	9-7/16	24-9/16	9-1/4	98

## MATERIAL SPECIFICATIONS

PART NAME	STAINLESS STEEL
Casing	316L Stainless
Backplate, Impeller, Stub Shaft	316L Stainless
Adapter	304 Stainless



# Ampco Centrifugal Pumps

MODEL IC+ 1 1/4 1 1/2 X 1 1/2

Curves show approximate characteristics  
based on clear 68° water.  
Rated point is guaranteed.

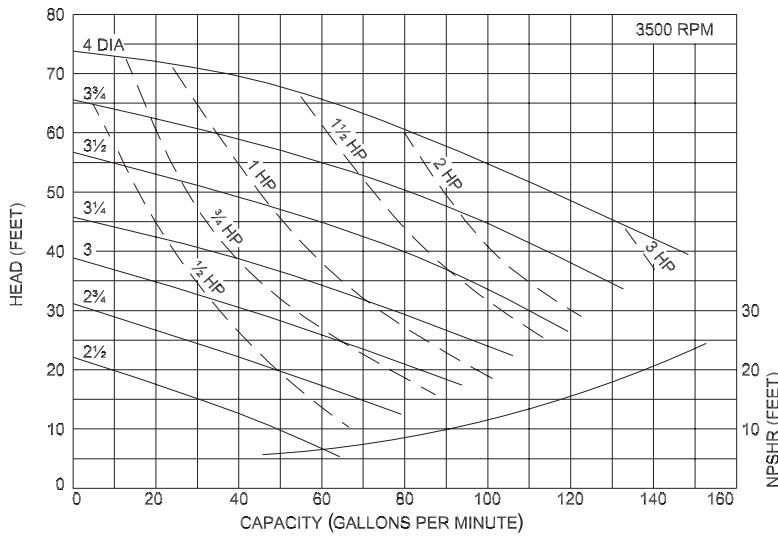

IC+ Series pumps have standard NPT connections.

Flange connections are optional.

IC+ pumps are constructed of 316L stainless steel  
with a glass beaded finish.

The standard IC+ mechanical seal is a Type 21  
with a ceramic seat, carbon rotating element.  
Buna-N elastomers and 304 SS metallics.

Contact the factory for other seal  
material options.

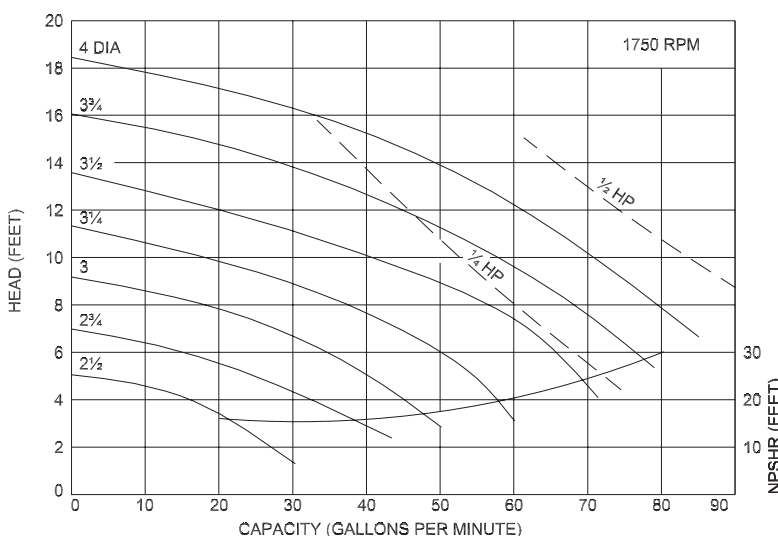
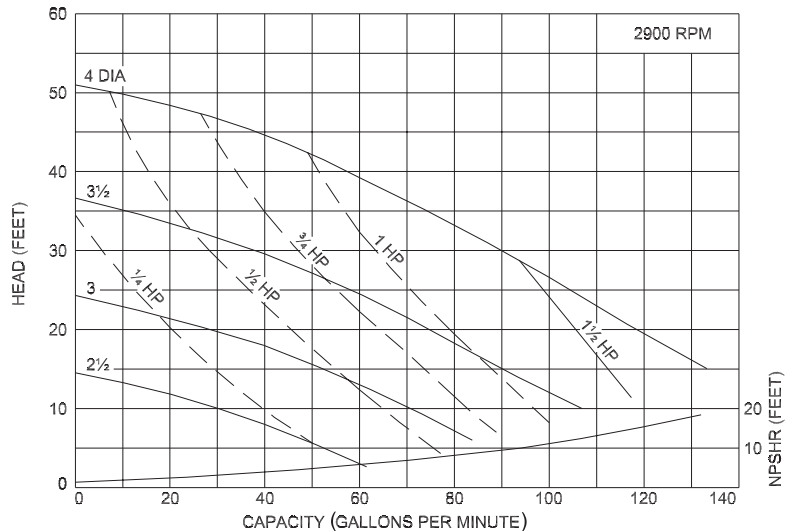

# Ampco Pumps Company

2045 West Mill Road  
Glendale, Wisconsin 53209

PHONE (414) 643-1852

FAX (414) 643-4452