



ROLEC DH Series DH90/ DH250

Operation and Maintenance Manual



Introduction..... 3
 Introduction3
 General Information3
 Shipping Damage or Loss.....3
 Pump Receiving.....3
 Safety.....3

Operation..... 4
 Unit Overview.....4
 Specifications.....4
 DH90/250 Parts Overview.....5
 Suggested Use6
 Unit Configuration6
 Electrical8
 VFD Manual.....8
 DH90/250 Operating.....9

Maintenance..... 14
 Maintenance14
 Spare Parts.....14

Troubleshooting 15

Ampco Pumps Terms and Conditions..... 16

Return Policy..... 19

Introduction

To ensure the best results and service, please read and fully understand this manual prior to putting the unit into service. For any questions regarding operation or maintenance please contact your local distributor or Ampco Pumps Company:

*Ampco Pumps Company
2045 W. Mill Road
Glendale, WI 53209
Phone: (800) 737-8671 or (414) 643-1852
Fax: (414) 643-4452
Email: ampcocs@ampcopumps.com*

General Information

Ampco's ROLEC DH utilizes a SBI shear pump to recirculate a fermenter and simultaneously induce hop pellets into the stream of beer. The hop pellets remain dry until they meet the stream of beer. The DH90 and DH250 utilize a pressurized chamber that is purged of air and constantly filled with CO₂.

Shipping Damage or Loss

Upon receiving equipment that is damaged or if your shipment is lost in transit, immediately file a claim with the carrier. At time of pick-up, the carrier signed the bill of lading, acknowledging that they have received the product from Ampco in good condition.

Pump Receiving

When applicable, Ampco covers the pump inlet and discharge ports prior to shipping, ensuring that foreign matter does not enter the pump during shipment. If the protective covers are missing upon arrival, remove the pump cover and inspect to ensure it is free from contaminate before turning the shafts. Please make note of the serial number; this will assist in the process of ordering replacement parts and/or a warranty claim. For more information regarding shipment damage or warranty, please refer to Terms and Conditions (page 13).

Safety

IMPORTANT: ALWAYS WEAR SAEFTY GLASSES WHEN OPERATING THIS UNIT. Read and understand this manual BEFORE operation or maintenance of the unit. Improper operation or maintenance may result in severe injury or death. Equipment damage caused by user neglect will invalidate the warranty.

There are safety symbols used throughout this manual identifying safety concerns.



WARNING: Hazards or unsafe practices that COULD result in severe personal injury or death, and how to avoid them.

CAUTION: Hazards or unsafe practices that COULD result in minor personal injury or damage to product or property.

Unit Overview

- The SBI shear pump allows recirculation of the fermenter and induction/chopping of pellets and any other ingredients that are induced.
- Once recirculation is established, pellets can be drawn into the tee and then introduced into the stream of beer.
- The pellets are chopped in the SBI shear pump and introduced into the fermenter.
- Recirculation continues as desired after pellets are induced.

Specifications

- The DH90 has a pellet capacity of 90-110 lbs and uses an SBI– R10 shear blender with a 5HP motor. It recirculates up to 2.9 BBLs per minute and has 1.5” x 1.5” ports
- The DH250 has a pellet capacity of 250-300 lbs and uses an SBI-R20 shear blender with a 10HP motor. It recirculates up to 3.7 BBLs per minute, has 2.0” x 2.0” ports
- All models come with a NEMA4X VFD with an integrated on/off breaker.
- All casters are stainless steel.
- The DH90 and DH250 can CIP itself with or without a spray ball because of its internal whirlpool system. The spray ball for the hop chamber is optional.
- All units come standard with a 50’ input power cord.
- All units can be operated at 208V, 230V, or 460V. Voltage must be specified at time of order, VFD will be selected accordingly.

Table 1: Parts Functionality		
Item	Description	Function
A	Motor	Drives the SBI shear pump
B	SBI Shear Pump	Recirculates beer, induces pellets, and chops pellets
C	Sight Glass	User can confirm flooding, flow, and pellet intake
D	Tank Ball Valve	Controls flow of pellets into the stream of beer
E	Pressure Gauge	User can monitor differential pressure to ensure good induction
F	Inlet Butterfly Valve	User can throttle to adjust differential pressure
G	Check Valve	Allows CO ₂ into the hop chamber, but does not allow beer or hops into CO ₂ piping
H	CO ₂ Regulator	Allows user to regulate input CO ₂ into safe operating pressures for hop chamber (<15psi)
I	Ball Valve	Allows flow control of incoming CO ₂ into regulator
J	Pressure Relief Valve	Relieves hop chamber pressure when the pressure exceeds 15 psi
K	Glass Top Manway	Borosilicate lid for hop chamber, allows user to see inside
L	Purge Valve	Allows user to exhaust hop chamber, for example during purging of air
M	Hop Chamber	Holds dose of hop pellets for induction
N	VFD	Electrical control for the motor
O	Whirlpool Valve	Allows some flow into hop chamber from the SBI shear pump

Parts Overview DH90 / DH250

Figure 1

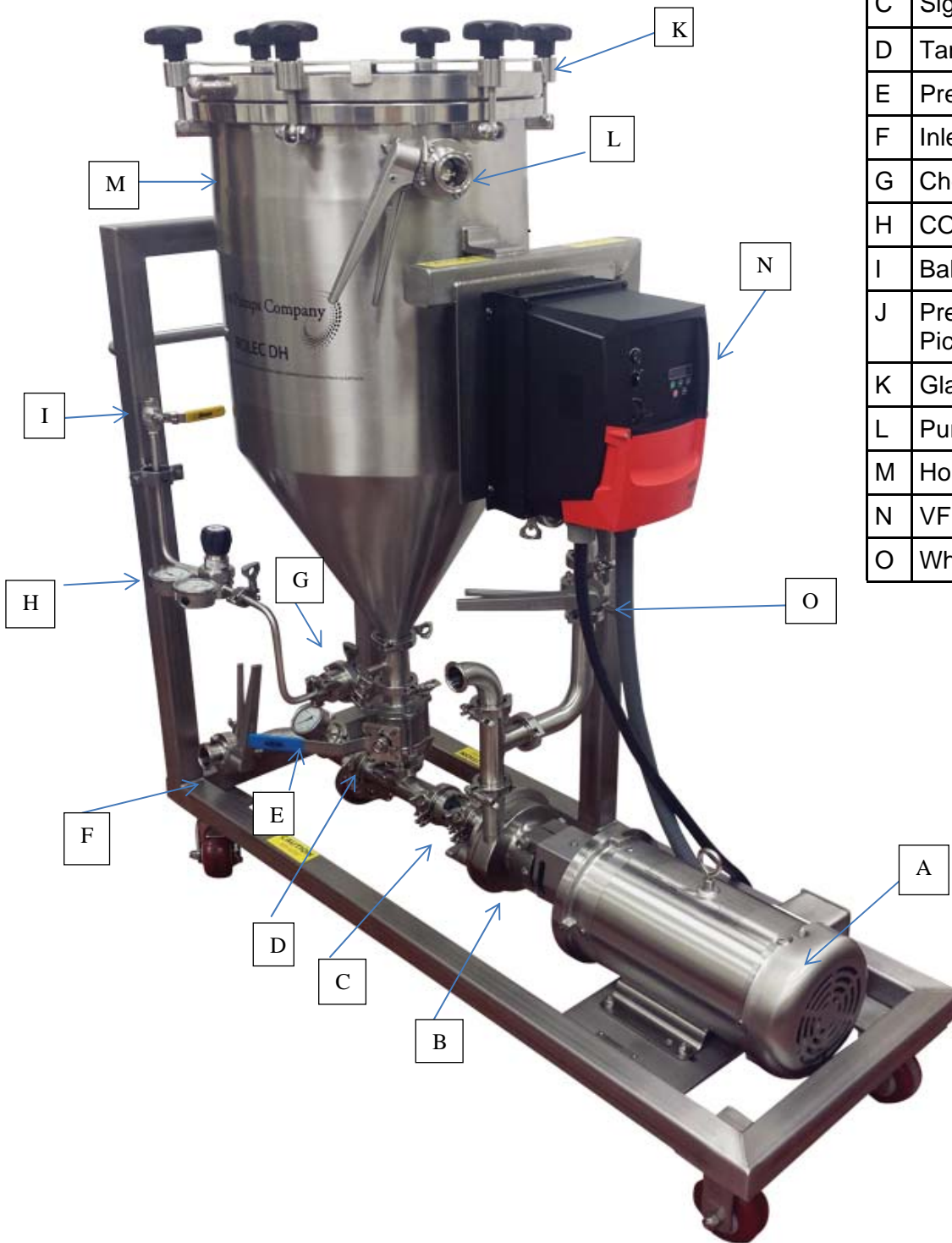

A	Motor
B	SBI Shear Pump
C	Sight Glass
D	Tank Ball Valve
E	Pressure Gauge
F	Inlet Butterfly Valve
G	Check Valve
H	CO ₂ Regulator
I	Ball Valve
J	Pressure Relief Valve (not Pictured)
K	Glass Top Manway
L	Purge Valve
M	Hop Chamber
N	VFD
O	Whirlpool Valve

Suggested Use:

Crashed beer – Induce the pellets and recirculate for three to four full volume turnovers. Sample from the sampling port periodically to get an idea of hop particle exposure.

Un-crashed beer - Induce the pellets and recirculate for three to four full volume turnovers. Sample from the sampling port periodically to get an idea of hop particle exposure.

Fermenting beer - Induce the pellets and STOP. No shearing of the yeast occurs as observed under a microscope, although it is still suggested not to recirculate longer than necessary. Beer may finish early as a result of agitation.

Unit Configuration

The Ampco ROLEC DH Series should be placed as close to the fermenter as possible. Please reference Figures 3-5 for suggested configurations.

*It is highly recommended that a tee with valves on all ends be installed at the end of the discharge hose back to the fermenter. At the perpendicular tee end, add a CO2 connection after the valve. This is utilized later in case of clogs.

Figure 3: Supply From Bottom Port / Discharge Into Racking Arm

This configuration is ideal for breweries that do not have top ports without spray balls. It ensures partial contact, but will rely on recirculation time of the fermenter to ensure full-contact. Three to four full volume turnovers are suggested.

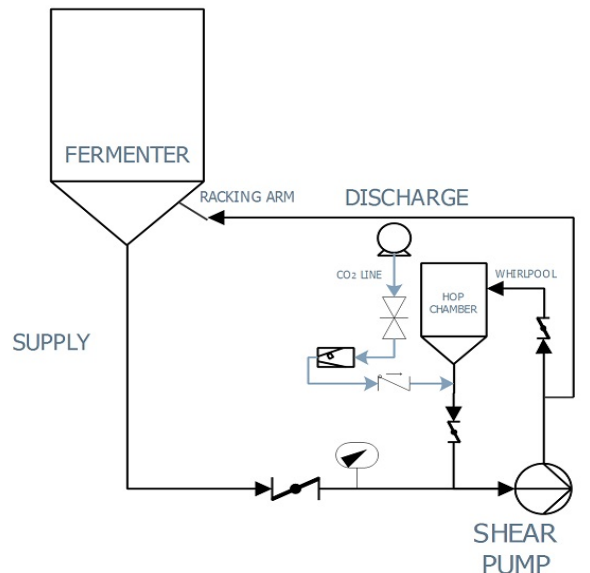

Unit Configuration

Figure 4: Supply From Bottom or Racking Arm / Discharge Into Top Port

This configuration is ideal to ensure maximum exposure. The majority of breweries do not have top ports, so this configuration is not common.

RECOMMENDED SET UP WHEN TOP PORT IS AVAILABLE

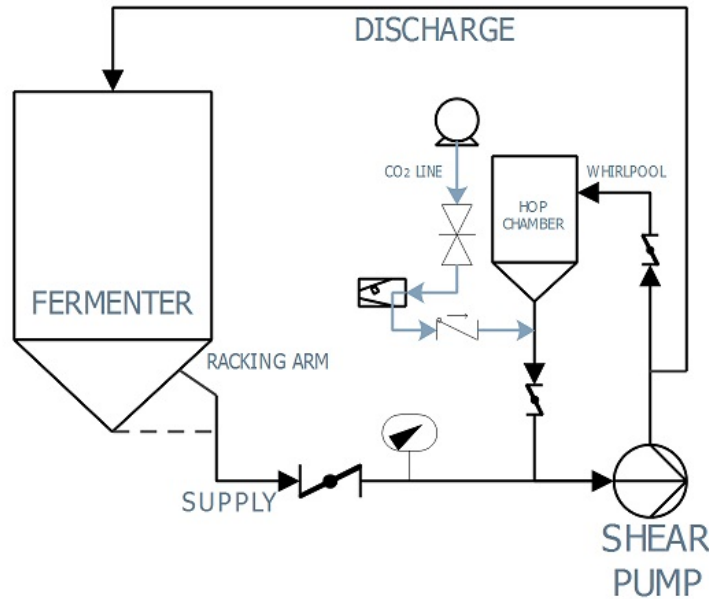
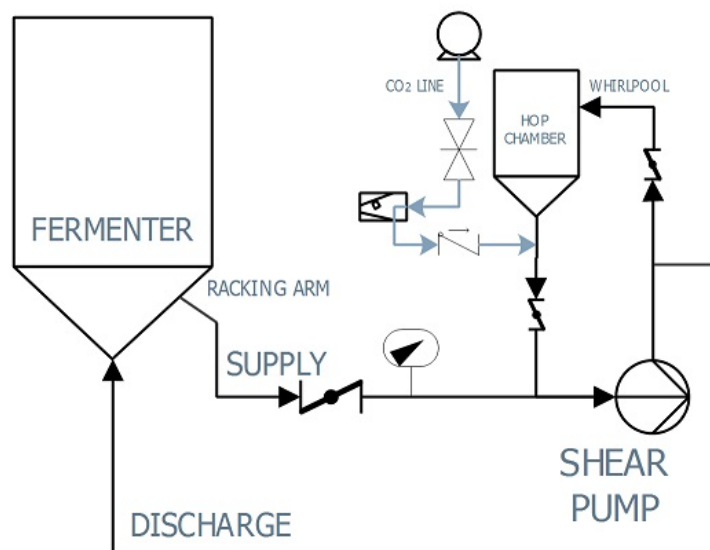

Figure 5: Supply From Racking Arm / Discharge Into Bottom Port

This configuration is necessary for large dry hops where the cone becomes filled with hop sediment. This is normally only a problem on 100+ BBL fermenters. The pump simply cannot pull through the hop sediment once it is too thick. Three to four full volume turnovers are suggest-



Try to use hoses that match the fermenter port size. The longer the hose, the more line loss will occur. This slows the induction and recirculation of the unit.

Electrical

The Ampco ROLEC DH is supplied with an input power cord and plug. The ratings for input are referenced in Table 3.

Table 3: VFD Model Specifications			
VFD Model	HP, Voltage	Max output	Rated input
Movitrac LTEB – MCLTEB0040-2A3-4-40	5 HP, 208-230V	18.0A	20.7A
Movitrac LTEB – MCLTEB0040-5A3-4-40	5 HP, 460V	9.5A	12.4A
Lenze SMVector - ESV752N02TMD	10 HP, 208- 230V	33A	29A
Movitrac LTEB – MCLTEB0075-5A3-4-40	10HP, 460V	24A	20.1A

The VFD parameters must be checked prior to use. The most important parameters are:

- **Full load current of the motor:** The VFD must know the full load current (amps) of the motor it is paired with. This allows the VFD to protect the motor if it is overloaded. *This current is listed on the motor nameplate.*
- **Max frequency:** The suggested setting is 60Hz. This allows the user to ramp up quickly without worrying about overshooting.
- **Acceleration time:** This allows the user to program a time in which the motor will reach the set current.
- **Deceleration mode:** Ampco suggests a “coast” or immediate stop. This is okay when the pump is filled with liquid as the motor will stop quickly from hydraulic drag.
- **Direction:** Ensure the pump is rotating the correct direction. Start at a low frequency and watch the shaft rotation. It should be clockwise when looking at the fan (back of the motor). If it is desired to switch the direction of the motor, but not on the VFD, two of the three motor leads can be switched.

The VFD manual should be carefully read to determine if additional parameters are applicable.

VFD Manuals

<http://download.sew-eurodrive.com/download/pdf/20265743.pdf>

http://download.lenze.com/TD/ESV__SMV%20frequency%20inverter__v18-0__EN.pdf

Operating DH90 / DH250

REFERENCE PAGE 5 FOR LETTER CORRELATION

CIP without sprayball kit:**Step 1: Filling hop chamber with hot water**

For CIPing, the hop chamber (M) should be closed at the glass top manway (K). The whirlpool valve (O), the tank ball valve (D), and purge valve (L) should be opened. Attach a discharge valve (not provided) to the discharge of the unit and close it. Fill the hop chamber (M) with hot water from the hot water supply through the inlet butterfly valve (F). The capacity is 23 gallons for the DH90 and 83 gallons for the DH250. (Can vary by hose length)

Keep the purge valve (L) open until water spills out. When water spills out an acceptable level for CIPing has been reached. Close the hop chamber valve (L).

Step 2: Adding caustic and establishing recirculation loop

Attach a supply hose from the discharge valve (not provided) of the unit looped back to the inlet butterfly valve (F). Open the inlet butterfly valve (F) and the discharge valve (not provided). USING PROTECTIVE EQUIPMENT, add caustic, sanitizing, or passivating solution to the hot water through the glass top manway (K) and re-close it. Turn on the SBI shear pump (B) to 20-35Hz using VFD (N). Allow the pump to recirculate through its piping and whirlpool the hop chamber (M) for 15-60 minutes or as suggested by the operator. Periodically open the purge valve (L) to ensure the seat is cleaned. Periodically cycle the ball valve (D) to ensure proper cleaning.

Step 3: Rinse and sanitize

Drain the hop chamber (M) by easiest method and perform a rinse. Repeat steps 1 and 2 with sanitizer instead of caustic. After the final rinse or sanitizing cycle allow the hop chamber (M) to dry before proceeding.

Ampco Pumps suggests that new equipment be passivated. Repeat step 1 and 2 with acid Solution.



CAUTION/WARNING: Hot water may cause burns. Caustic/Sanitizing solutions may cause chemical burns. Wear proper protective gear when handling hot water and chemicals.

CIP with sprayball kit:

Step 1: Filling hop chamber with hot water

For CIPing, the hop chamber (M) should be closed at the glass top manway (K). The whirlpool valve (O), the tank ball valve (D), and purge valve (L) should be opened. Attach a discharge valve (not provided) to the discharge of the unit and close it. Fill the hop chamber (M) with hot water from the hot water supply through the inlet butterfly valve (F). The capacity is 7 gallons for the DH90 and 23 gallons for the DH250. (Can vary by hose length) This liquid volume will fill the chamber above the conical section. See figure 6.

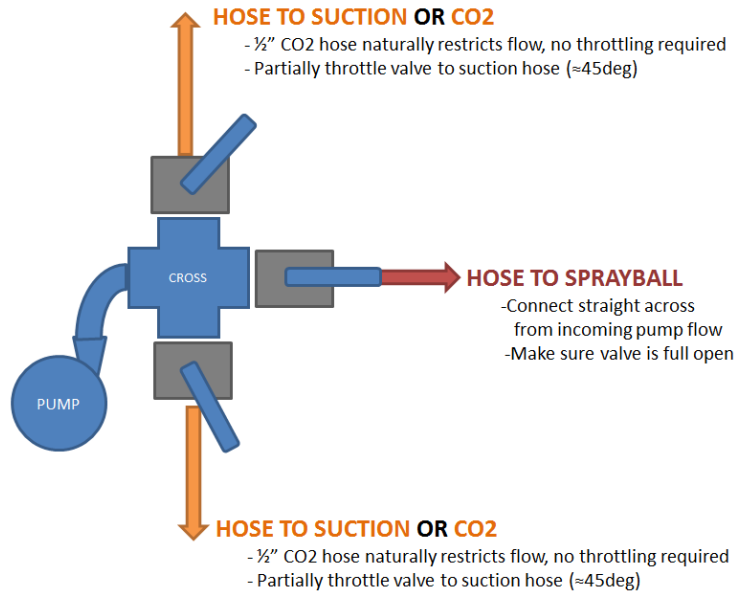

Step 2: Adding caustic and establishing recirculation loop

Attach a supply hose from the discharge valve (not provided) of the unit looped back to the inlet butterfly valve (F), to the sprayball arm and through the check valve with the supplied 1/2" hose. Open the inlet butterfly valve (F) and the discharge valve (not provided). USING PROTECTIVE EQUIPMENT, add caustic or passivating solution to the hot water through the glass top manway (K) and re-close it. Turn on the SBI shear pump (B) using VFD (N) until the sprayball rotates and sprays vigorously. This may require sending more pressure and flow to the sprayball by partially closing the valve to the inlet of the unit (F). Allow the pump to recirculate through its piping and spray the hop chamber (M) for 15-60 minutes or as suggested by the operator. Periodically cycle the ball valve (D) to ensure proper cleaning.

Step 3: Rinse and sanitize

Drain the hop chamber (M) by easiest method and perform a rinse. Repeat steps 1 and 2 with sanitizer instead of caustic. After the final rinse or sanitizing cycle allow the hop chamber (M) to dry before proceeding.

Ampco Pumps suggests that new equipment be passivated. Repeat step 1 and 2 with acid solution.

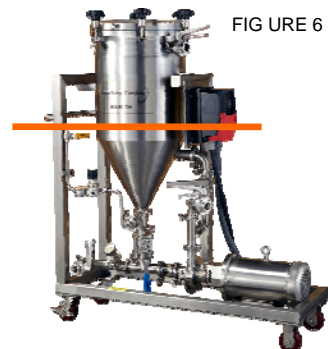

CAUTION/WARNING: Hot water may cause burns. Caustic/Sanitizing solutions may cause chemical burns. Wear proper protective gear when handling hot water and chemicals.

Operating DH90 / DH250

Hop Induction:

Step 1: Bring the fermenter up to pressure – reference figure 7 and the description below

The reason for pressurizing the fermenter is as follows:

1. It will help reduce CO₂ off gassing by way of nucleation.
2. The SBI shear pump (B) should create negative 10psi differential pressure when at 60Hz. If the pressure between the inlet butterfly valve (F) and the SBI shear pump (B) gets near 0 psi, foaming will occur.

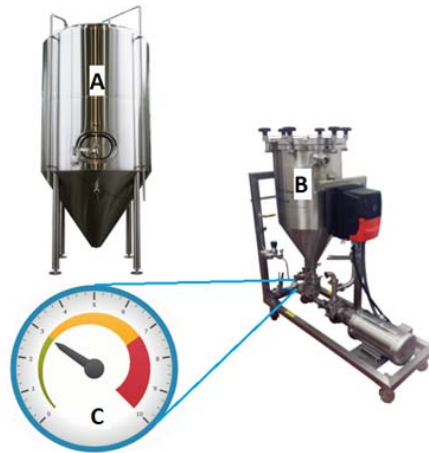

Figure 7

Differential pressure controls the induction rate, and works best when pressure [B] is 3 psi above pressure [C]. Pressure [A] must be controlled via headspace CO₂ pressure to ensure this.

Formulas:

$C = A$ (reference figure 8 below) + fermenter height – 10 psi

$B = C + 3$

NOTE— Careful not to allow pressure at gauge [C] to get too low. Below 3 psi can cause beer to expand/foam, ruining it's head retention.



CAUTION/WARNING: Do not over pressurize hop chamber (M). Doing so can result in serious injury to the operator as well as damage to the unit.

WEAR SAFETY GLASSES, especially when viewing hops through glass top manway (K).

Operating DH90 / DH250



Approximate Fermenter Height	10' (4.3 psi)	15' (6.5 psi)	20' (8.7 psi)	30' (13.0 psi)
Recommended "A" value	6-10 psi	5-9 psi	3-5 psi	2-4 psi

Figure 8

Hook up hoses from the inlet butterfly valve (F) and unit discharge valve (not provided) according to figures 3-5 on pages 7 and 8. Close the whirlpool valve (O) and tank ball valve (D). Flood the pump and check for leaks. Turn on pump and check rotation. Once correct rotation has been confirmed speed pump up to 60hz and record pressure from the pressure gauge (E). Once pressure has been recorded the pump may be reduced to 30-40hz while hops are being added to the hopper and being purged.

Step 2: Purge the hop chamber of air and fill with hops.

Connect the CO₂ source to ball valve (I). Open the ball valve (I). Begin filling the hop chamber (M) with CO₂ while leaving the glass top manway (K) open. Begin filling hop chamber (M) with pellets. Spray the seal on the glass top manway (K) with sanitizer, and then close it. Open the purge valve (L), and allow 3 or 5 minutes of purging to remove air based on unit size 90 and 250 respectively. Close the purge valve (L), and then bring the vessel to beginning pressure based on gauge pressure recorded in previous step at 60hz and formula from figure (7). If the hop chamber (M) exceeds 15 psi, the pressure relief valve (J) will relieve pressure.

Step 3: Establish recirculation

Ensure the inlet butterfly valve (F) is open fully, the tank ball valve (D) is closed, the whirlpool valve (O) is closed, and the discharge valve (not provided) is fully open. Operate the VFD (N), and ensure the motor (A) is turning the correct direction. Increase the motor (A) to 60 Hz.



CUTION/WANING: Do not over pressurize hop chamber (M). Doing s can result in serious injury to the operator as well as damage to the unit.

Operating DH90 / DH250

Step 4: Hop induction

Ensure the gauge pressure at (E) is approximately 3psi lower than tank pressure read at gauge on hopper side of (H). Open the tank ball valve (D), and induction will occur. Fine tune the position of the inlet butterfly valve (F) until induction happens at a steady pace.

During operation:

- A. Ensure the hop chamber (M) can remain near beginning pressure or near 10 psi. Relief through the pressure relief valve (J) may occur.
- B. If a clog occurs, first fully open the inlet butterfly valve (F), and close the ball valve (D) quickly, then re-establish clean flow of beer before attempting to re-open ball valve (D). If needed, repeat item B several times
- C. If clog prevails, close off hop chamber at both valves (D) and (O) then close off butterfly valve to fermenter return. Utilize the tee installed earlier in the setup and the CO₂ connection to attempt to blow the clog out with CO₂ pressure. Clogs can usually be viewed relieving through the site glass on the unit.
- D. If clog still prevails, open the whirlpool valve (O) for a few seconds to whirlpool the vessel.

Caution: Using the whirlpool valve (O) should be a last resort. This valve is designed to break up large clumps of hop pellets. Introducing beer into the hop chamber (M) creates a wet cone, which will promote future sticking. This will make the process more difficult.

Step 5: End of hop induction

Once the pellets have been induced, there will be residual pellets stuck on the side of hop chamber (M). This is when the whirlpool valve (O) should be opened to create a whirlpool and ensure all pellets are induced. Once the pellets are gone, close the whirlpool valve (O), then close the tank ball valve (D). The pressure relief valve (J) may vent to atmosphere during whirlpool. This is acceptable. If more than one fermenter is being dry hopped without a CIP, do not use the whirlpool until the last fermenter is complete.

Ampco recommends a recirculation of 3 to 5 fermenter turnovers. Please reference the DH specifications on pg. 4 to determine the length of time required.



WARNING: Do not over pressurize hop chamber (M). Doing so can result in serious injury to the operator as well as damage to the unit.

WEAR SAFETY GLASSES, especially when viewing hops through glass top manway (K).

Maintenance

The Ampco ROLEC DH should be hot rinsed after use. This is done by performing a rinse cycle; Refill the hop chamber with water and recirculate for a time specified by the user. After the rinse cycle allow the hop chamber to dry completely. This ensures the seal faces are free of particles and product, which can cause damage when used the next time. It also protects the elastomers and seals in the valves and other components from having product adhere to them.

See the [SB/SBH/SBI series shear blenders manual](#) for further maintenance instructions.

See the [Baldor Maintenance Manual](#) for motor lubrication and other information.

IMPORTANT: Ball valve should be disassembled and cleaned out of place regularly regardless of sprayball or COP practices for regular cleaning.

Spare Parts

13MHM100-150	1" - 1-1/2" - SINGLE PIN HEAVY DUTY CLAMP
13MHM200	2" - SINGLE PIN HEAVY DUTY CLAMP
40MPF-U100	1" - CLAMP GASKET BUNA-N (BLACK), FLANGED
40MPF-U150	1-1/2" - CLAMP GASKET BUNA-N (BLACK), FLANGED
40MPF-U200	2" - CLAMP GASKET BUNA-N (BLACK), FLANGED
40MPF-U50	1/2"-CLAMP GASKET BUNA-N (BLACK), FLANGED
B5101E150CC-C	1.5" BUTTERFLY VALVE WITH TRICLAMP INOX
B5101E200CC-C	2" BUTTERFLY VALVE WITH TRICLAMP INOX
RDH09010030	PRESS RELIEF VALVE W/CLAMP, DH090, 1", EPDM, 5-75PSI
RDH09010050	CHECK VALVE, DH090, 1/2"CLMP, 316L-SS
RDH09010060	PRESSURE GAUGE, DH090,3 1/2" SS, 0-30PSI
S1100-200-EP	SANITARY SIGHT FLOW - 2" CLAMP CONNECTION

Troubleshooting

Problems may occur over the life of the unit due to system variations, standard wear, or user error. The following table has information that may help identify and solve a problem. For additional technical assistance, please contact Ampco with the pump's serial number.

Symptom	Cause	Solution
Pump will not flood when fermenter's beer is introduced	Air-lock	Ensure the inlet butterfly valve is open
	Too much cone sediment in fermenter	Switch hoses (Figure 4/5 page 7)
No flow	Direction of pump is incorrect	Switch direction in VFD (page 8)
	Too much cone sediment in fermenter	Switch hoses (Figure 4/5 page 7)
	Speed of pump too low	Increase speed on the VFD
	Discharge valve closed/ not open enough	Open discharge valve
	The inlet butterfly valve is throttled too far	Open the inlet butterfly valve slightly
Hops will not flow down hop chamber funnel	Not enough differential pressure	Throttle the inlet butterfly valve more (more closed)
	Pellet clump/clog	Quickly open the inlet butterfly valve then re-throttle to its original position
	Pellet clump/clog persists	Open the whirlpool valve to break up clumps. This should be a last resort
VFD stops and displays error	High amps detected	Check current setting in parameters (page 8). If parameters are correct, run pump slower or at a higher backpressure on discharge
	Other	Reference VFD manual (page 8)
Pressure Relief Valve is venting to atmosphere	Pressure in vessel has exceeded 15 psi	Adjust CO ₂ regulator to lower pressure in vessel
		The whirlpool valve is open allowing pump discharge to pressurize hop chamber. This is normal.

AMPCO PUMPS

Made of SELECTED corrosion-resistant alloys

TERMS AND CONDITIONS OF SALE

1. ENTIRE AGREEMENT. This document contains all of the terms and conditions of the agreement (“the agreement”) between Ampco Pumps Company, Inc. (“Seller”) and the purchaser (“Purchaser”) of the Products (“Products”) to be sold to Purchaser, to the exclusion of any other statements and agreements, and to the exclusion of any terms and conditions incorporated in Purchaser’s order or other documents of Purchaser. Seller’s acceptance of Purchaser’s order is expressly conditioned on Purchaser’s acceptance of the terms and conditions contained herein, and Purchaser, upon placing an order, is presumed to have accepted all the terms and conditions without modification. No alteration, waiver, modification of or addition to the terms and conditions herein shall be binding on Seller unless set forth in writing and specifically agreed to by an officer of Seller. No course of dealing, usage of trade or course of performance will be relevant to supplement or explain any terms used in the agreement. All offers to purchase, quotations and contracts of sale are subject to final acceptance by Seller at its home office at Milwaukee, Wisconsin.

2. PRICES. Prices for Products manufactured by Seller pursuant to written accepted orders will remain firm for thirty (30) days from the date of any subsequent price change.

3. TERMS OF PAYMENT. Standard terms are ½% 10 days, 30 days net, from date of invoice unless otherwise stated. If, in the judgment of Seller, the financial condition of Purchaser at any time does not justify continuance of production or shipment on the terms of payment specified, Seller may require full or partial payment in advance. In cases of delays in payment, Seller reserves the right to charge interest on delinquent balances at the rate of 1 ½% per month.

4. DELIVERY. Except as otherwise provided expressly stated in the agreement, Products are sold F.O.B. Milwaukee. Seller will use reasonable commercial efforts to fill orders within the time stated, but the stated delivery date is approximate only, and Seller reserves the right to readjust shipment schedules without liability. Acceptance by Purchaser of the Products waives any claim for loss or damage resulting from a delay, regardless of the cause of the delay. Except as otherwise provided herein, Seller will not be responsible for freight, transportation, insurance, shipping, storage, handling, demurrage or similar charges. Claims by Purchaser for shortages in the Products must be made to Seller in writing within ten (10) days after date of receipt of the Products. No such shortage shall entitle Purchaser to withhold payment for Products which were received by Purchaser. Each such claim shall set forth in detail the basis and amount of such claim.

5. TAXES AND FEES. Seller shall pay all present and future sales, excise, privilege, use or other taxes, customs duties, and all other fees or other costs, imposed by any federal, state, foreign, or local authorities arising from the sale, purchase, transportation, delivery, storage, use or consumption of the Products or will, if applicable, provide Seller with an appropriate exemption certificate. Seller shall be under no obligation to contest the validity of any such taxes or to prosecute any claims for refunds or returns.

6. INSTALLATION. The Products shall be installed by and at the expense of Purchaser.

7. LOSS, DAMAGE OR DELAY. Seller will not be liable for loss, damage or delay resulting from causes beyond its reasonable control, including, without limitation, strikes or labor difficulties, lockouts, acts or omissions of any governmental authority or Seller, insurrection or riot, war, fires, floods, Acts of God, breakdown of essential machinery, accidents, embargoes, cargo or material shortages, delays in transportation, lack of production capacity or inability to obtain labor, materials or parts from usual sources. In the event of any such delay, performance will be postponed by such length of time as may be reasonably necessary to compensate for the delay. In the event performance by Seller under the agreement cannot be accomplished by Seller due to any of the foregoing causes within a reasonable period of time, Seller may, at its option, terminate the agreement without liability.

8. RETURNS. No Products or parts may be returned by Purchaser without the prior written consent of Seller.

9. WARRANTY. Seller warrants that the Products manufactured by Seller will be free from defects, material and workmanship under normal use and service for a period of one (1) year from date of shipment. In addition, the specified rating of each pump is warranted; however, the characteristic shape of the performance curves may vary from the published standards, and the capacity, head and efficiency guarantees are based on actual shop tests using clear cold water, and therefore the rating is specified in equivalent units of clear cold water. The sole obligation of Seller and the exclusive remedy of Purchaser for breach of this warranty shall be the repair (at Seller’s facility) or replacement by Seller (F.O.B. Milwaukee, Wisconsin), at Seller’s option, of any parts found to be defective, without charge and shall be conditioned upon Seller receiving written notice of any alleged breach of this warranty within a reasonable time after discovery of the defects, but in no event later than the end of the warranty period. The parts alleged to be defective shall be returned to Seller upon its request, freight prepaid. This warranty does not cover ordinary wear and tear, abuse, misuse, overloading, alteration or Products or parts which have not been installed, operated or maintained in accordance with Seller’s written instructions. Seller shall not be liable for any expenses for repairs, additions or modifications to the Products outside of Seller’s factory without its prior written consent, and any such repairs without such consent shall void this warranty. THIS WARRANTY IS EXCLUSIVE AND IS IN LIEU OF ALL OTHER EXPRESS AND IMPLIED WARRANTIES WHATSOEVER, INCLUDING BUT NOT LIMITED TO IMPLIED WARRANTIES OF MERCHANTABILITY AND FITNESS FOR A PARTICULAR PURPOSE. Seller may from time to time provide its facilities, personnel and experience to assist customers in the selection of materials, design, installation and operation of Products for maximum resistance to corrosion and abrasion with due consideration to the economy of the installation. This service is provided in an advisory capacity only and the final selection and operation of the Products and ancillary equipment shall be the sole responsibility of Purchaser or any user thereof. Accessories and parts manufactured by third parties are warranted only to the extent of such third party’s warranty. IN NO EVENT SHALL SELLER BE LIABLE UNDER ANY CIRCUMSTANCES FOR ANY INCIDENTAL, CONSEQUENTIAL OR SPECIAL DAMAGES (INCLUDING, WITHOUT LIMITATION, ANY LOST PROFITS OR LABOR COSTS) ARISING FROM THE BREACH OF THIS WARRANTY OR OTHERWISE ARISING FROM OR RELATING TO THE PRODUCTS OR THEIR SALE, USE OR INSTALLATION.

Terms and Conditions

Ampco Pumps Company

10. CHANGES. Changes in any work to be performed hereunder may be made only upon Purchaser's written instructions and acceptance by Seller in its discretion. Any change in drawings, materials or design of the Products, or to tools, fixtures or other items used to produce the Products, which affects Seller's cost to produce the Products will entitle Seller to adjust the price to take into account any additional costs. If work has been started, Seller shall be properly reimbursed for work already performed; if Products already produced are not accepted by Purchaser, Seller has the right to adjust the price to take into account any additional costs caused by an increase or decrease in quantities or in the time required for performance under the agreement.

11. TERMINATION. After Seller has commenced work, ordered any materials or made any other commitments pursuant to the agreement, it may be terminated only with the prior written agreement of Seller providing for equitable cancellation charges. Such charges shall reimburse Seller for any completed items at the contract price, and for any work-in-process items at the contract price less the cost to complete. Termination on any other basis must be specifically agreed on in writing in advance between Purchaser and Seller.

12. DEFERRED DELIVERIES. Orders or deliveries will be deferred only upon the prior written agreement of Seller in its discretion, and then only upon the following conditions:

(a) The deferral period may not exceed sixty (60) days. At the end of the deferral period, if no release is provided by Purchaser, Seller reserves the right to render an invoice for and ship the completed portion of the order to the destination specified in Purchaser's order, or to store such material at Purchaser's expense at Seller's standard storage charges then in effect.

(b) For the portion of the order that is not completed, if no release is provided by Purchaser at the expiration of the deferral period, Seller reserves the right to render an invoice for any completed items at the contract price, and for any work-in-process items at the contract price less the cost to complete.

(c) Purchaser shall bear the risk of loss or damage to materials held at Purchaser's request.

13. LIMITATION OF LIABILITY. IN NO EVENT SHALL SELLER BE LIABLE UNDER ANY CIRCUMSTANCES: (a) FOR ANY INCIDENTAL, CONSEQUENTIAL OR SPECIAL DAMAGES (INCLUDING, WITHOUT LIMITATION, ANY LOST PROFITS OR LABOR COSTS) ARISING FROM OR RELATING TO THE PRODUCTS OR THEIR SALE, USE OR INSTALLATION; (b) FOR DAMAGES TO PROPERTY (OTHER THAN THE PRODUCTS PURCHASED FROM SELLER); (c) FROM ANY BREACH OF ITS WARRANTY OR ANY OTHER OBLIGATIONS TO BUYER; OR (d) FOR ANY OTHER CAUSE WHATSOEVER, WHETHER BASED ON WARRANTY (EXPRESSED OR IMPLIED) OR OTHERWISE BASED ON CONTRACT, OR ON TORT OR OTHER THEORY OF LIABILITY, AND REGARDLESS OF ANY ADVICE OR REPRESENTATIONS (WHETHER OR NOT IN WRITING) THAT MAY HAVE BEEN RENDERED BY SELLER CONCERNING THE DESIGN, MANUFACTURE, SALE, USE OR INSTALLATION OF THE PRODUCTS.

14. INFRINGEMENT. Seller at its expense will defend and hold Purchaser harmless from and against all damages, costs and expenses arising from any valid claim of infringement by a third party with respect to any patent or other intellectual property rights (collectively, the "Intellectual Property Rights") caused by Products originally manufactured by Seller, provided Purchaser (a) has not modified such Products, (b) gives Seller immediate notice in writing of any claim or commencement or threat of suit, and (c) permits Seller to defend or settle the same, and gives all immediate information, assistance and authority to enable Seller to do so. In the event any such originally manufactured Products are held to infringe an Intellectual Property Right and if Purchaser's use thereof is enjoined, Seller will, at its expense and option: (1) obtain for Purchaser the right to continue using the Products, (2) supply non-infringing Products, (3) modify the Products so that they become non-infringing, or (4) refund the then market value of such Products. In no event shall Seller's liability exceed the sale price of the infringing Products. THE FOREGOING REPRESENTS SELLER'S ENTIRE AND EXCLUSIVE OBLIGATION WITH RESPECT TO ANY CHARGE OF INFRINGEMENT OF ANY INTELLECTUAL PROPERTY RIGHT AND IS IN LIEU OF ANY STATUTORY WARRANTY RELATING TO INFRINGEMENT. Notwithstanding the foregoing, Seller shall have no liability as to any Products or parts thereof that are manufactured or modified by Purchaser or a third party, or that are manufactured or modified by Seller in accordance with Purchaser's specifications. Purchaser will defend and hold Seller harmless from and against all damages, costs and expenses whatsoever arising from any claim for infringement of any Intellectual Property Rights relating to Products that have been manufactured or modified by Seller according to specifications provided by Purchaser.

15. CERTAIN LAWS. Seller will comply with the applicable requirements of the Fair Labor Standards Act of 1938, as amended, Executive Order 11246, and THE rules, regulations and orders of the Secretary of Labor relating thereto.

16. PERIOD FOR ACCEPTING QUOTATIONS. Unless accepted without modification within thirty (30) days of issuance, or prior to withdrawal by Seller if earlier, all quotations automatically expire at the end of such thirty (30) day period.

Terms and Conditions

Ampco Pumps Company

17. PROVISIONS FOR INTERNATIONAL TRANSACTIONS. The following provisions shall apply if the Products are to be shipped to Purchaser at a location outside the United States, and apply regardless of other provisions set forth in these Terms and Conditions:

(a) The 1980 United Nations Convention on Contracts for the International Sale of Products shall not apply.

(b) Except as otherwise provided expressly stated in the agreement, terms of delivery are Ex-Works (within the meaning of INCOTERMS 2000) and all customs fees, import duties, cargo insurance, taxes and other charges imposed on or relating to the purchase or sale of the Products shall be paid by Purchaser in addition to the stated price.

(c) Except as otherwise provided expressly stated elsewhere in the agreement, payment shall be made by issuance to Seller of an irrevocable letter of credit which (i) is issued and confirmed by a U.S. bank acceptable to Seller, (ii) is governed by the Uniform Customs and Practice for Documentary Credits (UCP 600) and otherwise acceptable in form and substance to Seller, and (iii) provides for payment to Seller of the purchase price in U.S. dollars upon presentation by Seller of Seller's certification and/or such other documents as shall be required by the letter of credit. All banking and other charges for such letter of credit shall be for the account of Purchaser.

(d) Prices include Seller's standard commercial export packaging which may vary depending on whether shipment is made by air, land or sea. Except as otherwise provided expressly stated in the agreement, Purchaser will bear any additional expenses required to satisfy Purchaser's packaging requirements. Packages will be marked in accordance with Purchaser's instructions, if any. Seller shall furnish packing lists and such other information as may be necessary to enable Purchaser's agent to prepare documents required for export shipment.

(e) All shipments hereunder are subject to compliance with the U.S. Export Administration Act, as amended, regulations thereunder and all other U.S. laws and regulations concerning exports. Purchaser shall comply with all such laws and regulations concerning the use, disposition, re-export and sale of the Products provided hereunder.

18. GENERAL. No modification or waiver of the agreement or any of its provisions is valid unless expressly agreed to by Seller in writing, and no waiver by Seller of any default under the agreement is a waiver of any other or subsequent default. The unenforceability or invalidity of one or more of the provisions of the agreement will not affect the enforceability or validity of any other provision of the agreement. Purchaser may not assign any of its rights, duties or obligations under the agreement without Seller's prior written consent and any attempted assignment without such consent, even if by operation of law, will be void. The agreement is governed by and shall be construed in accordance with the laws of the State of Wisconsin, including the Uniform Commercial Code as enacted by such state, without giving effect to its conflict of laws principles.

Return Policy

Ampco Pumps Company

This policy is intended for returns that are not covered by product warranty, i.e. wrong pump or part was ordered, customer canceled order, etc. Before returning any product, contact us for a Returned Material Authorization Number (RMA#). This will eliminate confusion when the parts are received and facilitate processing the return. No action will be taken on returned parts without an RMA.

<u>Type of Return</u>	<u>Restocking Charge</u>
Standard pump with a replacement order	10%
Standard pump without a replacement order	20%
Standard parts with a replacement order	5%
Standard parts without a replacement order	10%

Additional restocking charges may be assessed for any of the following circumstances.

1. Special order motors and seals are not returnable unless we have a use for them. Credit will be determined on a case-by-case basis.
2. Impellers that are trimmed to a diameter that we don't regularly use are not returnable. Credit will be determined on a case-by-case basis.
3. Used seals and motors are not returnable.
4. For any pumps and/or parts purchased over (1) year ago, credit will be determined on a case-by-case basis.

Credits

Credit will be issued only after parts are returned and inspected. Customer is responsible for packaging parts so they are returned in "as new" condition. Any labor required by Ampco to return the parts to "as new" condition will be deducted from the credit.



Ampco Pumps Company
2045 W. Mill Road
Glendale, WI 53209
Phone: (800) 737-8671 or (414) 643-1852
Fax: (414) 643-4452
Email: ampco@ampcopumps.com

For additional information on the ROLEC DH series and other Ampco Pumps products, please visit our website: **www.ampcopumps.com**