

Ampco Centrifugal Pumps

DATA SHEET

MODEL ZF 4X3

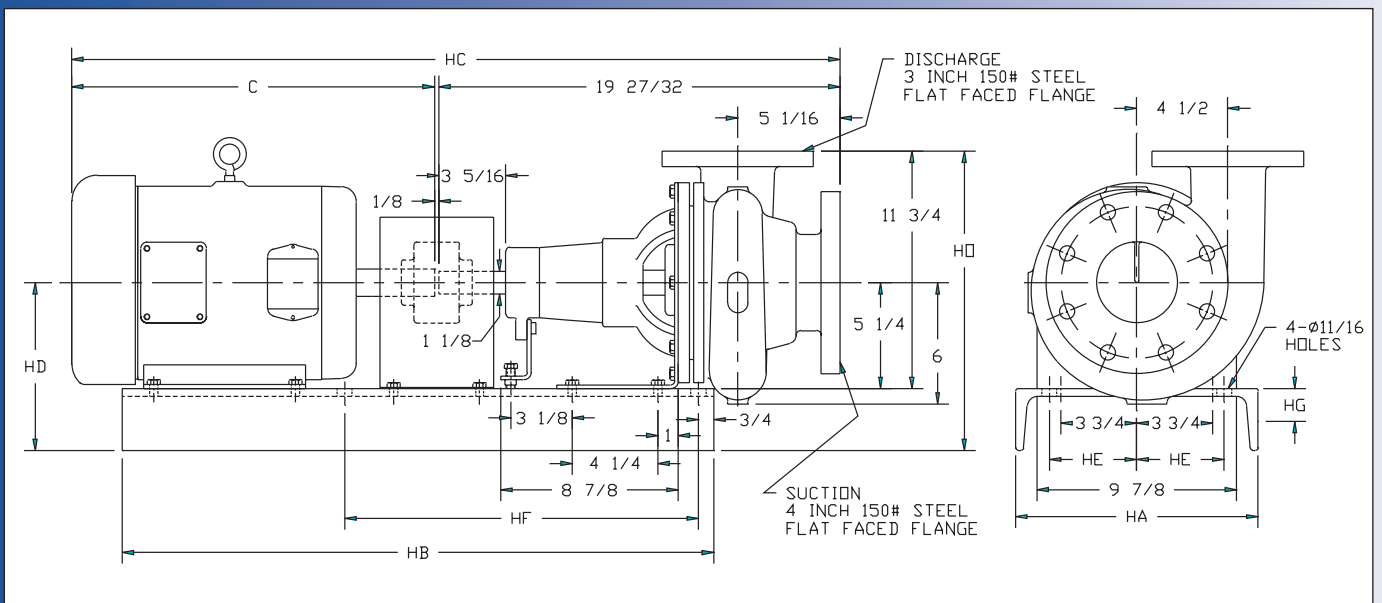
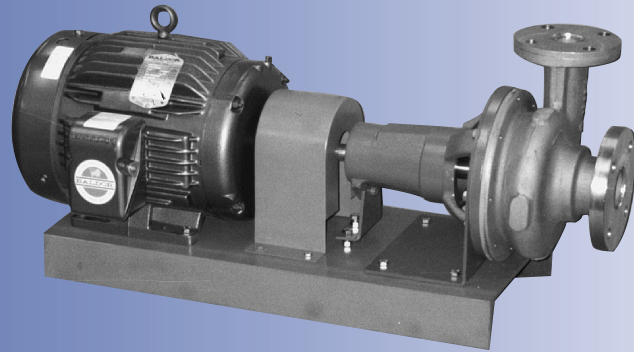

TEFC MOTOR			DIMENSIONS IN INCHES (For Reference Only)								
HP	RPM	FRAME	C	HA	HB	HC	HD	HE	HF	HG	HO
2	1750	145T	13-1/16	10	25-3/4	32-3/8	7-7/8	2-3/4	14-1/4	2-5/8	14-5/8
3	1700	182T	15-3/8	10	25-3/4	34-11/16	7-7/8	3-3/4	16-1/4	2-5/8	14-5/8
5	3500	184T	15-3/8	10	25-3/4	34-11/16	7-7/8	3-3/4	16-1/4	2-5/8	14-5/8
7-1/2	3500	213T	19-7/16	12	27-3/4	38-3/4	8-1/4	4-1/2	17-1/2	3	15
10	3500	215T	19-7/16	12	27-3/4	38-3/4	8-1/4	4-1/2	17-1/2	3	15
15	3500	254T	24-9/16	15	33-3/4	43-7/8	9-5/8	6	18	3-3/8	16-3/8

MATERIAL SPECIFICATIONS

PART NAME	NICKEL ALUMINUM BRONZE	STAINLESS STEEL
Casing, Cover & Impeller	AMPCO® 483	316 Stainless
Wear Ring	AMPCO® 18	316 Stainless
Shaft	Steel	Steel
Shaft Sleeve	AMPCO® 18	316 Stainless
Frame	Cast Iron	Cast Iron

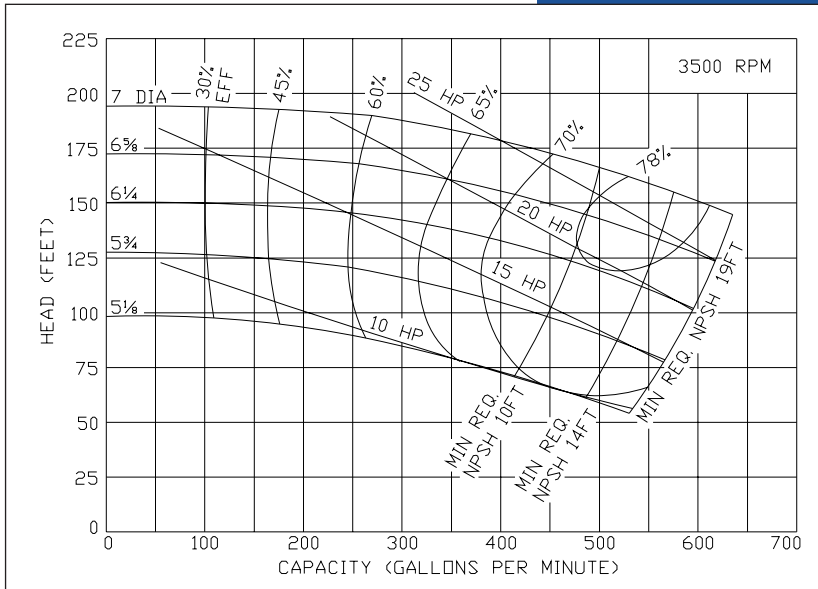

Ampco Centrifugal Pumps

MODEL ZF 4X3

Curves show approximate characteristics based on clear 68° water. Rated point is guaranteed.

Heavy-duty Z Series pumps have maximum wall thickness and 150 lb. flat faced flanged connections. Seal options include Type 21, Type 1 and Type 9 with choice of sealing materials.

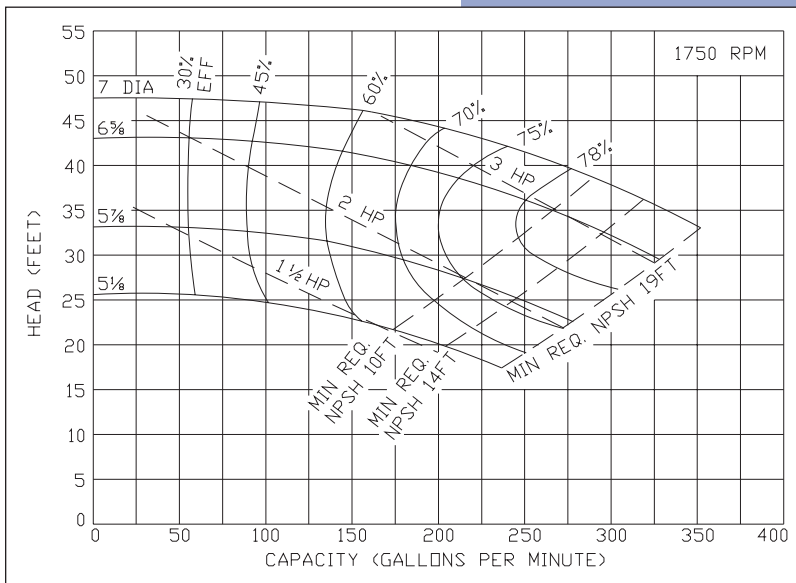
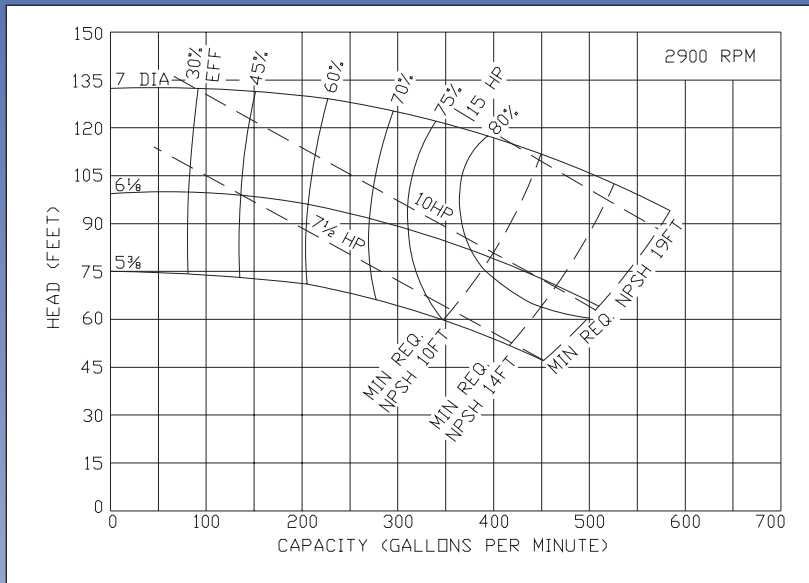

Ampco Pumps Company

4424 West Mitchell Street
 Milwaukee, Wisconsin 53214
 PHONE (414) 643-1852
 FAX (414) 643-4452