

Ampco Centrifugal Pumps

DATA SHEET

MODEL ZCH2 6X6

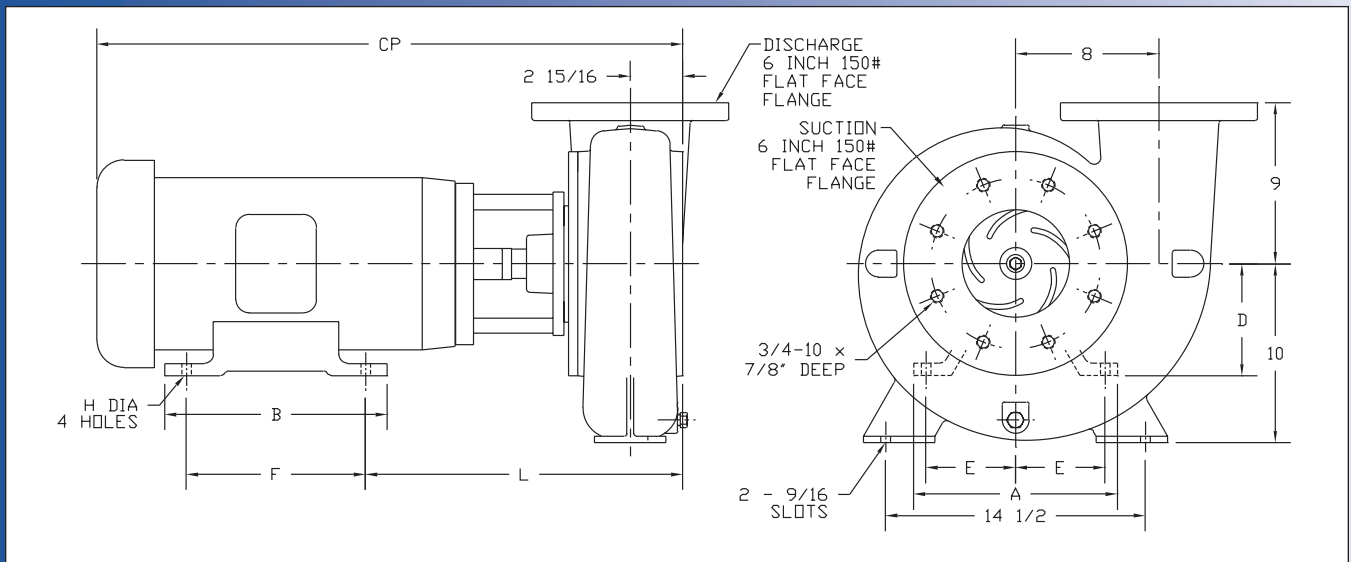
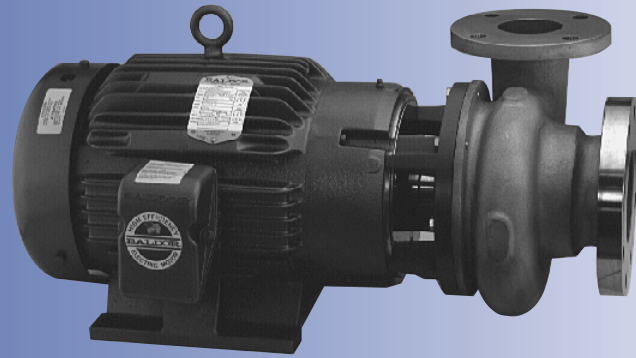

TEFC MOTOR			DIMENSIONS IN INCHES (For Reference Only)								APPROX. WEIGHT (LBS)
HP	RPM	FRAME	A (typ)	B (typ)	D	E	F	H	L	CP	
10	1750	215JP	9-1/2	8	5-1/4	4-1/4	7	13/32	17	28-1/16	439
15	1750	254JP	11-1/2	9-3/4	6-1/4	5	8-1/4	17/32	17-1/4	30-5/16	537
20	1750	256JP	11-1/2	11-1/2	6-1/4	5	10	17/32	17-1/4	32-3/16	570
25	1750	284JP	12-3/4	12-3/4	7	5-1/2	9-1/2	17/32	17-1/4	35-11/16	764
30	1750	286JP	12-3/4	12-3/4	7	5-1/2	11	17/32	17-1/4	36-5/16	774

MATERIAL SPECIFICATIONS

PART NAME	NICKEL ALUMINUM BRONZE	STAINLESS STEEL
Casing, Cover & Impeller	AMPCO® 483	316 Stainless
Wear Ring	AMPCO® 18	316 Stainless
Motor Shaft	Steel	Steel
Shaft Sleeve	AMPCO® 18	316 Stainless
Adapter	Cast Iron	Cast Iron

Ampco Centrifugal Pumps

MODEL ZCH2 6X6

Curves show approximate characteristics based on clear 68° water. Rated point is guaranteed.

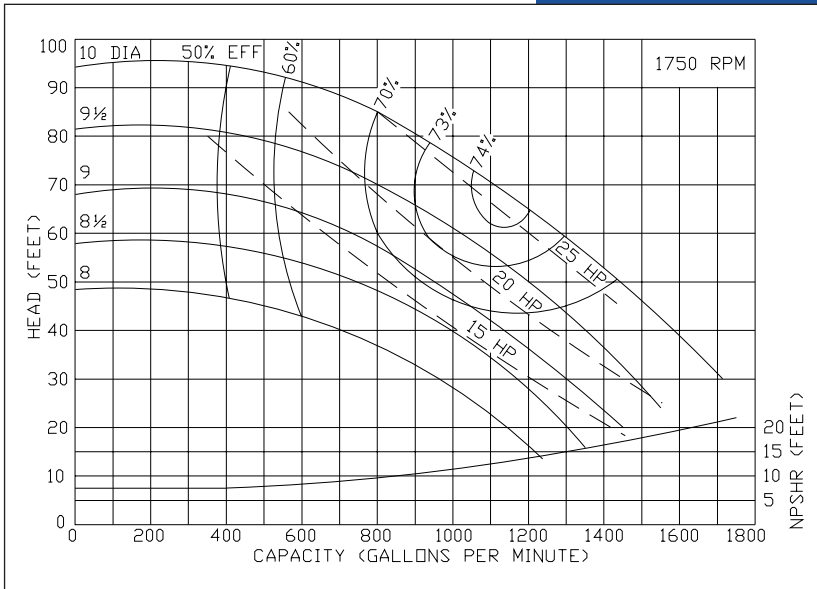

Heavy-duty Z Series pumps have maximum wall thickness and 150 lb. flat faced flanged connections.

Seal options include Type 21, Type 1 and Type 9 with choice of sealing materials.

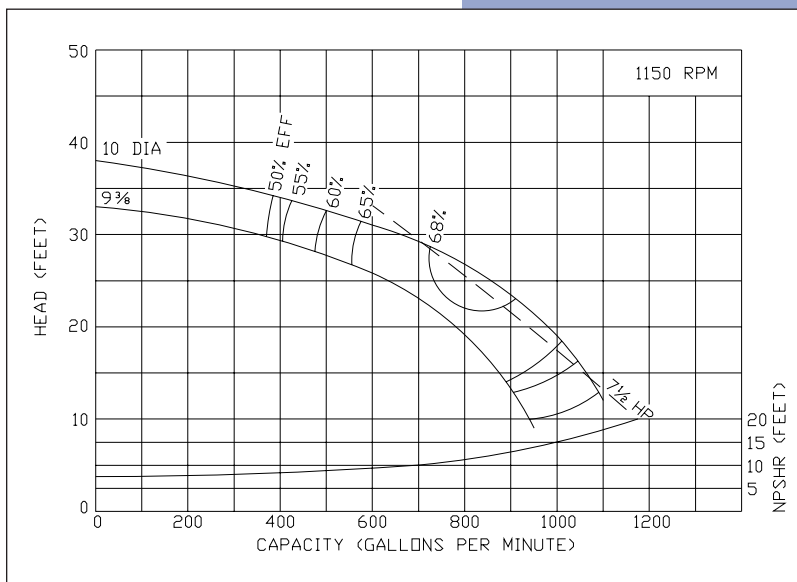
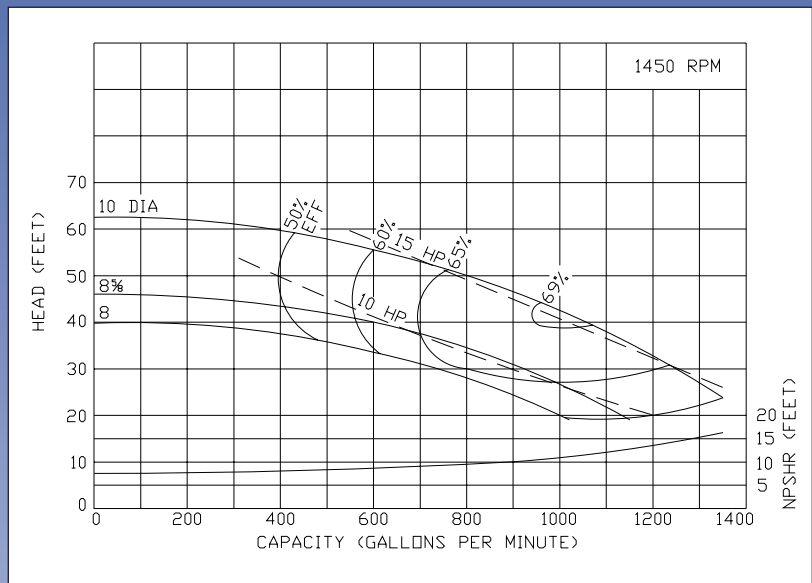

Ampco Pumps Company

4424 West Mitchell Street
 Milwaukee, Wisconsin 53214
 PHONE (414) 643-1852
 FAX (414) 643-4452