

Ampco Centrifugal Pumps

DATA SHEET

MODEL ZC2/ZCH2 4X3

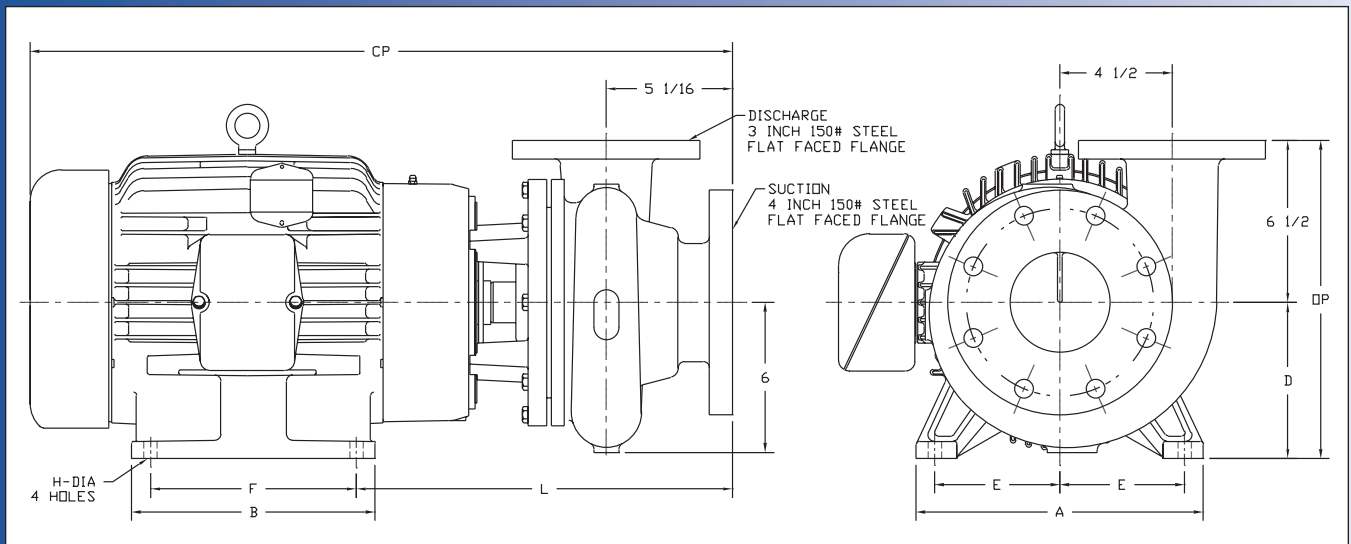

	TEFC MOTOR			DIMENSIONS IN INCHES (For Reference Only)									APPROX. WEIGHT (LBS)
	HP	RPM	FRAME	A (max)	B (max)	D	E	F	H	L	CP	OP	
ZC2	1-1/2	1750	145JM	6-1/2	6	3-1/2	2-3/4	5	11/32	12-3/16	20-1/2	10	152
ZC2	2	1750	145JM	6-1/2	6	3-1/2	2-3/4	5	11/32	12-3/16	20-1/2	10	158
ZC2	3	1750	182JM	8-5/8	6-1/2	4-1/2	3-3/4	4-1/2	13/32	12-13/16	21-7/8	11	184
ZC2	5	1750	184JM	8-5/8	6-1/2	4-1/2	3-3/4	5-1/2	13/32	12-13/16	23-7/16	11	197
ZC2	10	3500	215JM	9-5/8	8-1/8	5-1/4	4-1/4	7	13/32	13-9/16	26-1/8	11-3/4	283
ZCH2	15	3500	254JM	11-1/2	9-3/4	6-1/4	5	8-1/4	17/32	15-1/16	28-1/8	12-3/4	391
ZCH2	20	3500	256JM	11-1/2	11-1/2	6-1/4	5	10	17/32	15-1/16	29-15/16	12-3/4	429
ZCH2	25	3500	284JM	12-3/4	12-3/4	7	5-1/2	9-1/2	9/16	15-1/16	33-1/2	13-1/2	559
ZCH2	30	3500	286JM	12-3/4	12-3/4	7	5-1/2	11	9/16	15-1/16	34-1/8	13-1/2	688

MATERIAL SPECIFICATIONS

PART NAME	NICKEL ALUMINUM BRONZE	STAINLESS STEEL
Casing, Cover & Impeller	AMPCO® 483	316 Stainless
Wear Ring	AMPCO® 18	316 Stainless
Motor Shaft	Steel	Steel
Shaft Sleeve	AMPCO® 18	316 Stainless
Adapter	Cast Iron	Cast Iron

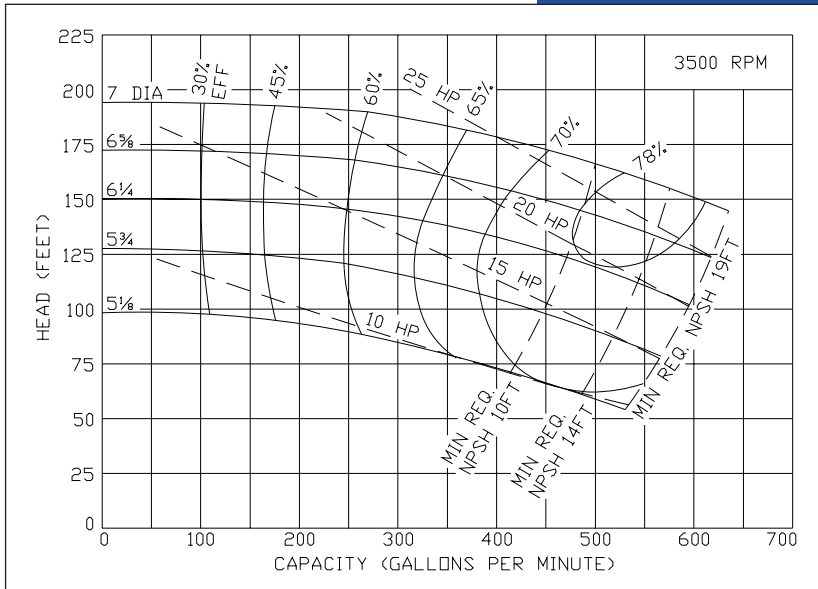

Ampco Centrifugal Pumps

MODEL ZC2/ZCH2 4X3

Curves show approximate characteristics based on clear 68° water. Rated point is guaranteed.

Heavy-duty Z Series pumps have maximum wall thickness and 150 lb. flat faced flanged connections.

Seal options include Type 21, Type 1 and Type 9 with choice of sealing materials.

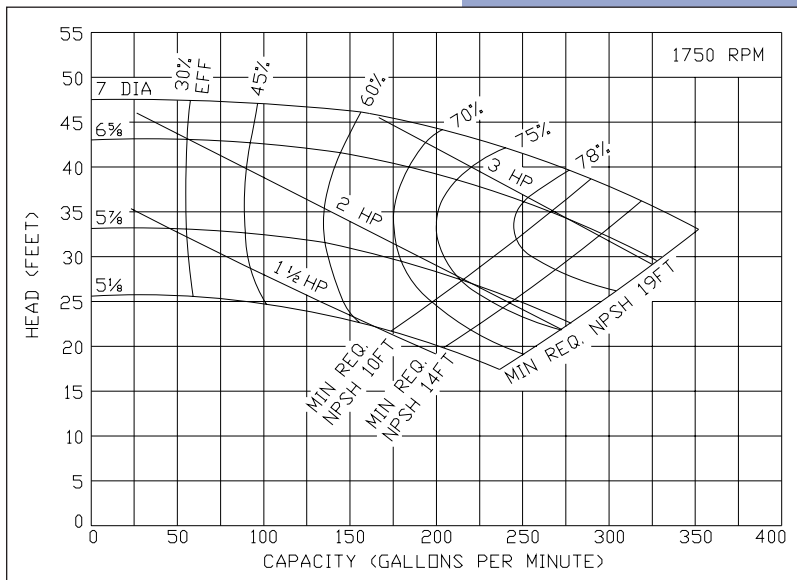
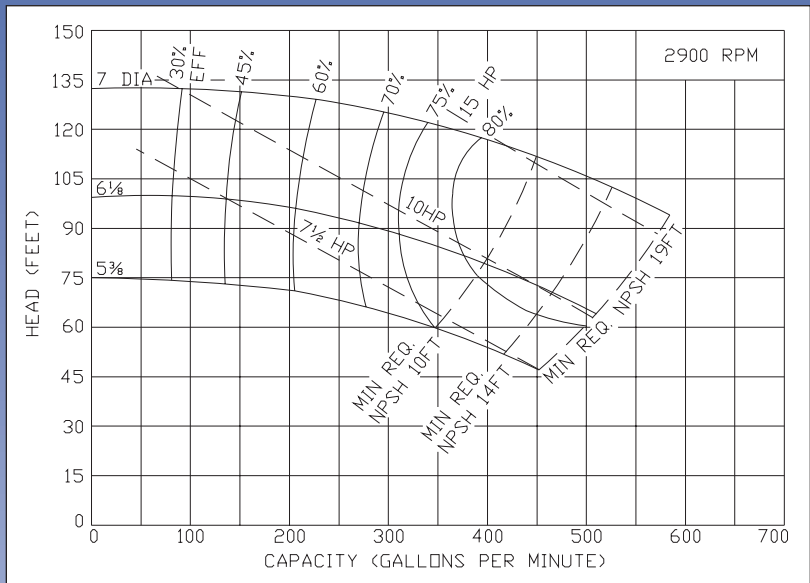

Ampco Pumps Company

4424 West Mitchell Street
 Milwaukee, Wisconsin 53214
 PHONE (414) 643-1852
 FAX (414) 643-4452