

Ampco Centrifugal Pumps

DATA SHEET

MODEL ZC2/ZCH2 3X2 1/2

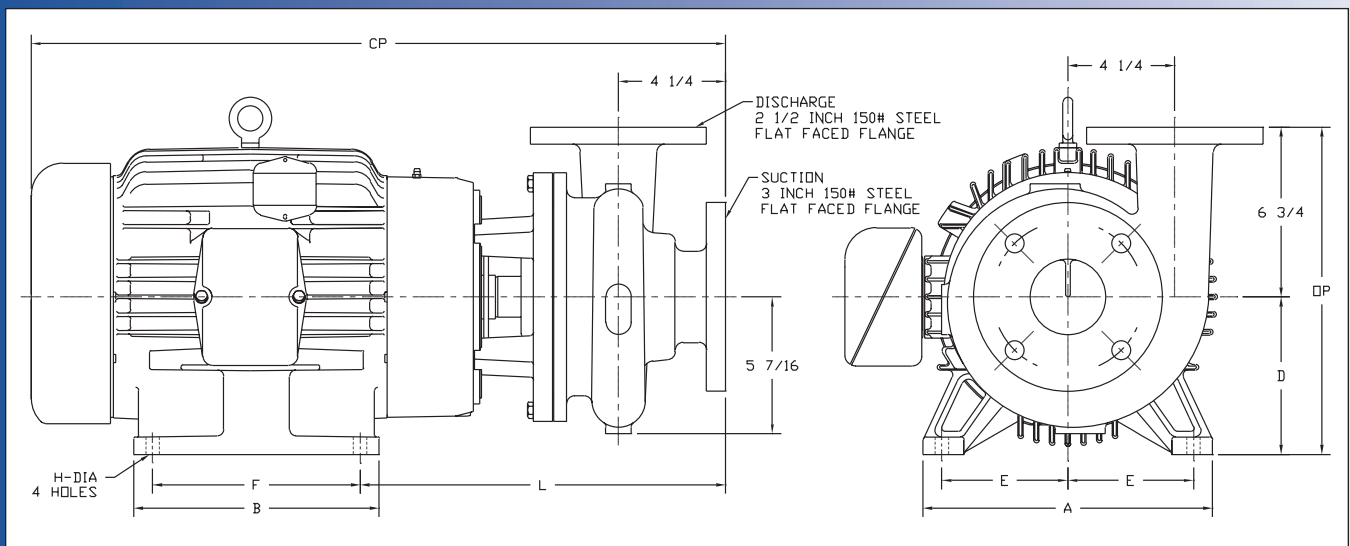
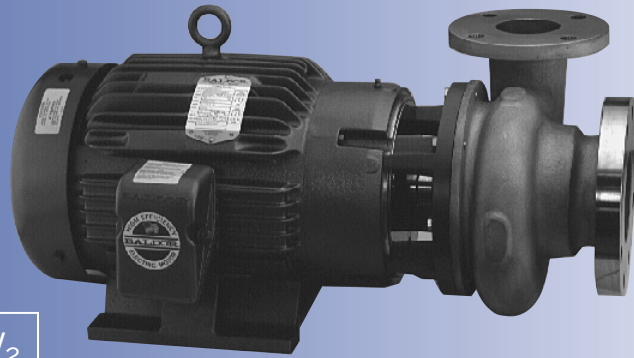

	TEFC MOTOR			DIMENSIONS IN INCHES (For Reference Only)									APPROX. WEIGHT (LBS)
	HP	RPM	FRAME	A (max)	B (max)	D	E	F	H	L	CP	OP	
ZC2	1	1750	143JM	6-1/2	6	3-1/2	2-3/4	4	11/32	11-5/8	19-15/16	10-1/4	129
ZC2	1-1/2	1750	145JM	6-1/2	6	3-1/2	2-3/4	5	11/32	11-5/8	19-15/16	10-1/4	133
ZC2	2	1750	145JM	6-1/2	6	3-1/2	2-3/4	5	11/32	11-5/8	19-15/16	10-1/4	139
ZC2	3	1750	182JM	8-5/8	6-1/2	4-1/2	3-3/4	4-1/2	13/32	12-1/4	21-5/16	11-1/4	165
ZC2	5	3500	184JM	8-5/8	6-1/2	4-1/2	3-3/4	5-1/2	13/32	12-1/4	22-11/16	11-1/4	178
ZC2	7-1/2	3500	213JM	9-5/8	8-1/8	5-1/4	4-1/4	5-1/2	13/32	13-1/4	25-9/16	12	246
ZC2	10	3500	215JM	9-5/8	8-1/8	5-1/4	4-1/4	7	13/32	13-1/4	25-9/16	12	264
ZCH2	15	3500	254JM	11-1/2	9-3/4	6-1/4	5	8-1/4	17/32	14-1/2	27-9/16	13	361
ZCH2	20	3500	256JM	11-1/2	11-1/2	6-1/4	5	10	17/32	14-1/2	29-3/8	13	399
ZCH2	25	3500	284JM	12-3/4	12-3/4	7	5-1/2	9-1/2	9/16	14-1/2	32-15/16	13-3/4	529

MATERIAL SPECIFICATIONS

PART NAME	NICKEL ALUMINUM BRONZE	STAINLESS STEEL
Casing, Cover & Impeller	AMPCO® 483	316 Stainless
Wear Ring	AMPCO® 18	316 Stainless
Motor Shaft	Steel	Steel
Shaft Sleeve	AMPCO® 18	316 Stainless
Adapter	Cast Iron	Cast Iron

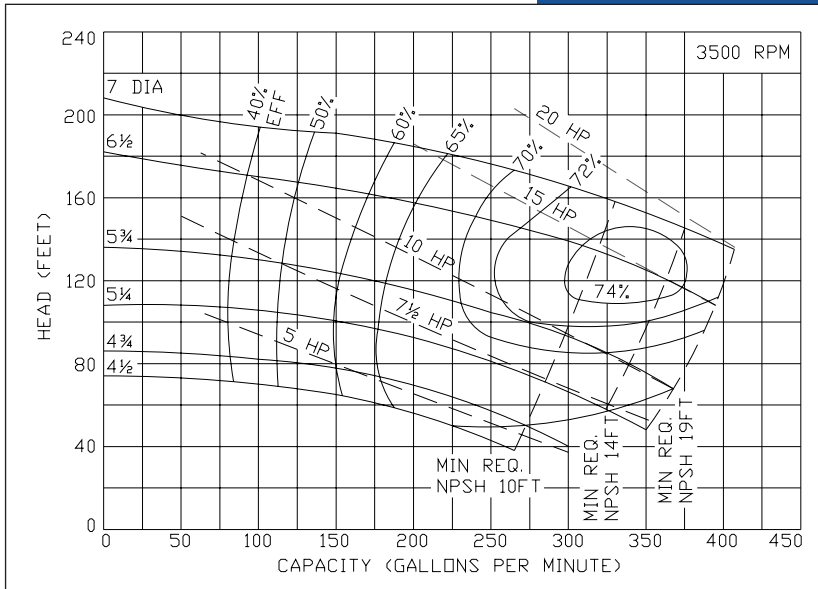

Ampco Centrifugal Pumps

MODEL ZC2/ZCH2 3X2¹/₂

Curves show approximate characteristics based on clear 68° water. Rated point is guaranteed.

Heavy-duty Z Series pumps have maximum wall thickness and 150 lb. flat faced flanged connections.

Seal options include Type 21, Type 1 and Type 9 with choice of sealing materials.

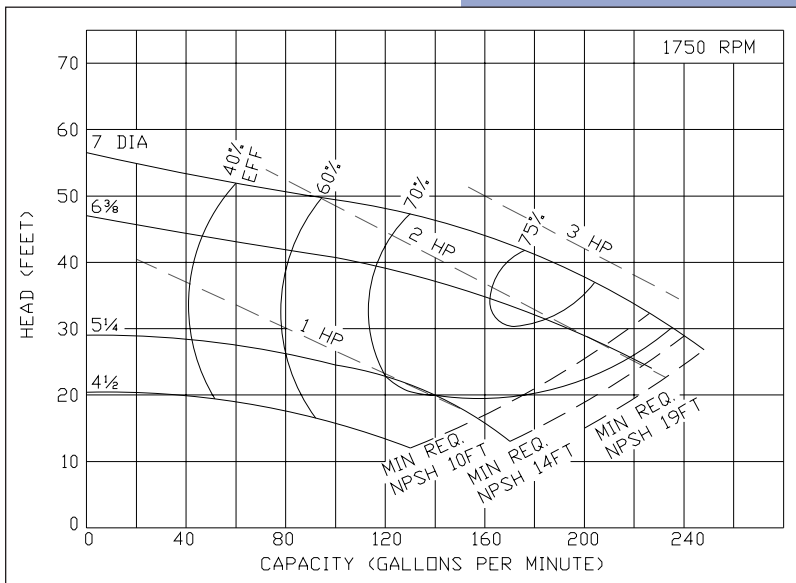
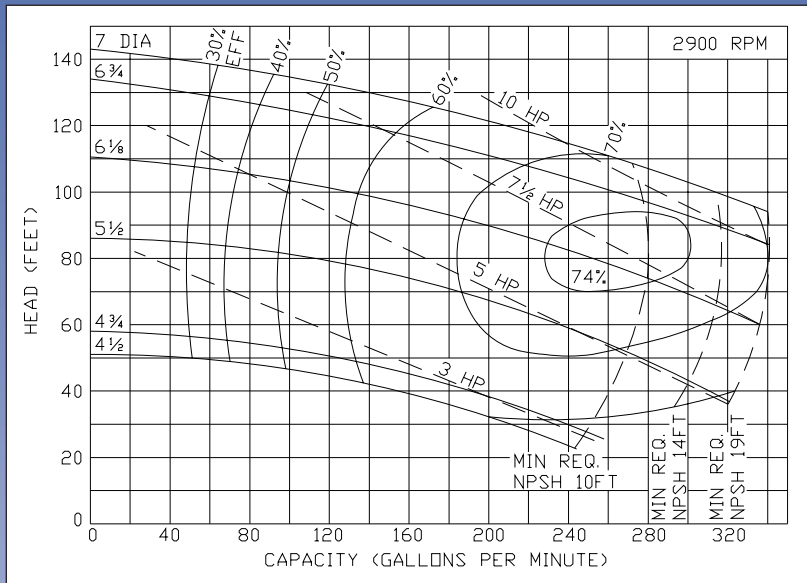

Ampco Pumps Company

4424 West Mitchell Street
 Milwaukee, Wisconsin 53214
 PHONE (414) 643-1852
 FAX (414) 643-4452