

# Ampco Centrifugal Pumps

## DATA SHEET

MODEL ZC2 2 X 1 1/2

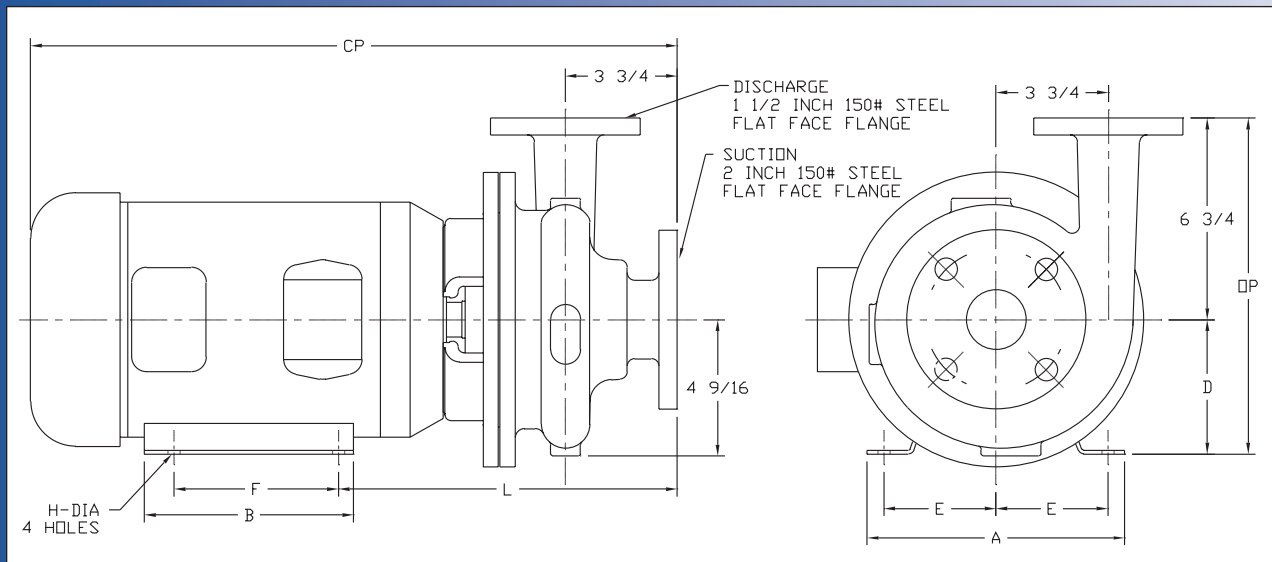

TEFC MOTOR			DIMENSIONS IN INCHES (For Reference Only)									APPROX. WEIGHT (LBS)
HP	RPM	FRAME	A (max)	B (max)	D	E	F	H	L	CP	OP	
1	1750	143JM	6-1/2	6	3-1/2	2-3/4	4	11/32	10-3/16	19-1/8	10-1/4	112
1-1/2	1750	145JM	6-1/2	6	3-1/2	2-3/4	5	11/32	10-3/16	19-1/8	10-1/4	116
2	1750	145JM	6-1/2	6	3-1/2	2-3/4	5	11/32	10-13/16	19-1/8	10-1/4	122
2	3500	145JM	6-1/2	6	3-1/2	2-3/4	5	11/32	10-13/16	19-1/8	10-1/4	122
3	3500	145JM	6-1/2	6	3-1/2	2-3/4	5	11/32	10-13/16	19-1/8	10-1/4	148
5	3500	184JM	8-5/8	6-1/2	4-1/2	3-3/4	5-1/2	13/32	11-7/16	21-15/16	11-1/4	161
7-1/2	3500	213JM	9-5/8	8-1/8	5-1/4	4-1/4	5-1/2	13/32	12-3/16	24-3/4	12	229
10	3500	215JM	9-5/8	8-1/8	5-1/4	4-1/4	7	13/32	12-3/16	24-3/4	12	247

## MATERIAL SPECIFICATIONS

PART NAME	NICKEL ALUMINUM BRONZE	STAINLESS STEEL
Casing, Cover & Impeller	AMPCO® 483	316 Stainless
Wear Ring	AMPCO® 18	316 Stainless
Motor Shaft	Steel	Steel
Shaft Sleeve	AMPCO® 18	316 Stainless
Adapter	Cast Iron	Cast Iron

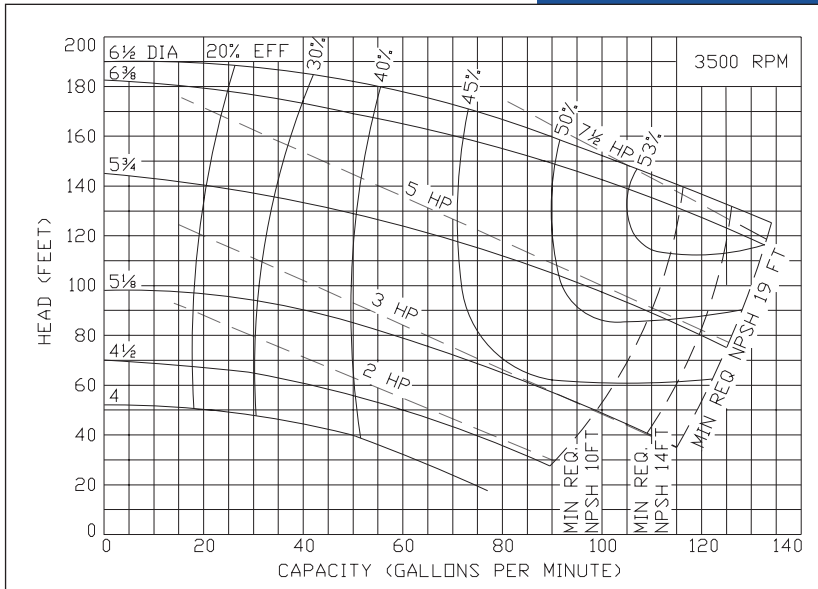

# Ampco Centrifugal Pumps

## MODEL ZC2 2 X 1 1/2

Curves show approximate characteristics based on clear 68° water. Rated point is guaranteed.

Heavy-duty Z Series pumps have maximum wall thickness and 150 lb. flat faced flanged connections.

Seal options include Type 21, Type 1 and Type 9 with choice of sealing materials.

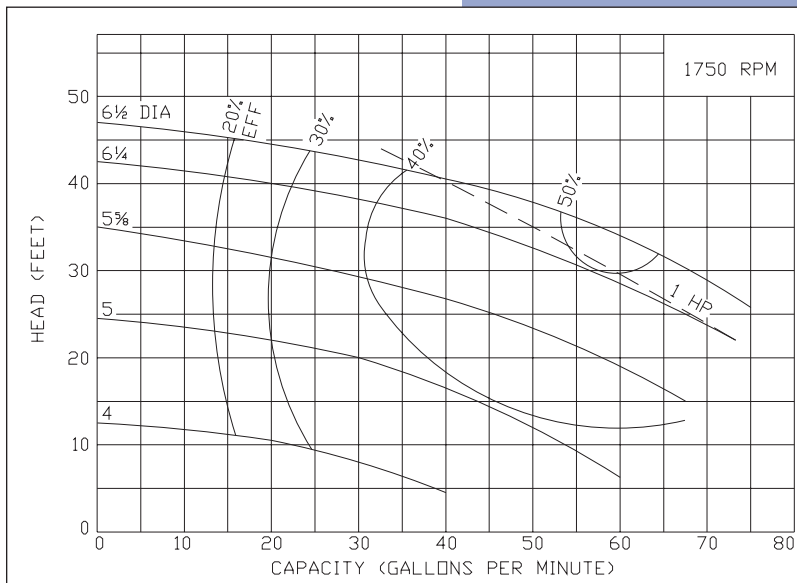
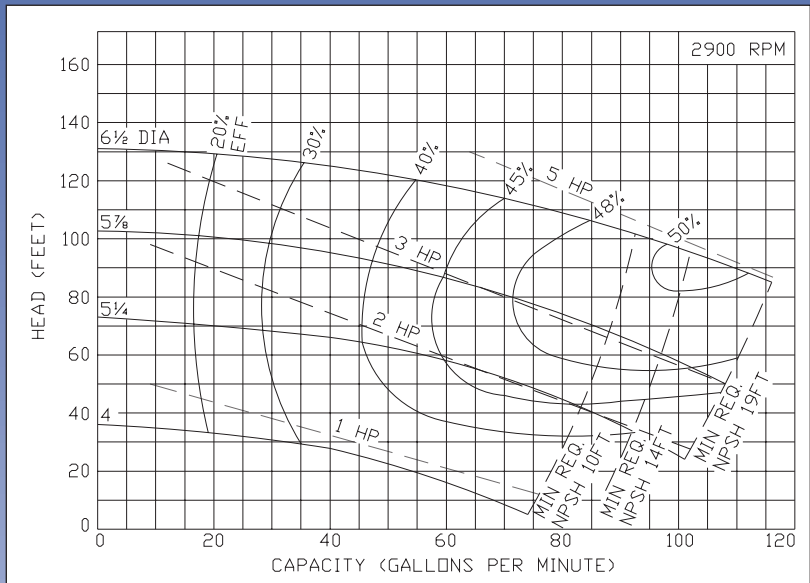

# Ampco Pumps Company

4424 West Mitchell Street  
Milwaukee, Wisconsin 53214  
PHONE (414) 643-1852  
FAX (414) 643-4452