

Ampco Centrifugal Pumps

DATA SHEET

MODEL RC2/RCH2 3X3X7

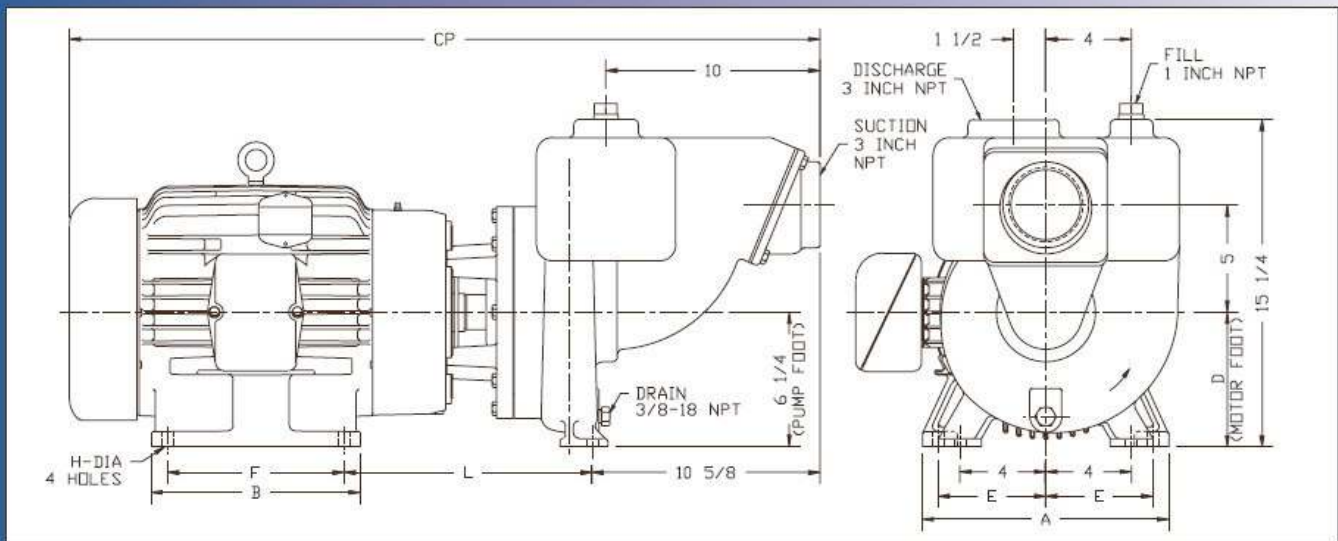

| TEFC MOTOR | | | DIMENSIONS IN INCHES (For Reference Only) | | | | | | | | APPROX. WEIGHT |
|------------|------|-------|---|---------|-------|-------|-------|-------|---------|---------|----------------|
| HP | RPM | FRAME | A (max) | B (max) | D | E | F | H | L | CP | |
| 2 | 1750 | 145JM | 6-1/2 | 6 | 3-1/2 | 2-3/4 | 5 | 11/32 | 8-7/16 | 27-1/2 | 154 |
| 3 | 1750 | 182JM | 8-5/8 | 6-1/2 | 4-1/2 | 3-3/4 | 4-1/2 | 13/32 | 9-1/16 | 28-3/4 | 180 |
| 5 | 1750 | 184JM | 8-5/8 | 6-1/2 | 4-1/2 | 3-3/4 | 5-1/2 | 13/32 | 9-1/16 | 30-1/4 | 193 |
| 15 | 3500 | 254JM | 11-1/2 | 9-3/4 | 6-1/4 | 5 | 8-1/4 | 17/32 | 11-9/16 | 35 | 376 |
| 20 | 3500 | 256JM | 11-1/2 | 11-1/2 | 6-1/4 | 5 | 10 | 17/32 | 11-9/16 | 36-3/4 | 414 |
| 25 | 3500 | 284JM | 12-3/4 | 12-3/4 | 7 | 5-1/2 | 9-1/2 | 17/32 | 11-9/16 | 40-9/16 | 544 |

MATERIAL SPECIFICATIONS

| PART NAME | NICKEL ALUMINUM BRONZE | STAINLESS STEEL |
|--------------------------|------------------------|---------------------|
| Casing, Impeller & Cover | AMPCO® 483 | 316 Stainless Steel |
| Shaft Sleeve | AMPCO® 18 | 316 Stainless Steel |
| Impeller Screw | AMPCO® 18 | 316 Stainless Steel |
| Motor Shaft | Steel | Steel |
| Adapter | Cast Iron | Cast Iron |

Ampco Centrifugal Pumps

MODEL RC2/RCH2 3X3X7

Curves show approximate characteristics based on clear 68° water. Rated point is guaranteed.

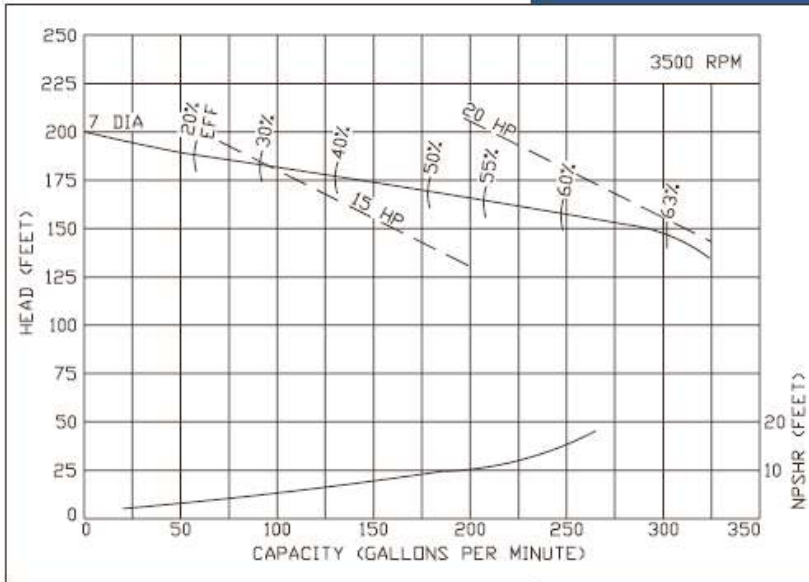

RC2/RCH2 self-priming pumps are close coupled to JM frame motors and have NPT threaded connections.

Seal options include Type 21, Type 1 and Type 9 with choice of sealing materials.

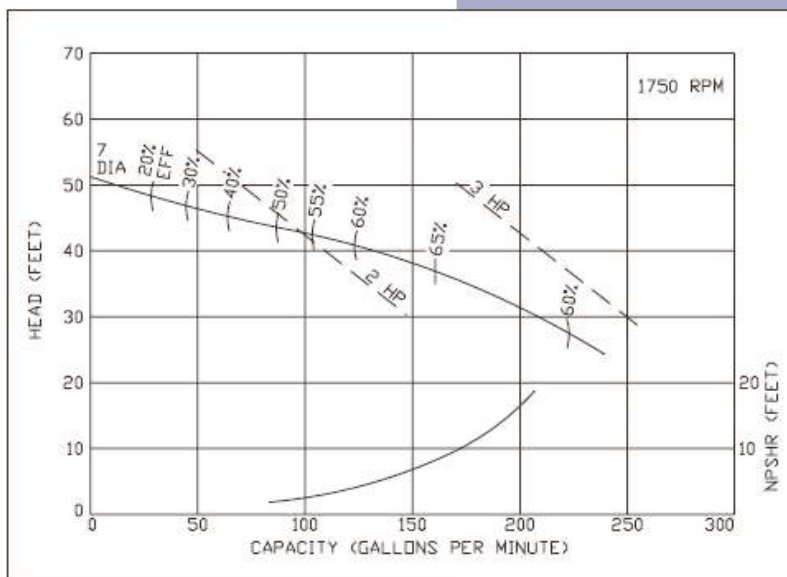
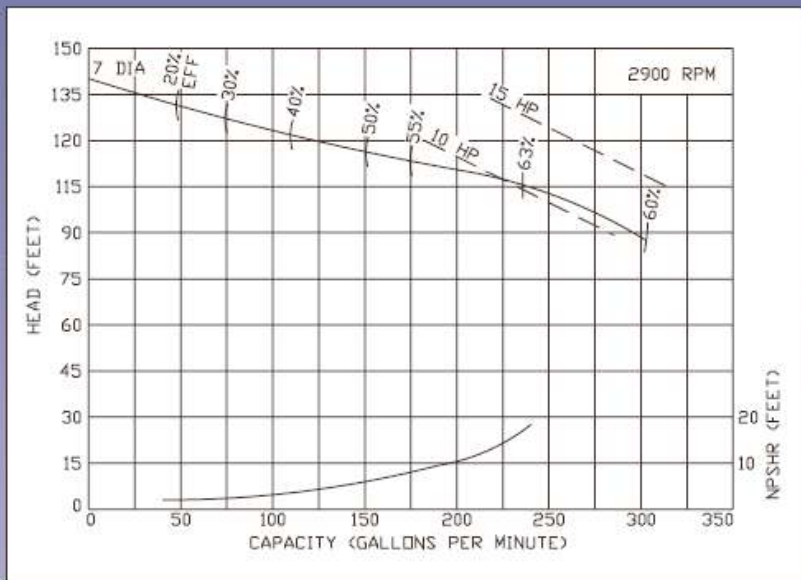

Ampco Pumps Company

4424 West Mitchell Street
 Milwaukee, Wisconsin 53214
 PHONE (414) 643-1852
 FAX (414) 643-4452