

Ampco Centrifugal Pumps

DATA SHEET

MODEL KF 1/2 X 1/4
STAINLESS STEEL

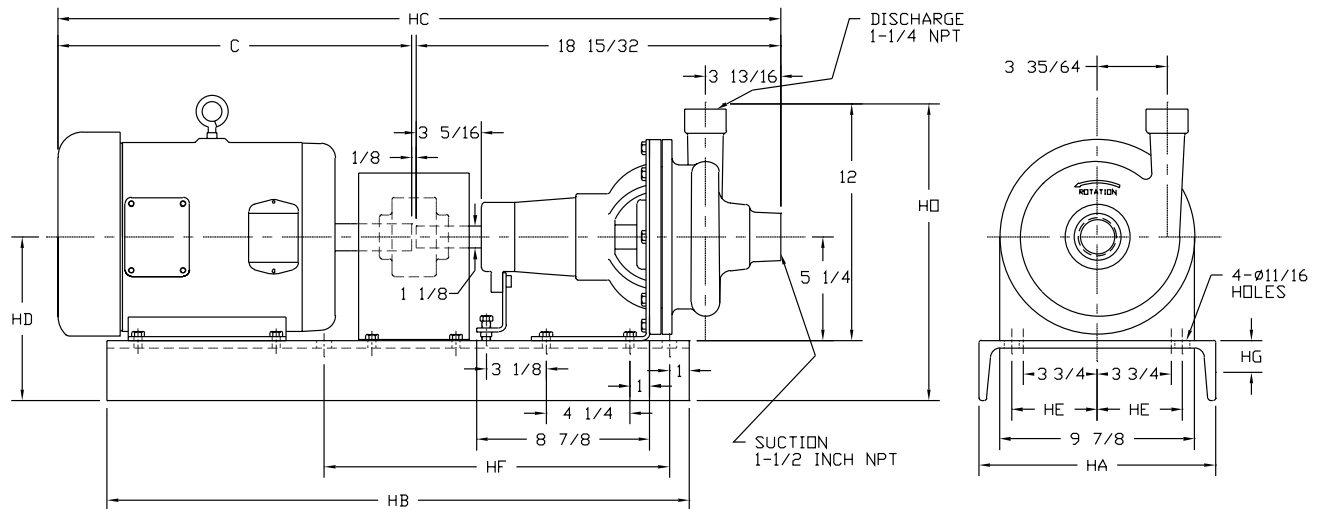
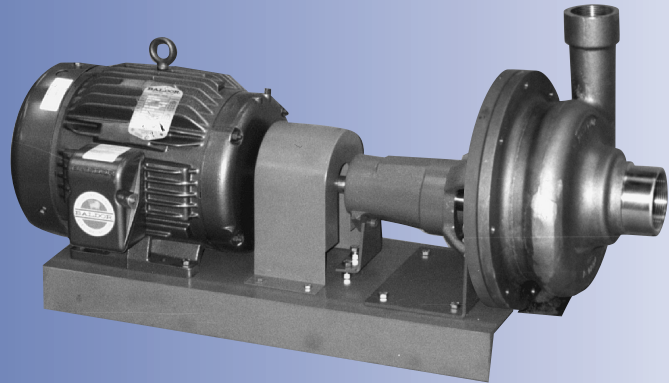

TEFC MOTOR			DIMENSIONS IN INCHES (For Reference Only)									
HP	RPM	FRAME	C	HA	HB	HC	HD	HE	HF	HG	HM	HO
1	1750	143T	13-1/16	10	26	31	7-7/8	3-3/4	24	2-5/8	11-3/4	14-3/8
2	3500	145T	13-1/16	10	26	31	7-7/8	3-3/4	24	2-5/8	11-3/4	14-3/8
3	3500	182T	15-3/8	10	26	33-5/16	7-7/8	3-3/4	16-1/4	2-5/8	12-1/2	14-3/8
5	3500	184T	15-3/8	10	26	33-5/16	7-7/8	3-3/4	16-1/4	2-5/8	12-1/2	14-3/8
7-1/2	3500	213T	19-7/16	12	28	37-3/8	8-1/4	4-1/2	17-1/2	3	13-3/4	14-3/4

MATERIAL SPECIFICATIONS

PART NAME	STAINLESS STEEL
Casing, Cover & Impeller	316 Stainless
Wear Ring	316 Stainless
Shaft	Steel
Shaft Sleeve	316 Stainless
Frame	Cast Iron

Ampco Centrifugal Pumps

MODEL KF 1½ X 1¼ STAINLESS STEEL

Curves show approximate characteristics based on clear 68° water. Rated point is guaranteed.

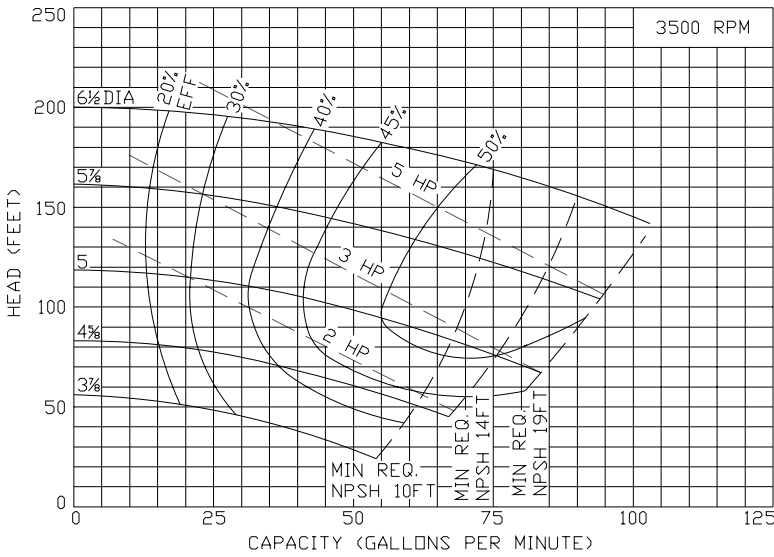

Standard K Series pumps have threaded NPT connections. Models 1½ x 1¼ and 2 x 1½ are mounted on JM frame motors and offer the same hydraulic performance as the comparable Z Series pump

Seal options include Type 21, Type 1 and Type 9 with choice of sealing materials.

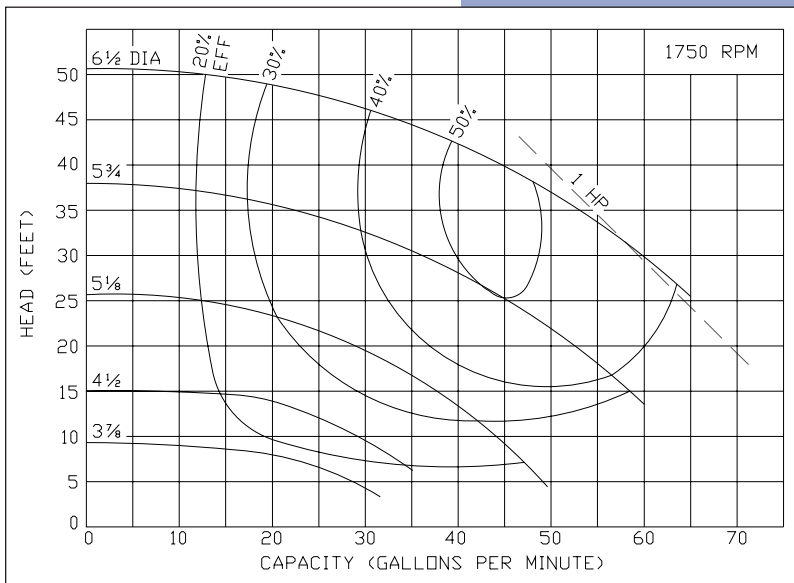
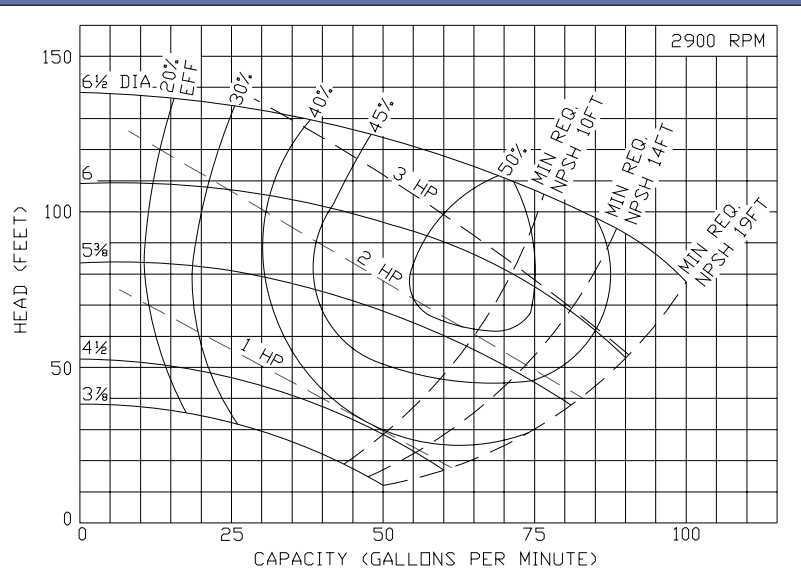

Ampco Pumps Company

4424 West Mitchell Street
 Milwaukee, Wisconsin 53214
 PHONE (414) 643-1852
 FAX (414) 643-4452