

Ampco Centrifugal Pumps

DATA SHEET

MODEL EP/EPH 4X3

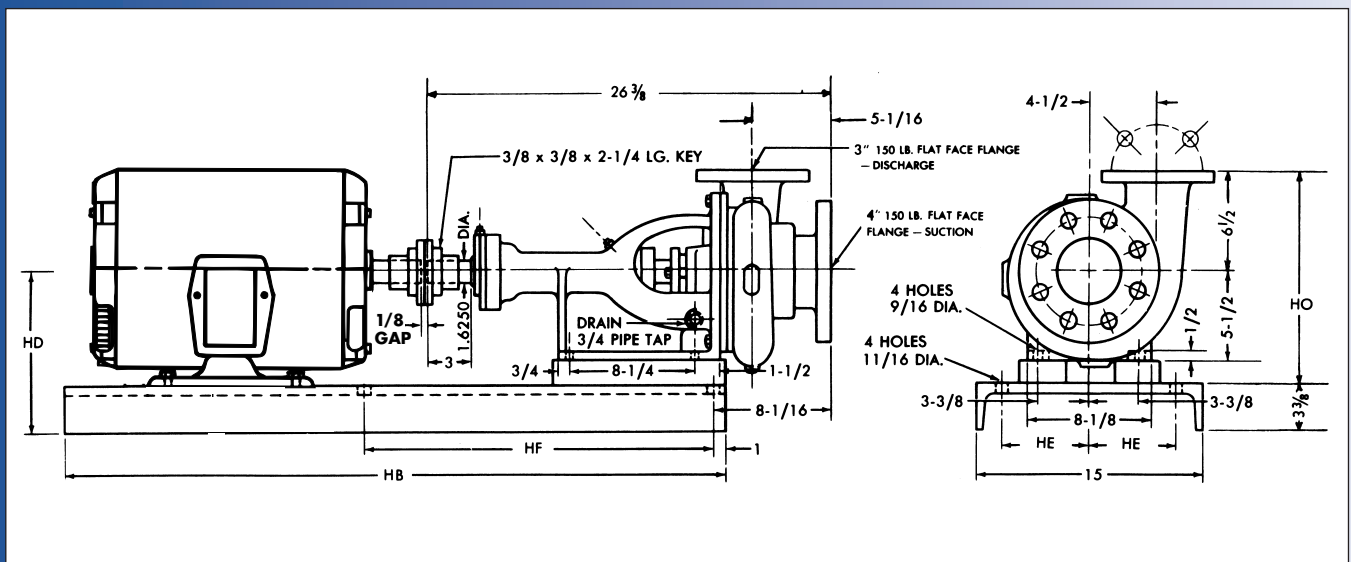
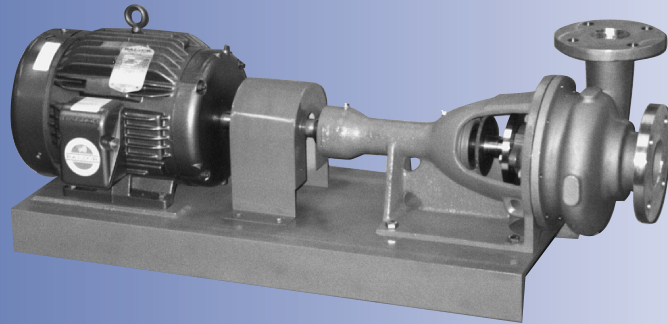

TEFC MOTOR			DIMENSIONS IN INCHES (For Reference Only)				
HP	RPM	FRAME	HB	HD	HE	HF	HO
10	3500	215T	36-3/4	8-7/8	6	19	15-3/8
15	3500	254T	41-1/2	9-5/8	6	23	16-1/8
20	3500	256T	41-1/2	9-5/8	6	23	16-1/8
25	3500	284TS	41-1/2	10-3/8	5-3/4	23	16-7/8
30	3500	286TS	41-1/2	10-3/8	5-3/4	23	16-7/8

MATERIAL SPECIFICATIONS

PART NAME	NICKEL ALUMINUM BRONZE	STAINLESS STEEL
Casing, Cover & Impeller	AMPCO® 483	316 Stainless
Wear Ring	AMPCO® 18	316 Stainless
Shaft	Steel	Steel
Shaft Sleeve	AMPCO® 18	316 Stainless
Frame	Cast Iron	Cast Iron

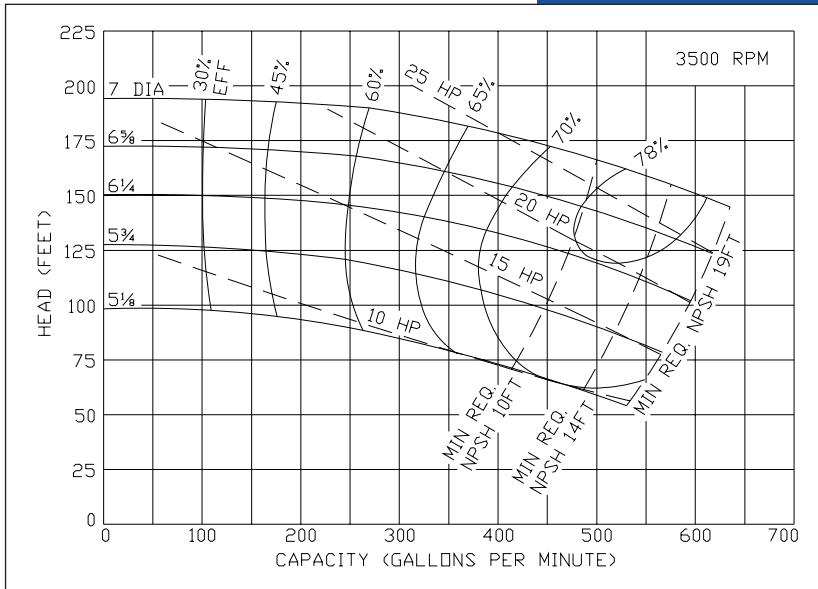

Ampco Centrifugal Pumps

MODEL EP/EPH 4x3

Curves show approximate characteristics based on clear 68° water. Rated point is guaranteed.

E Series pumps provide the same heavy-duty construction and hydraulic performance as Ampco's Z Series.

An enlarged stuffing box offers multiple sealing arrangements, including Type 21, Type 1, Type 9, Double Type 21, Double Type 9, packing and cartridge seals.

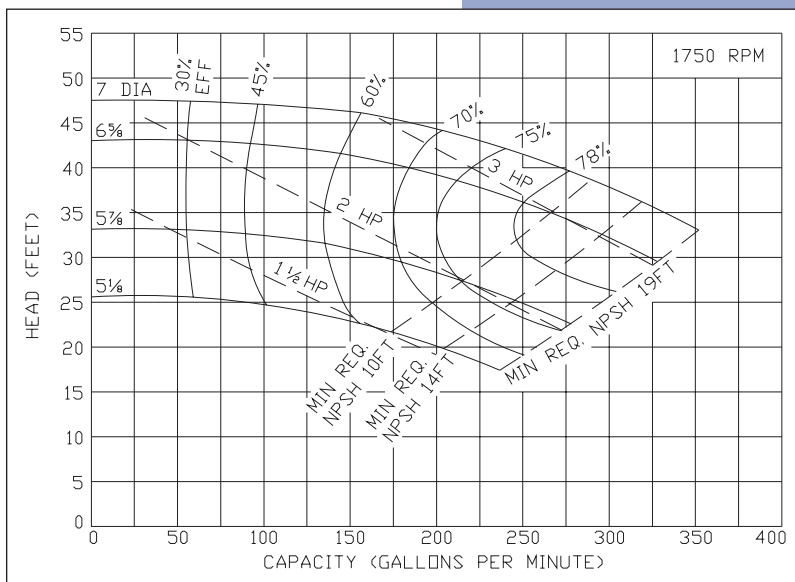
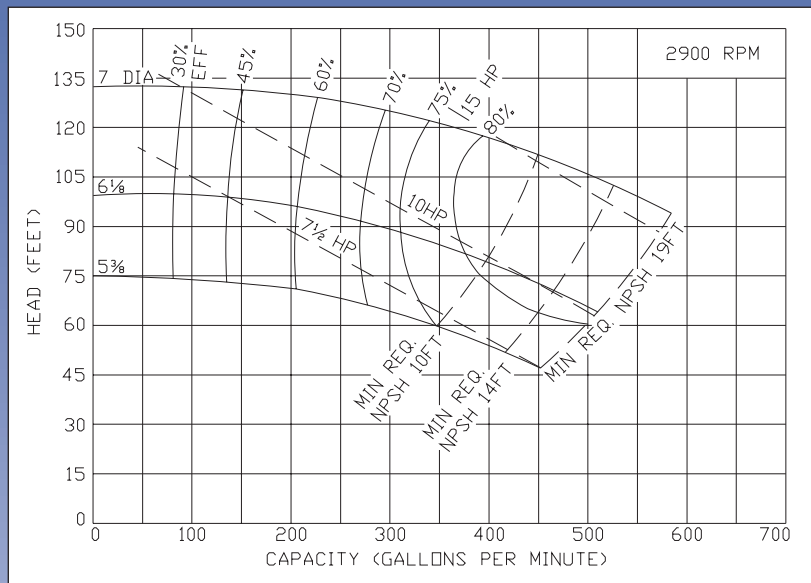

Ampco Pumps Company

4424 West Mitchell Street
 Milwaukee, Wisconsin 53214
 PHONE (414) 643-1852
 FAX (414) 643-4452