

Ampco Centrifugal Pumps

MODEL EP 2 1/2 X 2

Curves show approximate characteristics based on clear 68° water. Rated point is guaranteed.

E Series pumps provide the same heavy-duty construction and hydraulic performance as Ampco's Z Series.

An enlarged stuffing box offers multiple sealing arrangements, including Type 21, Type 1, Type 9, Double Type 21, Double Type 9, packing and cartridge seals.

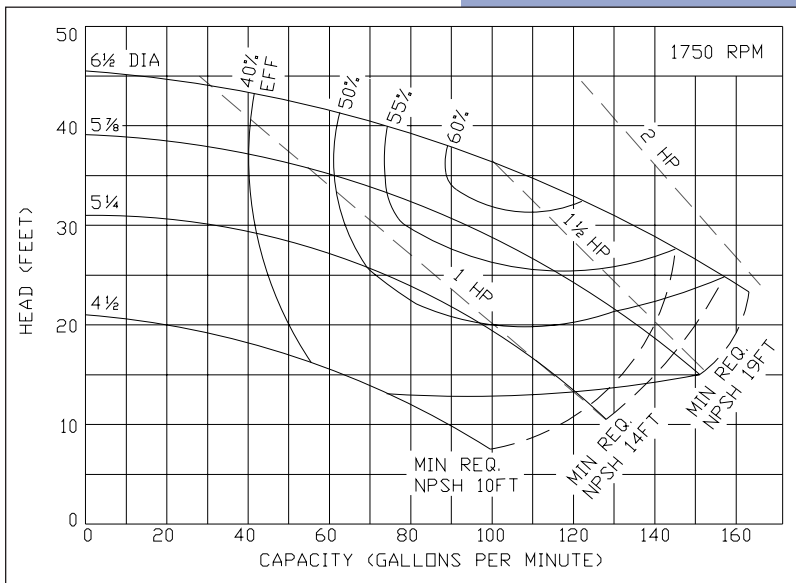
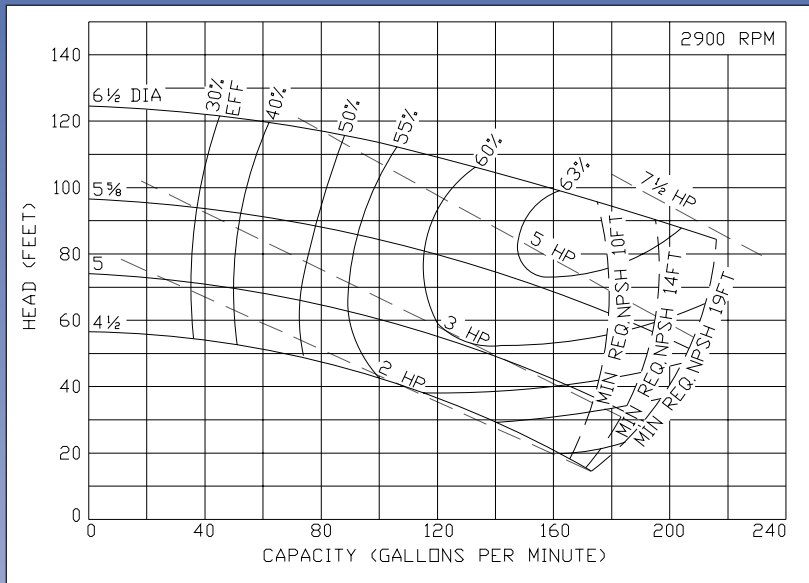

Ampco Pumps Company

4424 West Mitchell Street
 Milwaukee, Wisconsin 53214
 PHONE (414) 643-1852
 FAX (414) 643-4452