

Ampco Centrifugal Pumps

DATA SHEET

MODEL DC2/DCH2 4X3
MODEL DC3/DCH3 4X3

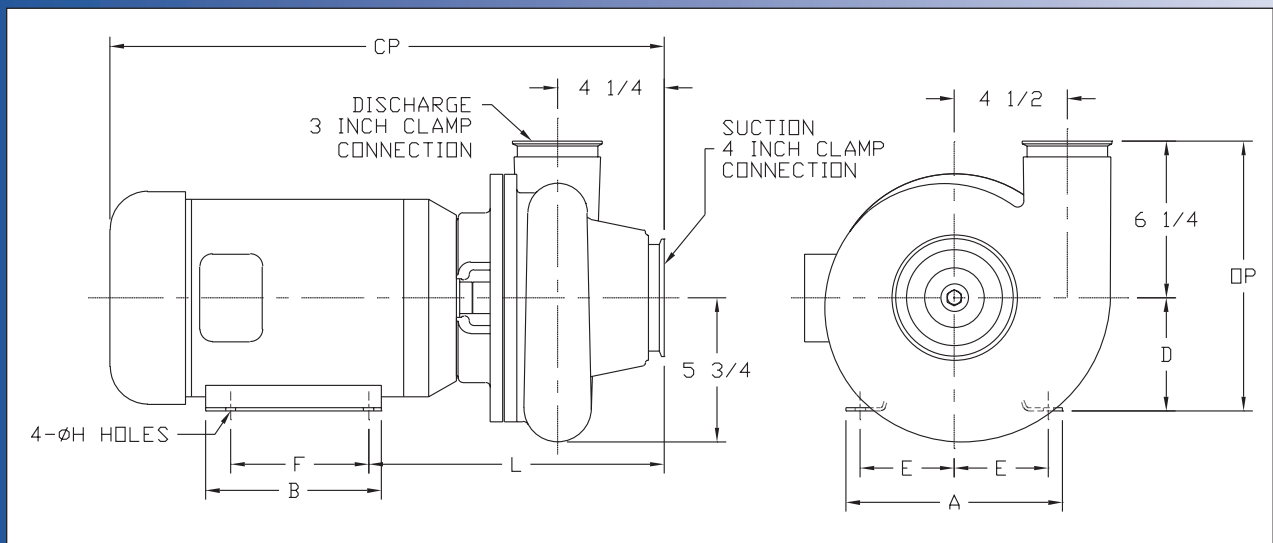
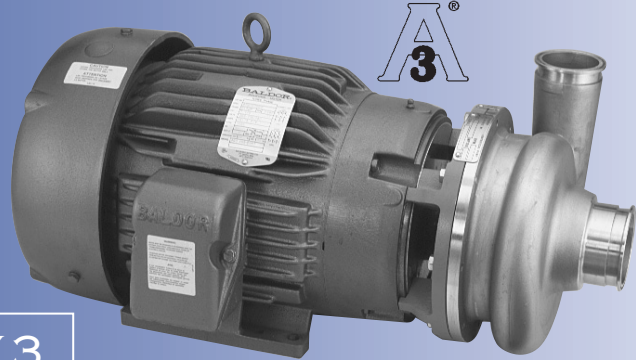

	TEFC MOTOR			DIMENSIONS IN INCHES (For Reference Only)									APPROX. WEIGHT (LBS)
	HP	RPM	FRAME	A (typ)	B (typ)	D	E	F	H	L	CP	OP	
DC2	2	1750	145JM	6-1/2	6	3-1/2	2-3/4	5	11/32	11-7/32	19-17/32	9-3/4	155
DC2	3	1750	182JM	8-5/8	6-1/2	4-1/2	3-3/4	5-1/2	13/32	11-27/32	20-29/32	10-3/4	167
DC2	5	1750	184JM	8-5/8	6-1/2	5-1/4	4-1/4	5-1/2	13/32	11-27/32	22-7/16	10-3/4	191
DC2	10	3500	215JM	9-1/2	8	5-1/4	4-1/4	7	13/32	12-27/32	23-5/32	11-1/2	258
DCH2	15	3500	254JM	11-1/2	9-3/4	6-1/4	5	8-1/4	17/32	14-11/32	27-5/32	12-1/2	379
DCH2	20	3500	256JM	11-1/2	11-1/2	6-1/4	5	10	17/32	14-11/32	29	12-1/2	398
DCH2	25	3500	284JM	12-3/4	12-3/4	7	5-1/2	9-1/2	9/16	14-11/32	32-17/32	13-1/4	533
DCH2	30	3500	286JM	12-3/4	12-3/4	7	5-1/2	11	9/16	14-11/32	33-5/32	13-1/4	662

MATERIAL SPECIFICATIONS

PART NAME	STAINLESS STEEL
Casing & Cover	316 Stainless
Impeller	316 Stainless
Motor Shaft	Steel
Shaft Sleeve	316 Stainless
Adapter	Cast Iron

Ampco Centrifugal Pumps

MODEL DC2/DCH2 4X3
MODEL DC3/DCH3 4X3

Curves show approximate characteristics
based on clear 68° water.
Rated point is guaranteed.

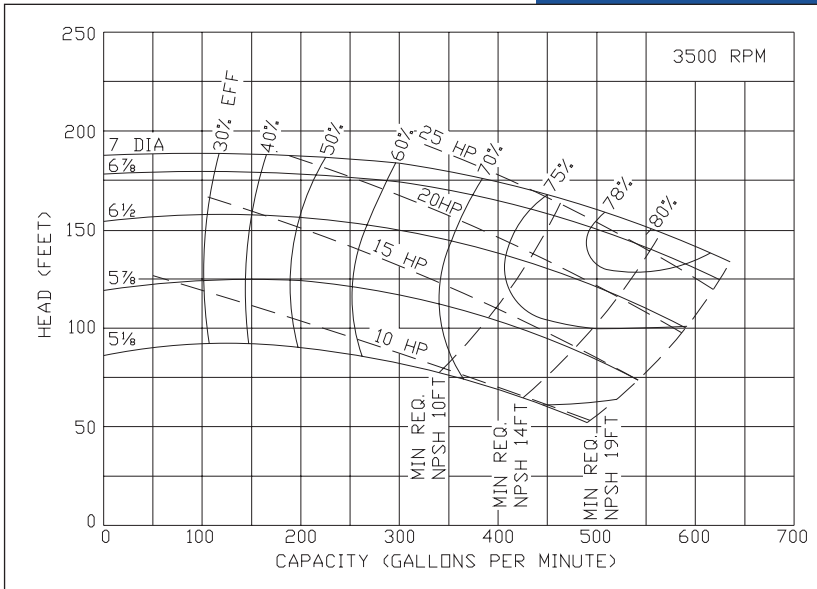

DC3/DCH3 pumps are in conformance with 3A sanitary standards for centrifugal and positive rotary pumps for pumping cleaning and sanitizing solutions, Number 47-00.

DC2/DCH2 pumps are also available with 150 lb. flat faced flanged connections.

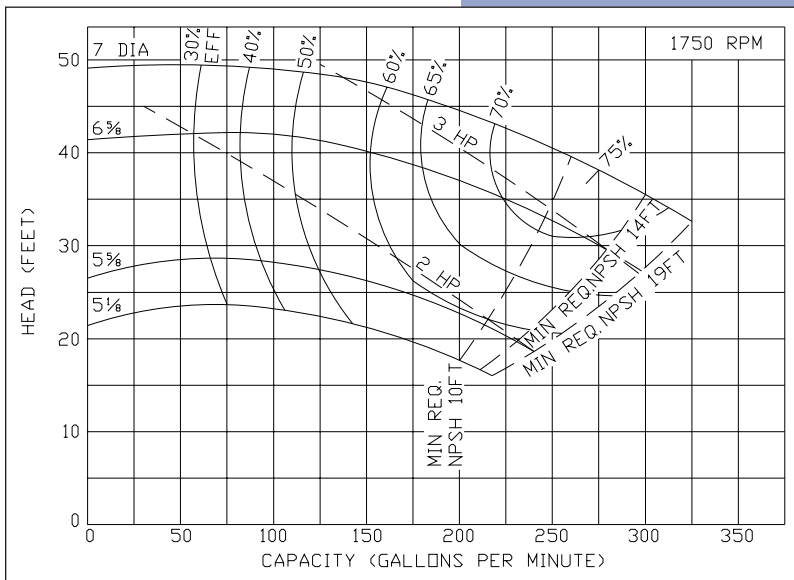
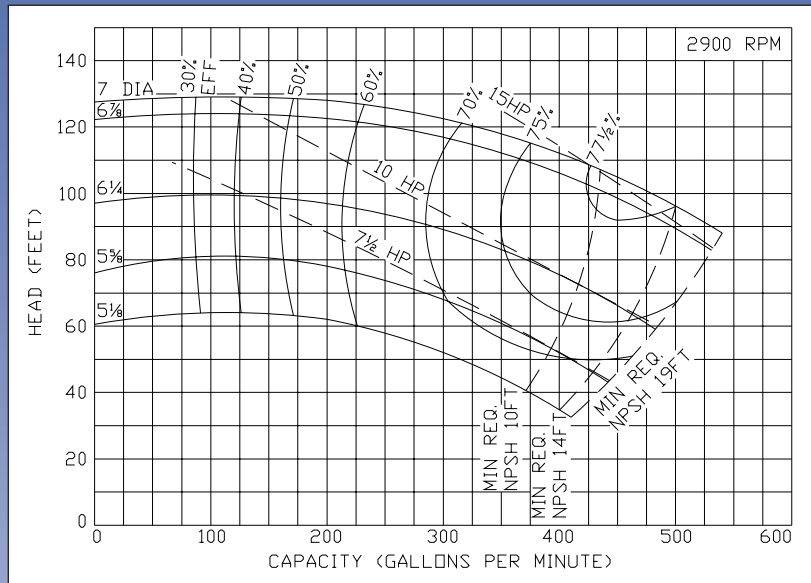

Ampco Pumps Company

4424 West Mitchell Street
Milwaukee, Wisconsin 53214
PHONE (414) 643-1852
FAX (414) 643-4452