

# INSTALLATION AND MAINTENANCE OF AMPCO CENTRIFUGAL PUMPS

## INSTRUCTIONS

Your Ampco centrifugal pump is a rugged unit designed to provide years of low cost pumping service. There is a small amount of necessary care required to ensure you of this expected long service. It is recommended that you carefully review the installation and operating sections in this manual.

Every Ampco pump receives a careful running test at the factory to ensure that the head-capacity rating is met in accordance the Hydraulic Institute Standards and to ensure mechanical soundness. Special instructions and advice for unusual conditions, such as corrosive, abrasive, and other problems are too numerous to be included in this general book, but will be the subject of specific discussion on orders or inquires for special applications.

## LOCATION

The immediate environment, in which the unit is located, while usually of prime importance to the pump, may determine the enclosure needed for the motor. Ampco can supply several different motor enclosures to meet specific requirements.

The LF Series pumps series are supplied with totally enclosed motors as standard. They may be installed where dirt, moisture and mild corrosion are present or in outdoor locations. Wash-down duty motors, with epoxy paint or paint free stainless steel, are designed for applications where the motor is frequently subject to washdown to maintain a bacteria-free operating environment. Specialty motors may be required for moist, corrosive, or explosive environments. Motor drain plugs (if not equipped with automatic drains) must be removed periodically to drain accumulated condensation.

Pump units should be located where daily visual inspection is possible and no surrounding structure interferes with ventilating air over or through the motor.

Submerged suction is the most economical and convenient method of priming a pump when installed in such a position that the top of the casing is below the surface of the liquid to be pumped. The liquid will flow by gravity into the pump and displace the air (through the discharge if possible or a vent when available).

## INSTALLATION

Begin with a suction line as direct and as simple as possible. The suction line is usually the most sensitive part of the entire pumping system being totally dependent on outside forces to provide liquid flow into the center of the impeller.

Locate the pump as close to the supply of liquid as possible, with short and direct suction piping. Use wide radius elbows to help reduce friction loss. Air pockets due to high sections, concentric reducers, valve bonnets, etc. should be eliminated by installing a suction having a continual rise or at very least a straight horizontal run with an air eliminator near the pump suction entry. To prevent air pockets use eccentric pipe reducers that are mounted in a horizontal position across the top of the pipeline and valves that can be positioned in a plane rather than the normal upright position as an air pocket may exist in the upright valve bonnet.

## LF SERIES PUMPS

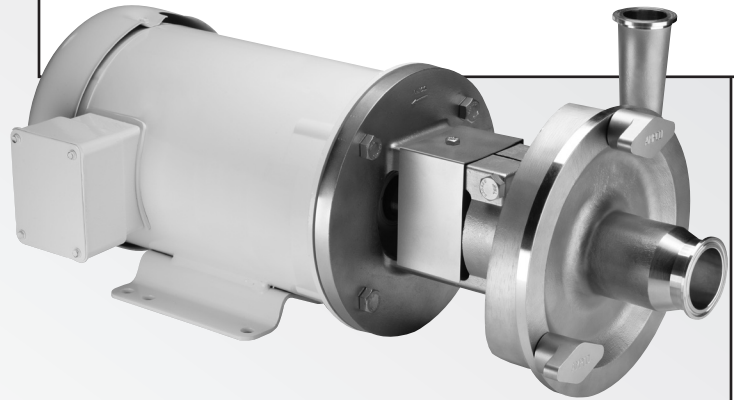

Above all, remember that until the liquid reaches the leading edges of the rotating impeller vane the pump cannot impart its energy to move the liquid.

If possible, try not to connect an elbow directly to the inlet of the pump. This may cause excessive turbulence and hinder pump performance.

## STARTING

The pump must be primed before starting, as the mechanical seal depends on the liquid being pumped for lubrication and cooling. Even a short run to determine direction of rotation without first priming may seriously damage the seal.

The correct direction of rotation is counter-clockwise when viewed from the suction end of the pump. It is recommended to turn the pump by hand before starting the first time to ensure the unit is not binding.

## MAINTENANCE

Since long-term breakdown cannot be tolerated in most services, maintenance procedures and a contingency plan must be established in advance to minimize any production loss caused by down time.

During building and start-up it is common to use outside personnel. Operating personnel should acquaint themselves with the pump, particularly its running performance. This will aid in establishing a standard for future reference. This manual and other information provided with the pump should be filed for future reference.

All possible performance data should be recorded once the system is functioning properly and stable. Suction and discharge pressure readings, flow rate, seal leakage rate, bearing temperature, noise and vibration levels all provide input to a pump's performance in the system. It is unlikely that all of this data can be measured, but any information gathered can help alert the user of problems with the pump or system.

Operating personnel should know that any changes in the system or the liquid being pumped might have an effect on the pump's performance. It is advisable to also record the fluid temperature, specific gravity, viscosity, liquid concentration,

## Front Loading Mechanical Seal

percent of solid concentration, other additives and properties. A proper maintenance procedure should begin with a file for each pump. All known data relative to the pump, fluid handled and system should be included. Complete records of maintenance and repair costs along with a log of the unit's operating hours should be kept.

In addition, complete pump identification- size, type, operating speed, manufacturer, serial number, model number, and material of construction should be noted.

### Maintenance Procedures

Daily Check-possibly the most important inspection will be the daily observation.

1. Seal leakage rate
2. Pressure reading and flow indication
3. Change in operating sound
4. Change in bearing temperature
5. Check to make sure flow is going through the double seal flush lines

Semi-Annual Inspection-typically made at 6-month intervals with results noted in pump's maintenance file.

1. Check of mechanical seal assembly
2. Check of bearing lubrication

Annual Inspection-includes Semi-Annual inspection plus:

3. Removal of seal for inspection
4. Bearing Check
5. Check of axis/running clearance of impeller

### Contingency Plan

For inspection findings and breakdowns, a contingency plan should be developed. To begin with, an adequate supply of probable replacement parts should be kept on hand.

The minimum recommended spare parts are as follows:

1. Mechanical seal kit (complete with o-ring set)
2. Volute casing o-ring
3. Impeller Key

In addition Ampco recommends

4. Impeller
5. Impeller Nut

Where service cannot be interrupted, a complete stand-by pump unit fully assembled (and in a by-pass line) is recommended.

### **DISMANTLE AND REPLACE PARTS AS FOLLOWS:**

Before attempting any service on the pump or motor, disconnect or lock out electrical power to the pump motor. If the pump and motor are to be removed as a unit, note the wiring configuration. Use colored or numbered tape to mark the wire connections of the motor and power source, for reconnection.

These instructions are limited to fluid ends only. See other drawings and literature applicable to motors, pedestals, frames, shafts, bearings, etc., if additional repairs are required.

1. Disconnect pump from both suction and discharge piping. Remove the shaft cover guard at this time by taking off the cover guard bolt.
2. Remove cover by taking off casing nuts. A rubber mallet may be necessary to loosen the nuts.
3. Remove the impeller nut using a 15/16" socket and holding the stub shaft with a 3/8" rod in the predrilled hole. Ease the impeller off the shaft. Pinch bars between the impeller and cover may be required. Be careful not to mar the pump's surface finish. Remove the impeller key by compressing the seal.

4. Remove all mechanical seal components by simply pulling them off the shaft. In order to remove the seal components, it may be necessary to reach around to the back side of the pump casing and push the seal towards the narrow end of the stub shaft using your fingertips.

5. (For double seals only ) Remove the external double seal components from the stub shaft.

6. Thoroughly clean the seal cavity and shaft and dry with a clean cloth.

**The Mechanical seal is the only expendable pump part. It is suggested that the complete mechanical seal, both stationary and rotating members, be replaced whenever dripping or leakage occurs at the shaft, or whenever parts are removed to the point of separating the primary sealing surfaces.**

*The fluid end is now completely dismantled: Additional procedures are dictated by purpose for which unit was dissembled.*

### Mechanical Seal Replacement and Reassembly

Please see the table on page 5 for proper identification of all seal components. The numbers in parenthesis refer to the diagram on page 5 for mechanical seal components.

1. (For double seals only) Place the o-ring (2) into the double rotating seal (3) and lubricate sufficiently. Install the wave spring (1) behind the 3 mm shaft pins and then push the rotating seal (3) on to the shaft, making certain to engage the slots in the seal with the pins on the shaft.

2. Place the stationary seal o-ring (6) in the groove on the single stationary seal (5) and lubricate sufficiently. If necessary, repeat for double stationary seal o-ring (4).

3. Place the stationary seal (5) in the pump housing. The seal is keyed such that it must be installed with the protruding square flats aligned with the square pocket that is milled into the housing.

4. Install the wave spring (9) behind the 3mm pins on the inside surface of the seal driver.

5. Place single rotating seal o-ring (8) in the groove on the single rotating seal (7) and lubricate sufficiently.

6. Install the rotating seal/o-ring assembly from step 5 into the seal driver, making certain to engage the slots on the seal with the pins on the seal driver.

7. Slide the inner seal driver o-ring (10) onto the shaft and lubricate sufficiently.

8. Slide the seal driver/rotating seal assembly from step 6 onto the shaft.

9. Place the outer seal driver o-ring (12) in the o-ring groove on the seal driver and lubricate sufficiently.

10. Place impeller key in the slot on the shaft

11. Install the impeller nut gasket onto the impeller nut and lubricate sufficiently.

12. Slide the impeller onto the shaft, making certain to align the keyway with the key that was installed in step 10.

13. Thread the impeller nut/gasket assembly from step 11 to the shaft finger-tight. Place a 3/8" rod in the shaft hole and use a 15/16" socket with a torque wrench to tighten the nut to 40 ft-lbs. Rotate the impeller by hand to verify that it is spinning freely.

14. Install the cover o-ring and lubricate sufficiently.

15. Secure the cover to the casing using the wing nuts. Tighten the wing nuts hand-tight and then provide additional tightening by tapping the nuts gently with a soft faced hammer.

**One way to damage a new seals to run it dry. Be sure the pump is in place and primed before operating.**

16. Place the pump back into service and inspect for proper rotation and leaks.

## Pump Shaft Replacement

If the pump stub shaft is being replaced, it is recommended that new shaft collar also be installed.

1. Begin with pump disassembly as directed previously.

2. (Cinch-type adapters only) If the water cascade option has been ordered, use a channel locks or pipe wrench to remove the water pipes. Use two 3/4" wrenches to loosen the adapter clamping bolt and nut. The gap can be widened if necessary by using a flat blade screwdriver. Once the cinch fit has been loosened, remove the pump casing.

2a. (Flange-type adapters only) If the water cascade option has been ordered, use a channel locks or pipe wrench to remove the water pipes. Use a 3/4" socket to remove the housing bolts and washers, and then remove the pump casing.

3. Loosen the shaft collar with an allen wrench (3/16", 1/4", or 3/8": see sizes in table on page 5) so that the stub shaft can be taken off the motor. A rubber mallet may be used to tap the stub shaft if it will not slide off. Be careful not to drop the shaft collar when the stub shaft comes off the motor.

3a. If the stub shaft does not come off, the volute, impeller, impeller nut gasket, and impeller nut may be assembled onto the shaft to help pull the stub shaft off (make sure that all the seal pieces are out of the volute). A cloth between the volute casing and impeller is necessary in this step. Pull on the volute or gently tap it with a rubber mallet to create enough force to free the stub shaft from the motor.

4. Slide the new shaft collar onto the new stub shaft and slide the two together onto the motor shaft, keeping the motor keyway in line with the 3/8" hole on the stub shaft. If the collar has an identification groove in it, this will rest against the step in the stub shaft.

5. Line up the slot in the collar with the stub shaft slot. Do not tighten the shaft collar yet. Since the shaft was disassembled, the impeller clearance in the volute may have changed. The impeller must be repositioned for proper pump performance and to insure that the impeller with not rub.

6. Slide the volute over the pump shaft and shoulder it against the adapter.

7. Using two 3/4" wrenches, tighten the adapter bolt to secure the volute, making sure the pump discharge is aligned for the piping. For pumps with frame sizes 280 or larger use a 3/4" wrench to tighten all bolts between the volute and the adapter

8. Install the seal, impeller, and impeller nut as described in steps 1 - 13 of the previous procedure.

9. The critical impeller gap is the gap between the volute and the nearest impeller blade to it. This will be measured using a feeler gauge. The blades may not all be at the same distance due to manufacturing and balance procedures. Please see the table on page 5 for the correct impeller gaps.

10. With a rubber mallet, gently tap the impeller nut to drive the stub shaft towards the motor while the feeler gauge is between the impeller and volute. This will create the critical impeller gap.

11. When the impeller gap is correct, align the shaft collar slot with the slot in the stub shaft and the motor shaft keyway and tighten the shaft collar with an Allen wrench (3/16", 1/4", or 3/8": see sizes in table on page 5) to secure the shaft position.

12. Remove the feeler gauge and re-install the cover o-ring, cover and wing nuts.

## Motor Replacement

Before attempting any service on the pump or motor disconnect or lock out electrical power to the pump motor. If the pump and motor are to be removed as a unit, note the wiring configuration. Use colored or numbered tape to mark the wire connections of the motor and power source, for reconnection.

1. Begin disassembling the pump by removing the impeller and seal components as described in steps 1-6 of the prior dismantling procedure.

2. Remove the housing and shaft as described in steps 23 of the pump shaft replacement procedure.

3. Remove the adapter bolts and washers using a socket or box wrench and then separate the adapter from the motor.

4. Use a socket or box wrench to bolt the adapter to the new motor. Make certain to install the washers and bolts in the proper sequence.

5. Install the shaft, impeller, seal, housing and cover as described in steps 4-12 of the shaft replacement procedure.

6. Replace the shaft guards. If the water cascade option has been ordered, replace the water pipes.

# Front Loading Mechanical Seal

AMPCO PUMPS COMPANY  
PARTS BREAKDOWN

DETAIL NO.	REQ. NO.	PART NAME
24B	1	ADAPTER TIGHTENING BOLT
24A	1	ADAPTER NUT
21	1	SHAFT COLLAR
20	X <sup>2</sup>	WING NUT
19	1	MOTOR
17	4	CAP SCREW (MOTOR/ADAPTER)
16 <sup>1</sup>	2	DRIVE SCREW
15 <sup>1</sup>	1	NAME PLATE
13B <sup>1</sup>	1	DOUBLE MECHANICAL SEAL
13A	1	SINGLE MECHANICAL SEAL

DETAIL NO.	REQ. NO.	PART NAME
12	1	IMPELLER KEY
11B	1	CAP SCREW (SHAFT GUARD)
11A	1	SHAFT GUARD
9	1	IMPELLER NUT GASKET
8	1	O-RING (CASING/COVER)
6	1	IMPELLER NUT
5	1	STUB SHAFT
4	1	ADAPTER
3	1	IMPELLER
2	1	COVER
1	1	CASING

<sup>1</sup>NOT SHOWN

<sup>2</sup>WING NUT QUANTITY VARIES WITH PUMP MODEL

NOTE: Please be sure to always include pump type, size, and serial number with any reference to above numbers and names.

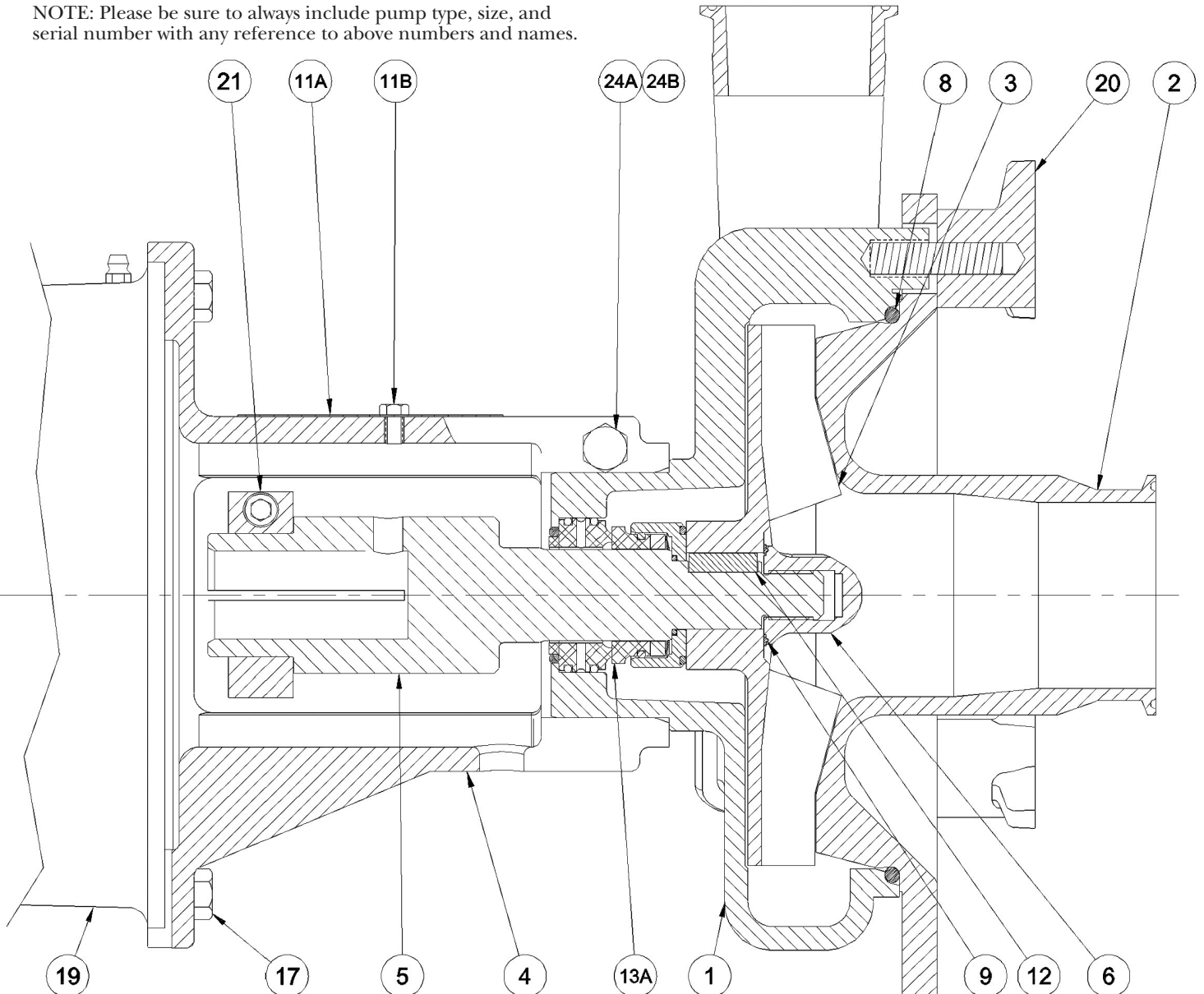

# Front Loading Mechanical Seal

DETAIL NO.	PART NAME
1	DOUBLE SEAL SPRING
2	DOUBLE ROTATING SEAL O-RING
3	DOUBLE ROTATING SEAL
4	DOUBLE STATIONARY SEAL O-RING
5	STATIONARY SEAL
6	SINGLE STATIONARY SEAL O-RING

DETAIL NO.	PART NAME
7	SINGLE ROTATING SEAL
8	SINGLE ROTATING SEAL O-RING
9	SINGLE SEAL SPRING
10	INNER SEAL DRIVER O-RING
11	SEAL DRIVER
12	OUTER SEAL DRIVER O-RING
13	IMPELLER NUT GASKET

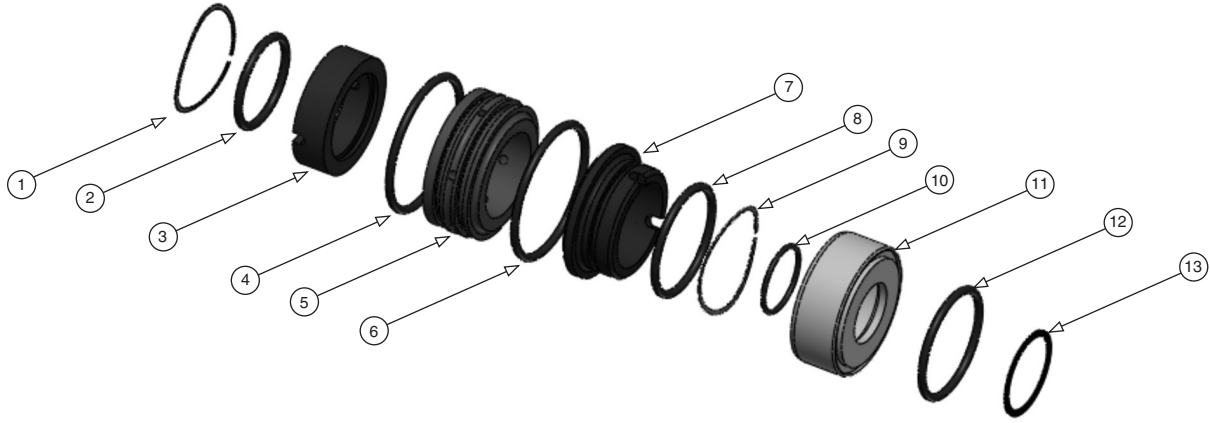

## Proper Torque For Bolts on LCF Series Pumps

Item	Torque ft-lbs	Pumps Included
Motor Bolts	20	140 Frame
	55	180 - 250 Frame
	70	280 Frame
	110	320 Frame
Adapter Tightening Bolt	55	Single flange
Volute Casing Nuts	50	Double flange
Shaft Collar Bolt(s)	15	- 180 Frame
	30	210 - 250 Frame
	40	280 - 320 Frame
Impeller Nut	40	- 320 Frame
	90	'see note below
Retaining ring Bolts	4.5	- 250 Frame
	10	280 + Frame

\*impeller nut to be 90 ft-lbs only for LCF-X050, X150, & X160 model pumps

## Proper Impeller Gaps For LCF Series Pumps

Pump Series	Impeller to Volute	Impeller to Cover
All R Models	0.020	0.020
V520	0.040"	0.020"
V530	0.040"	0.020"
V540	0.040"	0.020"
V550	0.040"	0.020"
X050	0.060"	0.080"
X150	0.060"	0.080"
X160	0.060"	0.080"

## Required Tools

1. Rubber Mallet
2. Ratchet
3. Torque Wrench
4. 9/16" socket - for 56-140 frame motor bolts
5. 3/4" socket - for 180-280 frame motor bolts
6. 15/16" socket - for impeller nut
7. 3/8" diameter steel rod - to hold stub shaft
8. Two - 3/4" wrenches (single flange design) - adapter tightening bolt  
One - 3/4" wrench (double flange design) - adapter bolts
9. Flat blade screwdriver (single flange design) - for widening adapter
10. Food grade lubricant
11. 3/16" Allen wrench - shaft collar bolt 56 - 180 frames  
1/4" Allen wrench - shaft collar bolt 210-250 frames  
5/16" Allen wrench - shaft collar bolts 280-360 frames
12. Impeller puller / pinch bars (may be necessary)
13. Feeler gauges (see Impeller Gap chart for sizes)

## Specifications

### Specifications

Maximum inlet pressure.....	150 psig
Operating temperature range.....	-40 F to 400 F
Product Contact Surface Finish.....	32 in Ra (standard) 15 in Ra electropolish optional

### Materials of Construction

Casing.....	316L Stainless Steel
Cover.....	316L Stainless Steel
Impeller.....	316L Stainless Steel
Stub Shaft.....	316L Stainless Steel
Adapter.....	304 Stainless Steel
Seal Driver.....	316L Stainless Steel
Single Rotating Seal.....	Silicon Carbide (standard) Chrome Oxide coated 316L Steel optional
Stationary Seal.....	Carbon Standard Silicon Carbide optional
Double Rotating Seal (if installed).....	Ceramic
Recommended Seal Flush Flow.....	1-2 GPH
Recommended Seal Flush Pressure.....	5 PSI Maximum
Gaskets/O-rings.....	Viton (standard) EPDM optional
Cover O-ring.....	Buna (standard) EPDM, Viton optional
Motor.....	NEMA TEFC C-face Painted Rolled Steel or Painted Cast Iron (standard) 3 Phase, 60 Hz, 208-230/460 VAC, 1750/3500 RPM Stainless Steel optional

## COMMON TROUBLES AND THEIR CAUSES

It is to the user's advantage to be familiar with a systematic procedure to determine reasons and causes for unsatisfactory pump operation. The following list of troubles and causes is intended to assist users in determining the cause of any pumping trouble. Faulty installations can then be corrected and a clear description given the manufacturer if assistance is required. Human judgment should not be relied on to measure operating conditions. Use proper instruments to measure values of pressure, suction lift, speeds, temperature rise of motors, etc. When motor speeds are incorrect, check connections and measure voltage at motor terminals.

### 1. No liquid delivered

- a. Pump and suction line not completely primed
- b. Speed too low
- c. Required discharge too high
- d. Suction lift too high
- e. Impeller, piping, or fittings completely plugged up
- f. Wrong direction of rotation

### 2. Not sufficient capacity

- a. Air leaks in suction pipe or shaft seal
- b. Speed too low
- c. Required discharge head too high
- d. Suction lift too high or insufficient NPSH available
- e. Impeller, piping, or fittings partially plugged
- f. Insufficient positive suction head for hot water or other volatile liquids
- g. Liquid viscosity too high
- h. Mechanical problems - impeller damaged, shaft seal defective
- i. Wrong direction of rotation
- j. Suction pipe entrance too close to surface of liquid
- k. Air pockets in pipe high points

### 3. Not sufficient pressure

- a. Speed too low
- b. Mechanical problems - impeller damaged, shaft seal defective
- c. Small impeller diameter
- d. Air or gas in liquid
- e. Wrong direction of rotation
- f. Air pockets in pipe high points

### 4. Pump operates for a while, then quits

- a. Leaky suction line
- b. Air leaking in through shaft seal
- c. Suction lift too high or insufficient NPSH available
- d. Air or gas in liquid
- e. Suction piping and fitting not completely freed of air during priming
- f. Air pockets in pipe high points

### 5. Pump takes too much power

- a. Speed too high
- b. Pumping too much water because required head is lower than anticipated.
- c. Viscosity and/or specific gravity is higher than specified
- d. Mechanical problems - binding inside seal from distortion due to piping strains, shaft bent, impeller rubbing casing
- e. Wrong direction of rotation

# Ampco Pumps Company

2045 West Mill Road  
Milwaukee, Wisconsin 53209  
(414) 643-1852 Telephone (414) 643-4452 Fax  
[www.ampcopumps.com](http://www.ampcopumps.com)